



ARRIFLEX D-21/D-21 HD

INSTRUCTION MANUAL

As of: January 2009

COPYRIGHT © 2009 ARNOLD & RICHTER CINE TECHNIK GMBH & CO BETRIEBS KG. ALL RIGHTS RESERVED.

NO PART OF THIS DOCUMENT MAY BE USED FOR DISTRIBUTION, REPRODUCTION, TRANSMISSION, TRANSCRIPTION, STORAGE IN A DATA RETRIEVAL SYSTEM, OR TRANSLATED INTO ANY LANGUAGE IN ANY FORM BY ANY MEANS WITHOUT THE PRIOR WRITTEN CONSENT OF ARRI.

IF YOU ARE DOWNLOADING FILES FROM OUR WEB PAGES FOR YOUR PERSONAL USE, MAKE SURE TO CHECK FOR UPDATED VERSIONS. ARRI CANNOT TAKE ANY LIABILITY WHATSOEVER FOR DOWNLOADED FILES, AS TECHNICAL DATA ARE SUBJECT TO CHANGE WITHOUT NOTICE.

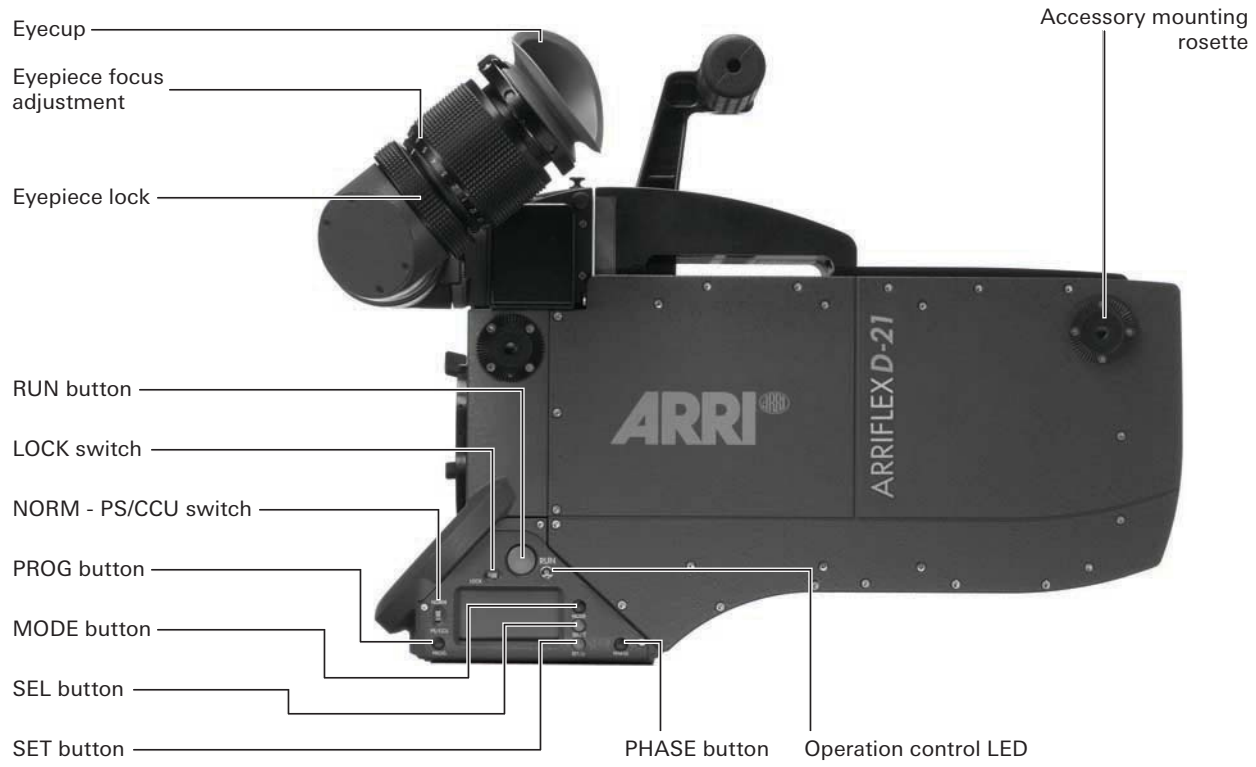

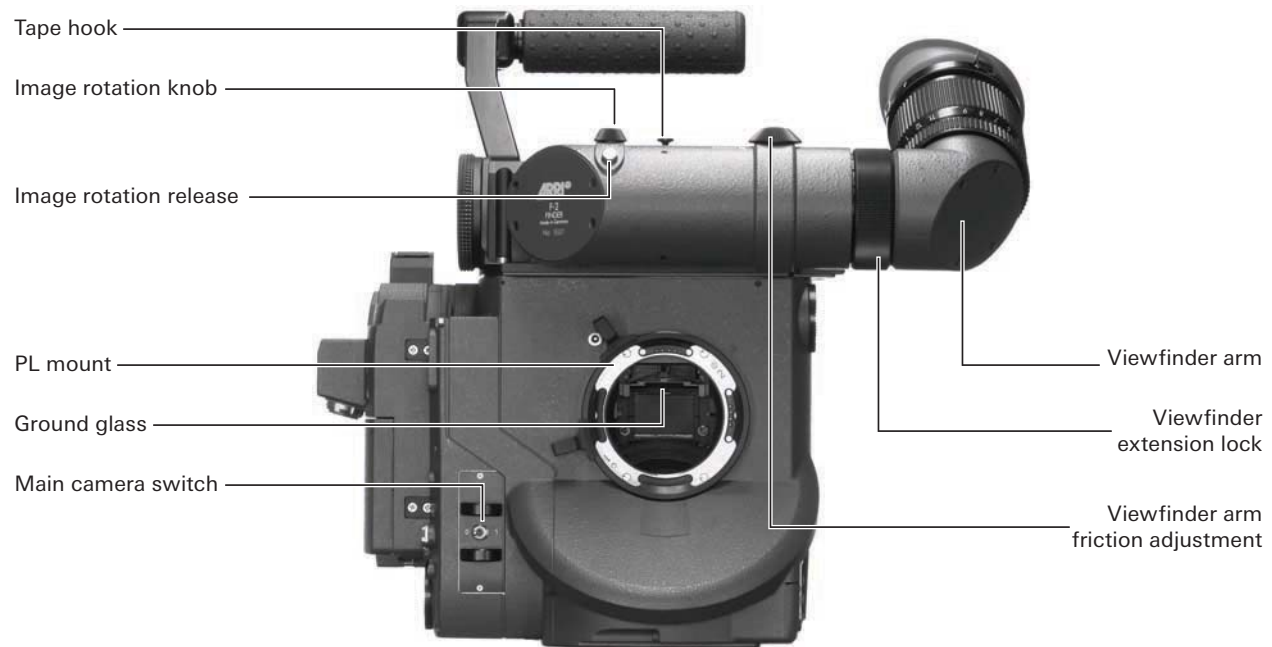

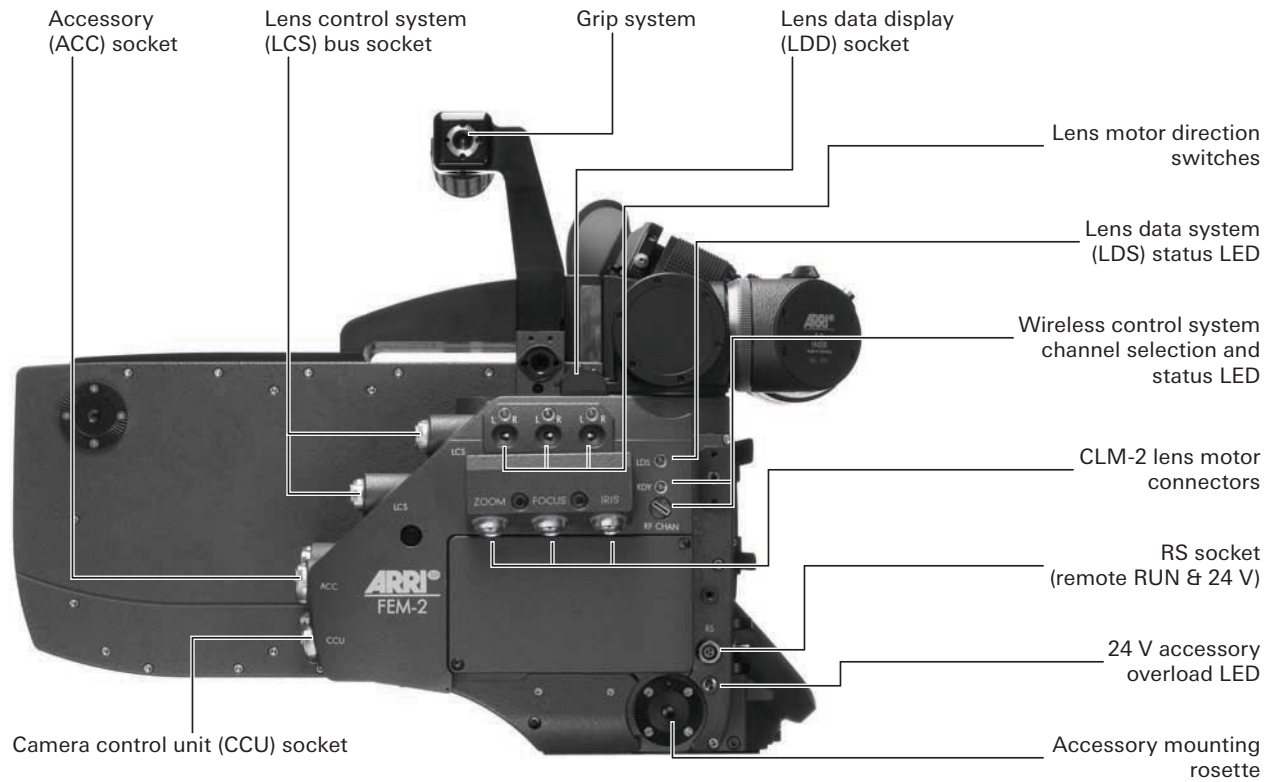

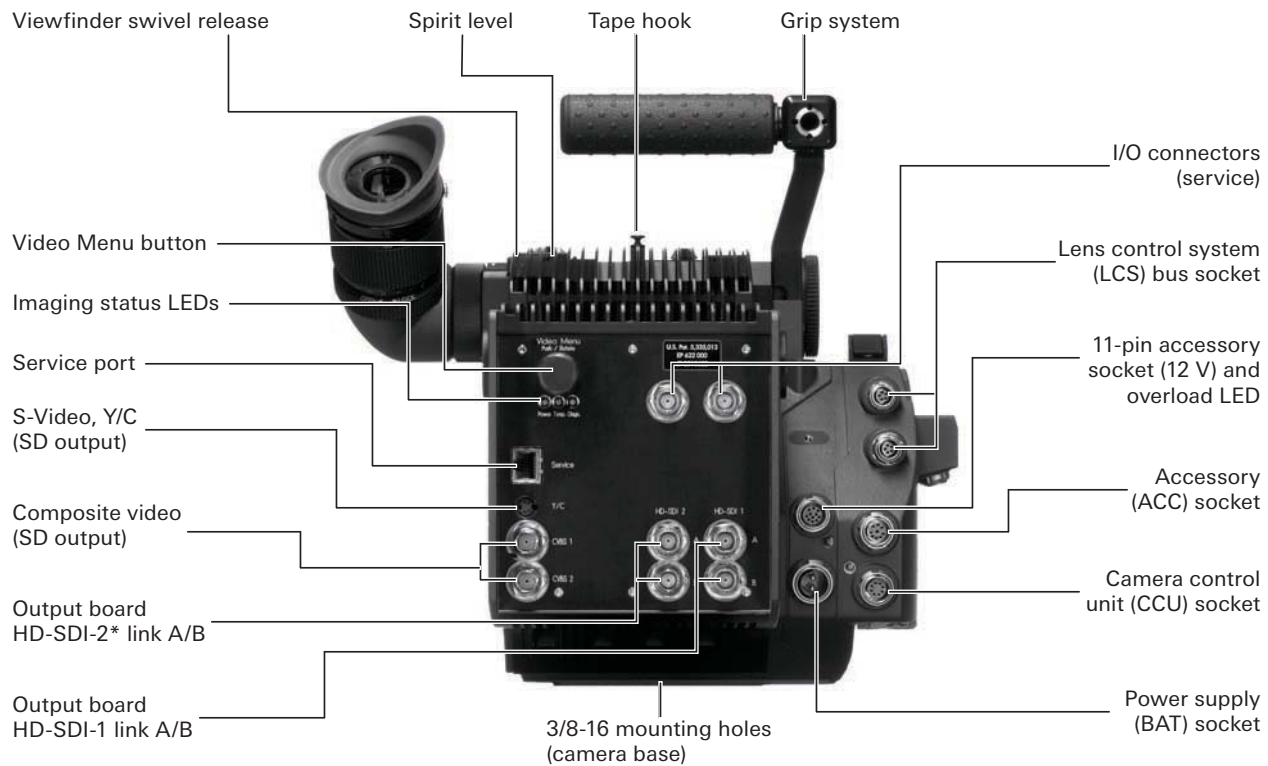

1. Contents

- 1. Safety Instructions and Legal Disclaimer 12**
 - 1.1. Safety Instructions 12
 - Explanation of Warning Signs and Indications..... 12
 - General Safety Instructions 12
 - Specific Safety Instructions..... 13
 - 1.2. Disclaimer 14
- 2. General Description 16**
 - Product Identification 16
 - Scope..... 17
- 3. Power Supply 18**
 - 3.1. Mains Unit NG 12/26 R 18
 - 3.2. Battery VCLX/2 19
 - 3.3. Charger for VCLX/2..... 19
 - 3.4. Main Camera Switch..... 20
 - 3.5. Accessory Power Supply 21
 - 12 V Accessories 21
 - 24V Accessories 22
 - Overload Display..... 22
- 4. Installation of the Camera 23**
 - 4.1. Minimum equipment needed for operation:..... 23
 - 4.2. Packing, Storage and Transport..... 23
 - Condensation..... 23
 - 4.3. Tripod and Remote Heads 24
 - 4.4. Horizontal Levelling..... 25

4.5.	Bridge Plate Set BP-8, BP-9	25
	Attaching the Bridge Plate to the Camera	26
	Putting the Camera on the Tripod	26
	Removing the Camera from the Tripod	26
4.6.	Lens Support.....	27
4.7.	Grip System	28
	Additional Hand Grips.....	28
	Removing the Grip System.....	28
5.	Optics.....	29
5.1.	Lenses.....	29
	Lens Mount.....	29
	Changing Lenses	30
5.2.	Viewfinder System.....	31
	Eyepiece.....	32
	Viewfinder Arm.....	33
	Image Orientation	34
	Removing the Viewfinder System	35
	Universal Finder Arm.....	36
5.3.	Ground Glasses.....	37
	Exchanging the Ground Glass	37
5.4.	ARRIGLOW	38
	Exchanging the ARRIGLOW Mask	38
6.	Camera Output Configuration	40
6.1.	Output Interfaces.....	40
6.2.	Video Menu.....	40
	Using the Video Menu	41

Status Indications	41
6.3. Setting Operational Parameters.....	42
User Mode	42
White Balance.....	44
Standard Frame Rate	46
Output Board (Advanced Mode).....	48
HD-SDI Mode	50
Overview of Available Output Formats.....	51
Output Range (Advanced Mode).....	52
Color Matrix (Advanced Mode)	53
Suitable Combinations of Contrast Characteristics, White Balance and Color Matrix	54
Contrast Characteristics	54
SD Mode	59
Diagnostics	61
6.4. OSD Tools	64
7. Signal Connections	65
7.1. Signal Wiring Instructions	65
HD422 Setup (Standard Mode)	66
HD422 High Speed Setup (Standard Mode).....	67
HD444 Setup (Standard Mode)	68
Mscope HD422 Setup (Standard Mode)	69
Data Mode/ARRIRAW Setup (Advanced Mode).....	70
8. Camera Operation	71
8.1. Running and Stopping the Camera.....	71
8.2. Camera Display Modes.....	72
Overview of Display Modes.....	73

	Overview of Display Symbols.....	74
	Shutter Angle Display (Mode 1).....	75
	Locking Camera Controls.....	75
8.3.	Standard and Programmed Frame Rates.....	76
	General Procedure for Changing Frame Rates.....	76
	Setting a Programmed Frame Rate (Mode 2).....	77
8.4.	Frame Counter and Battery Information.....	80
	Switching between Display of Frame Counter and Mirror Shutter Angle (Mode 1).....	81
	Setting the Frame Counter Configuration (Mode 3).....	81
	Displaying the Power Supply Voltage (Mode 3).....	82
8.5.	Mirror Shutter Angle and Warning Signal.....	83
	Enabling/Disabling the Asynchronous Running Warning Signal (Mode 4).....	83
	Enabling/Disabling the Mirror Shutter (Mode 4).....	84
	Setting the Mirror Shutter Angle (Mode 5).....	85
9.	Recording.....	86
9.1.	Recording Format Setup.....	86
9.2.	Starting and Stopping the Recording.....	86
	Recording devices with variable frame rate (VariFrame) support:.....	87
	Recording devices without variable frame rate (VariFrame) support:.....	87
10.	Functional Expansion Module FEM-2.....	88
10.1.	Lens Data System.....	89
10.2.	Wireless System.....	90
	Installing the URM-3 radio receiver.....	90
	Using the Wireless System.....	91
10.3.	Remote Lens Control.....	93
	CLM-2 Status Indications.....	93

10.4.	Camera Remote Control	94
10.5.	Compatibility.....	95
	ARRIFLEX D-21 FEM-2 Compatibility List.....	95
	Incompatible Accessories.....	96
10.6.	Replacing the FEM-2.....	96
	Removing the FEM-2	97
	Attaching the FEM-2.....	97
11.	Accessories	98
11.1.	External Synchronization Unit ESU-1	98
11.2.	Flash Mag Mounting Adapter FMA-1	99
11.3.	Heated Eyecup (HE-4/HE-5).....	100
11.4.	Isolating Power Adapter IPA-1	101
11.5.	Low Mode Support.....	102
11.6.	Remote Run Switch (RS-4)	104
11.7.	RS-Socket Distributor (24 V Plug-on module)	105
11.8.	Shoulder Set S-5.....	106
11.9.	Fiber Link Unit FLU-1	107
	Fiber Link Remote FLR-1	108
11.10.	Wireless Remote Control WRC-2	110
11.11.	Work Light	111
11.12.	General Note	111
12.	Camera Care	112
12.1.	General Information	112
12.2.	Imager Check.....	112
	Imager Surface	112
	Condensation.....	115

Pixel Failure.....	115
12.3. Cleaning the Field Lens.....	117
Notes:.....	118
13. Technical Data - ARRIFLEX D-21 & D-21 HD.....	119
13.1. Technical Data - ARRIFLEX D-21	121
13.2. Technical Data - ARRIFLEX D-21 HD	122
14. Appendix.....	123
14.1. Troubleshooting	123
14.2. Glossary	129
Clipping.....	129
Color Signals and Chroma (Sub-)Sampling	129
Data Mode	131
Dead/Defective Pixels.....	133
HD Mode	133
Mscope™	134
Pixel Failure.....	135
Scanning Methods (p, i, PsF).....	135
Notes.....	138
15. Index	139
16. ARRI Group Addresses.....	147

2. Safety Instructions and Legal Disclaimer

2.1. Safety Instructions



Always follow these instructions to ensure against injury to yourself and damage to the system or other objects.



This safety information is in addition to the product specific operating instructions in general and must be strictly observed for safety reasons.

Explanation of Warning Signs and Indications



Possible risk of injury or damage to equipment.



This Symbol indicates the risk of electric shock or fire danger that could result in injury or equipment damage.

Note: indicates further information or information from other instruction manuals.

⇨ **image** indicates objects, which are shown in an illustration or picture.

General Safety Instructions



Read and understand all safety and operating instructions before you operate or install the system!



Retain all safety and operating instructions for future reference!



Heed all warnings on the system and in the safety and operating instructions before you operate or install the system! Follow all installations and operating instructions!



Do not use accessories or attachments that are not recommended by ARRI, as they may cause hazards and invalidate the warranty!



Do not attempt to repair any part of the system! Repairs must only be carried out by authorized ARRI Service Centers.









Do not remove any safety measures of the system!









Do not operate the system in areas with humidity above operating levels or expose it to water or moisture!



Do not place the system on an unstable trolley/ hand truck, stand, tripod, bracket or table! The system may fall, causing serious personal injury and damage to the system or other objects.

-  *Operate the system using only the type of power source indicated in the manual! Unplug the power cable by gripping the power plug, not the cable!*
-  *Never insert objects of any kind into any part of the system through openings, as the objects may touch dangerous voltage points or short out parts! This could cause fire or electrical shock.*
-  *Unplug the system from the power outlet before opening any part of the system or before making any changes to the system, especially the attaching or removing of cables!*
-  *Do not use solvents to clean!*
-  *Do not remove any screws that have been secured with paint!*
-  *Attention! Danger of injury!
Never place your hand in the lens mount receptacle or the inside of the camera while it is running!*

Specific Safety Instructions

-  *Never run the camera without a lens or a protective cap in the lens mount receptacle!*
-  *Remove the all cable connections before transport or servicing!*
-  *Changing camera lenses should be done in a dry and dust-free environment. If this is not possible, take extra care that no dust enters the camera while the lens is off!*
-  *Before removing the lens, always make sure to stop the mirror shutter! This not only prevents damage to the shutter in case a wrong lens is inserted (e.g. 16 format lens). The shutter in "finder-open" position acts also as a protective cover to the sensor.*
-  *When no lens is attached to the camera, use the protective cap to avoid sensor contamination!*
-  *After changing lenses, always perform a dust check to make sure no dust has settled on the sensor cover glass!*
-  *Clean optical lens surfaces only with a lens brush or a clean lens cloth! In cases of solid dirt, moisten a lens cloth with pure alcohol!
Discard contaminated lens cloth after use!
Do not use it to clean lens!*



*If the sensor cover glass has been contaminated **NEVER USE CANS WITH COMPRESSED AIR OR GAS TO BLOW OFF THE DUST!** This can severely damage both the mirror shutter and the sensor cover glass.*



Loose dust can be blown off with a blower bulb or a lens brush.



If the sensor cover glass has been contaminated by solid dirt or grease, special optical cleaning kits should be used very carefully for removal. If the contamination cannot be removed, the camera should be taken to an ARRI Service Center for cleaning.



Never clean a lens brush with your fingers!



NEVER USE METHANOL OR ACETONE TO CLEAN THE SENSOR COVER GLASS!



NEVER REMOVE THE SENSOR COVER GLASS!



Do not point the camera into direct sunlight or very bright light sources! This may lead to severe injury of your eyes and/or permanent damage to the camera sensor.

Any violation of these safety instructions or non-observance of personal care could cause serious injuries (including death) and damage to the system or other objects.

2.2. Disclaimer

Before using the products described in this manual be sure to read and understand all respective instructions.

The ARRIFLEX D-21/D-21 HD is only available for commercial customers. The customer grants by utilization, that the ARRIFLEX D-21/D-21 HD or other components of the system are deployed for commercial use. Otherwise the customer has the obligation to contact ARRI preceding the utilization.

While ARRI endeavors to enhance the quality, reliability and safety of their products, customers agree and acknowledge that the possibility of defects thereof cannot be eliminated entirely. To minimize risk of damage to property or injury (including death) to persons arising from defects in the products, customers must incorporate sufficient safety measures in their work with the system and have to heed the stated canonic use.

ARRI or its subsidiaries do not assume any responsibility for incurred losses due to improper handling or configuration of the camera or other system components, due to sensor contamination, occurrence of dead or defective pixels, defective signal connections or incompatibilities with third party recording devices.

No part of this document may be copied or reproduced in any form or by any means without prior written consent of ARRI. ARRI assumes no responsibility for any errors that may appear in this document. The information is subject to change without notice.

For product specification changes since this manual was published, refer to the latest publications of ARRI data sheets or data books, etc., for the most up-to-date specifications. Not all products and/or types are available in every country. Please check with an ARRI sales representative for availability and additional information.

Neither ARRI nor its subsidiaries assume any liability for infringement of patents, copyrights or other intellectual property rights of third parties by or arising from the use of ARRI products or any other liability arising from the use of such products. No license, express, implied or otherwise, is granted under any patents, copyrights or other intellectual property right of ARRI or others.

ARRI or its subsidiaries expressly exclude any liability, warranty, demand or other obligation for any claim, representation, or cause, or action, or whatsoever, express or implied, whether in contract or tort, including negligence, or incorporated in terms and conditions, whether by statute, law or otherwise. In no event shall ARRI or its subsidiaries be liable for or have a remedy for recovery of any special, direct, indirect, incidental, or consequential damages, including, but not limited to lost profits, lost savings, lost revenues

or economic loss of any kind or for any claim by third party, downtime, good-will, damage to or replacement of equipment or property, any cost or recovering of any material or goods associated with the assembly or use of our products, or any other damages or injury of the persons and so on or under any other legal theory.

In the case one or all of the foregoing clauses are not allowed by applicable law, the fullest extent permissible clauses by applicable law are validated.

ARRI is a registered trademark of
Arnold & Richter Cine Technik GmbH & Co Betriebs KG.

Note: This product and the accessories recommended by the manufacturer fulfill the specifications of the EU-Guideline 89/336/EWG.

3. General Description

The ARRIFLEX D-21 and D-21 HD combine leading edge digital technology with film camera features that have been refined over ARRI's 90-year history. They allow directors and cinematographers to shoot in the same way as they would with 35 mm film, while taking advantage of the immediacy and economy of digital acquisition.

As the top of the line digital cameras from ARRI, the market leader in professional imaging, they are equipped with a number of unique features:

An optical viewfinder, the Mscope™ anamorphic output, a 4:3 format sensor, simple operation and an unequalled film-like image quality. In addition, the D-21 is the only camera capable of simultaneously outputting raw data and HD.

The bright optical viewfinder has zero delay, works without power and shows an image area outside the primary image. Through ARRI Imaging Technology (AIT), both cameras produces brilliant images with a cinematic look and feel, a high dynamic range, high contrast and the most film-like motion and color reproduction of any digital motion picture camera.

The cameras' single, Super 35-sized CMOS sensor exhibits the same cinematic depth of field as 35 mm film. The industry standard PL lens mount accepts the same vast variety of prime, zoom and specialty film lenses used on 35 mm film cameras. Since both

cameras are the only digital high-end cameras with a 4:3 aspect ratio sensor, they easily accommodate all image formats, including anamorphic 2.40:1. The anamorphic image can be recorded in the new and innovative Mscope™ mode, utilizing a standard HD workflow, or, on the D-21, also in Data Mode.

Further film style features include variable frame rates from 1 to 60 fps (D-21)/1-30 fps (D-21 HD), exposure compensated speed ramps, compatibility with ARRI film style accessories, simple to use controls and the robust construction and ergonomic design for which ARRI cameras are famous.

The ARRIRAW format enables the D-21 to output raw uncompressed data. Alternatively, both D-21 and D-21 HD can output an uncompressed HD signal that works perfectly in the established HD infrastructure. With such flexibility, both ARRIFLEX D-21 and D-21 HD easily adapt to a variety of production requirements and budgets.

Product Identification

When ordering parts or accessories, or if any questions should arise, please advise the model type and serial number of the product in question.

Scope

This instruction manual applies to the following ARRIFLEX D-21/D-21 HD software and firmware versions:

Camera software packet 1.16 - CRC 2be9f
Color management version R2.20
E-cover software version 2.03
E-cover firmware version 1.09

Different software versions can result in different behavior.

Note: Unless noted otherwise (corresponding sections will be marked with a footnote), all instructions and descriptions stated in this manual apply to both, the ARRIFLEX D-21 and the ARRIFLEX D-21 HD.

4. Power Supply

Available ARRI power supply solutions:

- VCLX/2 battery (280 Wh)
- VCLX/2 battery charger
- NG 12/26 R mains unit

 *Do not open the batteries!
Charge batteries only with original chargers!*

 *Do not bypass the fuse or temperature switch!*

 *Do not heat batteries!*

 *Do not short-circuit batteries!*

The acceptable supply voltage for the ARRIFLEX D-21 ranges from 20.5 to 36 V DC.

4.1. Mains Unit NG 12/26 R

Use of the mains unit is recommended for shooting in the studio and when using electronic accessories with high power consumption.

- First check that the correct mains voltage is set on the mains unit.
- Ensure that the camera power is turned off.



- Set the voltage switch on the mains unit to 26 V.
- Plug the battery cable KC-20S or the spiral battery cable KC-29S into the power supply socket on the camera and into the 26 V-socket on the mains unit.

Note: The NG 12/24 R was the original design that provided 12 & 24 volts output – it was superseded by the NG 12/26 R, which outputs 12 & 26 volts. The NG 12/24 R can easily be upgraded to NG 12/26 R specification at an ARRI service Center.

4.2. Battery VCLX/2

The battery VCLX/2 has a capacity of 280 watt hours.

- Ensure that the main switch on the camera is off.
- Plug the battery cable KC-20S or the spiral battery cable KC-29S into the power supply socket on the camera and into the battery-socket.

Note: If the battery voltage is not sufficient for camera operation, the "bat" symbol will show in the camera display. Once the "bat" symbol starts flashing, the signal output is about to terminate.



4.3. Charger for VCLX/2

Charge the VCLX/2 battery only with this charger.

- First check whether the correct mains voltage is set on the charger.
- Connect the charger to the mains supply.
- Plug the charger cable into the battery socket.

LED	Indication
Red	Hold
Flashing red	Charging
Green	Ready to use

Indication of the LEDs

4.4. Main Camera Switch

The main camera switch is located on the front side of the camera. To connect the camera to a power supply:

- First switch on the mains unit (if used).
- Connect the camera to the mains unit or to the battery.
- Set the main camera switch ⇄ **image** to the "1" position to turn the camera on.
- Setting the main power switch to the "0" position cuts off the power supply.

The camera has to boot before it enters standby mode.

During booting, the operation control LED and imaging status LEDs on the rear of the camera ⇄ **image** light up red and the camera display shows the busy indicator. When the camera is ready for operation, the operation control LED turns off and the imaging status LEDs light up green.

Do not operate the camera before all three imaging status LEDs light up green! Using any of the camera's buttons before it is ready for operation may cause faulty behavior.

Note: When the camera is turned on, the mirror shutter stays in the position it was set to before the camera was turned off. If no image can be seen through the viewfinder, briefly press the PHASE button twice to rotate the mirror into viewing position.

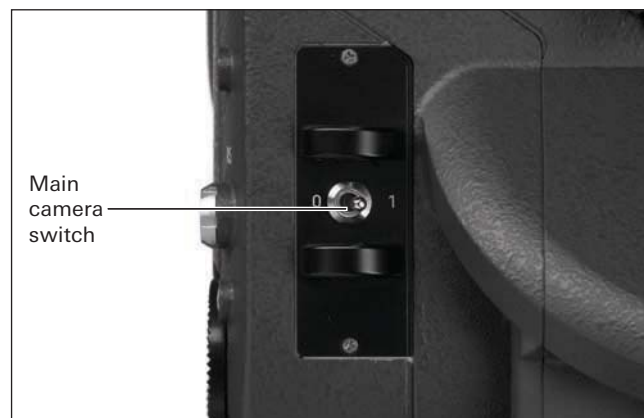

4.5. Accessory Power Supply

12 V Accessories

12 V accessories can be attached to the 11-pin accessory socket **image**, which provides stabilized 12 V DC with 3 A maximum load.



The 11-pin accessory socket power output is not electrically isolated from camera ground. Ground loops may cause damage to camera or connected 12 V equipment.

Note: When the camera is powered from mains and a 12 V onboard monitor is powered from the camera, running a video connection between this monitor and another device that is also powered from mains is likely to cause a ground loop. The Isolating Power Adaptor IPA-1 (see chapter 12: Accessories) provides a 12 V isolated output from the camera to avoid ground loops.

Note: The 11-pin accessory socket can only be used as an output socket. Accessories that feed signals into the camera will not function at this socket.

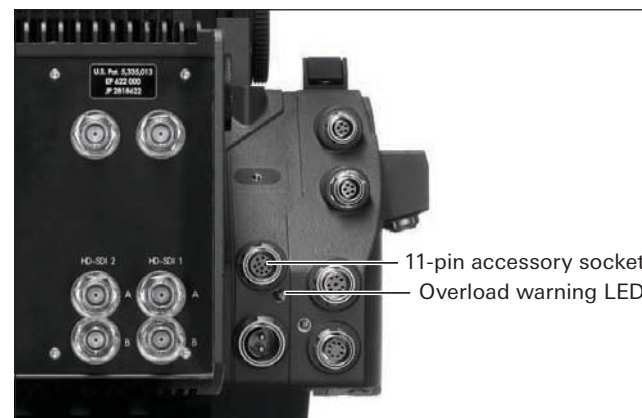

24V Accessories

24V accessories are normally attached to the RS-socket ↻**image**. At 24V, the available continuous current is 3A maximum, and peak load is 5A.



The RS-socket supplies the same voltage as the camera power supply. Voltages over 32V will be limited to 32V. In this case, the maximum allowable continuous current is 2A. Ensure that the accessories to be used are suited for the available voltage!

Overload Display

If the current drawn at the accessory sockets exceeds the allowable maximum, a self-resetting safety circuit interrupts the power supply and a red warning LED lights up ↻**image**. If this happens, turn the camera off, unplug all accessories from the camera, wait for one minute and turn the camera back on.

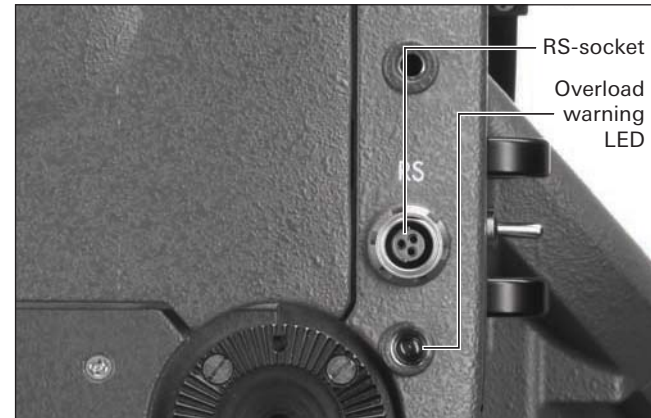

5. Installation of the Camera

5.1. Minimum equipment needed for operation:

- ARRIFLEX D-21/D-21 HD
- 35 format lens with PL-Mount
- Power supply NG 12/26 R or battery VCLX/2 and power supply cable KC-20S or KC-29S
- Video monitor with composite video IN (video menu operation) and optionally HD-SDI IN (signal monitoring)
- HD or Data recording unit including power supply and power cables
- HD control monitor attached to the recording device including power supply and cables
- 75 Ohm BNC cable connection to video monitor
- 75 Ohm HD compliant BNC cables for HD signal connection to recording unit and control monitor

Note: Details on signal connections, camera configuration and -operation are provided in the following chapters.

5.2. Packing, Storage and Transport



In order to prevent damage to the mirror shutter and the sensor, a protective cap must be on the lens mount receptacle whenever no lens is attached (e.g. during transport or shooting breaks).



When the ARRIFLEX D-21 is transported or stored, cables have to be unplugged from the camera.

Note: It is recommend that when shipping the ARRIFLEX D-21 the ground glass is removed from the camera and placed separately in the appropriate box.

Condensation

When moving the camera from a cool to a warm location or when the camera is used in a damp climate, condensation may form inside the lens compartment, on the sensor cover glass and on the electrical connections.



Operating the camera in this state may cause a failure or even permanent damage.

To reduce the risk of condensation:

- Attach the included air-drying cartridge to the PL-Mount of the camera when the camera is stored in an environment that is cooler than the location the camera will be used at.
- In ambient temperatures above 30 °C/86 °F and/ or humidity above 60%, always attach the drying cartridge to the PL-Mount of the camera, whenever the camera is not used. This not only applies to storage, but also to shooting breaks and situations when the camera remains without a lens attached for an extended time.



When the ARRIFLEX D-21 is transported or stored inside a transport case, the air-drying cartridge has to be removed.

5.3. Tripod and Remote Heads

Tripod heads and remote heads used with the ARRIFLEX D-21 have to provide enough load capacity to support the camera and attached accessories. The table to the right shows the camera weight for different components.

Note: Check for the payload of remote heads and cranes.



In applications where the camera mount is subject to high forces (e.g. car- or helicopter mounts) the camera must be additionally secured with retaining cords. All fastening screws must be tightened firmly with an appropriate screwdriver (not with the commonly used coin!).

Camera Weight	lbs	kg
ARRIFLEX D-21 incl. finder, eyepiece, bridge plate set, handle	25.0	11.4
ARRIFLEX D-21 camera body	19.0	8.6
ARRIFLEX D-21 HD camera body	18.8	8.5
Function expansion module FEM-2	1.8	0.8
Viewfinder and eyepiece	5.0	2.2
BP-8 base plate top	1.0	0.4
Finder extension FE-3	2.0	0.9
Low mode support	2.0	0.8
Flash mag mounting adapter FMA-1	3.0	1.2

5.4. Horizontal Levelling

The ARRIFLEX D-21 is equipped with a spirit level to aid horizontal levelling of the camera ⇄image.



Please use caution when attaching accessories or a recording device to the camera or the support rods as the center of gravity may shift towards the front or back, which can tip over the camera.

5.5. Bridge Plate Set BP-8, BP-9

The bridge plates facilitate balancing of the camera on the tripod and mounting of accessories.

BP-8 is designed for 19 mm support rods.

BP-9 is designed for 15 mm support rods.

The bridge plate sets consist of the base plate, bridge plate, and a pair of 440 mm support rods. 19 mm support rods with lengths of 165, 185, 240, 340 and 440 mm or 15 mm diameter support rods with lengths 340 and 440 mm are available separately as options.

Note: The bridge plate has to be adjusted to Super 35 for use with the ARRIFLEX D-21. This ensures that the accessories are exactly adapted to the optical center of the Super 35 format. This also applies when anamorphic lenses are used (unlike with 35 mm cameras).

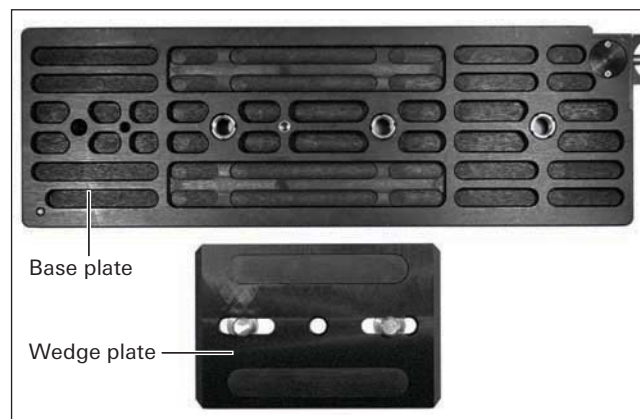

Attaching the Bridge Plate to the Camera

- Screw the wedge plate onto the base plate and lock them onto the tripod head.
- Engage the two cylindrical pins on the bridge plate with the corresponding holes in the camera base and fasten it to the 3/8-16 threaded holes in the camera base with the two slotted screws ⇨**image**.

Note: Fastening the screws too tightly may cause

Putting the Camera on the Tripod

- Slide camera with the bridge plate into the dovetail-guide of the base plate until the spring-loaded stop pin snaps back audibly. The camera's position can then be fixed with the clamping lever ⇨**image**.
- Slide the support rods into the guides and clamp.
- Equip the camera with the required accessories to determine the center of gravity. Loosen the clamping lever, and by sliding the camera on the base plate find the optimal balance position. Then retighten the clamping lever.

Removing the Camera from the Tripod

- Before removing the camera make sure that all cables are disconnected and that the eyepiece levelling rod is detached.
- Loosen the clamping lever, push in the stop pin and then pull the camera with the bridge plate from the base plate ⇨**image**.

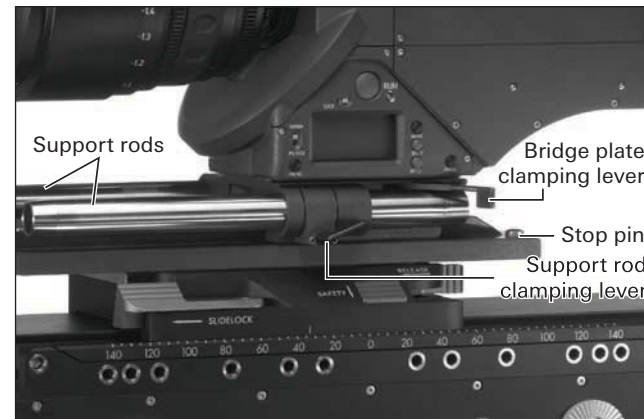
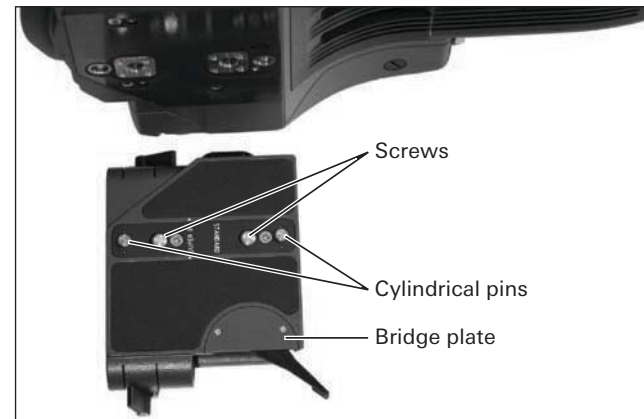

5.6. Lens Support

Heavy or long lenses require support to avoid overstressing the camera's lens mount. Supporting a lens is achieved by using either lens support LS-9 ↻**image** (for 19 mm support rods) or lens support LS-10 (for 15 mm support rods) in conjunction with a lens support ring attached to the lens in use. They meet and screw together at a standard height.

- Mount the LS-9 lens support onto the support rods from above and let it snap into place by applying slight pressure. The LS-10 is mounted by pushing it onto the support rods from the front.
- Fit the appropriate support ring ↻**image** loosely onto the lens. Do not tighten.
- Then slide the lens into the lens mount receptacle and lock. It is essential that you take the weight of the lens mount until the lens support column of the support ring can rest on the lens support.
- Move the LS-9/10 lens support so it is located under the support column of the lens support ring.
- Fix the lens support in position by tightening the knurled screw of the LS-9/10 ↻**image**.
- Complete the process by tightening the clamp screw ↻**image** on the support ring.

Note: Mounting the support ring on the relevant lens is usually carried out only once. The support ring can then remain in position on the lens.

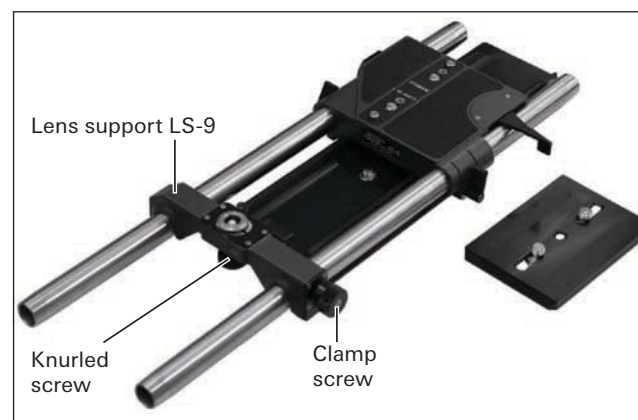

5.7. Grip System

The multipurpose grip system on the ARRIFLEX D-21 guarantees high stability through its fixed connection to the camera body and provides numerous possibilities for attaching accessories. Five 3/8" inner threads allow attachment in diverse positions ↻**image**.

Additional Hand Grips

Additional hand grips can be screwed onto the grip system in various positions as required. There are two types of hand grips.

Version without registering pins:

- Using a 5 mm Allen key, turn the 3/8" threaded bolt into the hand grip as far as it will go.
- Turn the hand grip to screw it into the grip system.
- Pull tight to enable the safety mechanism which prevents loosening.

Version with registering pins:

- Place the hand grip on the grip system so the registering pins are inserted into the provided holes.
- Using a 5 mm Allen key, tighten the hand grip to the grip system with the 3/8" threaded bolt.

Removing the Grip System

In order to minimize camera height, the entire grip system can be removed.

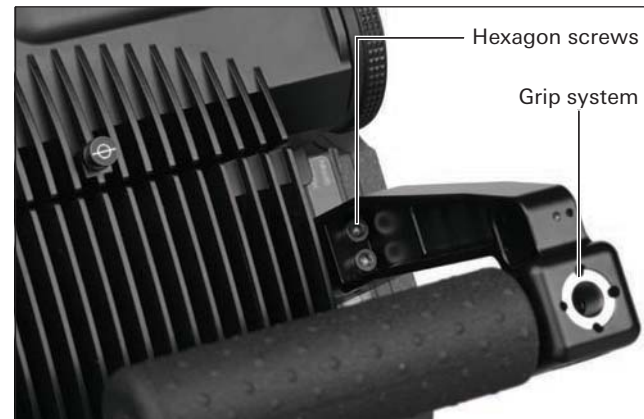

- Using a 3 mm Allen key, loosen both the hexagon screws ↻**image** in the strut and pull the grip system upwards.
- To attach the grip system, proceed in the reverse order.

Note: To provide an even sturdier hand grip system with additional attachment points for accessories, the camera can also be equipped with the low mode short set. See chapter 12: Accessories for more information.

6. Optics

6.1. Lenses

All 35 format lenses with a PL-mount can be used on the ARRIFLEX D-21. Lenses with a \varnothing 41 mm standard or bayonet mount cannot be used.



Heavy and long lenses, such as zoom lenses, must be supported at all times.

Note: Although the filters in front of the sensor are coated and polished using high-precision technologies, slight variations may cause a shaded structure in the output image depending on the aperture of the lens. Closing the iris beyond T11 therefore is not recommended.

Lens Mount

ARRIFLEX D-21 and D-21 HD are equipped with Lens Data System contacts  for direct communication with LDS lenses. The Lens Data System collects essential lens and camera information for display on a dedicated remote display and enables iris compensated speed ramps in conjunction with a Wireless Remote Control.

These features are also available for non-LDS lenses, where focus, iris and zoom information is calibrated through the lens motor (CLM-2) position, which is then stored into accessories, such as the Lens Data Archive (LDA) or the Wireless Remote Control (WRC-2).

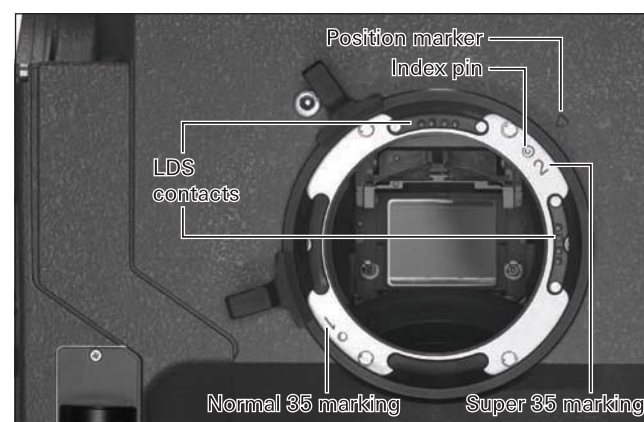

Lens Mount Position

The lens mount should always remain in Super 35 position (2) , although it is possible to rotate the lens mount to Normal 35 configuration (1). Unlike with 35 mm cameras, this also applies when anamorphic lenses are used.

Changing Lenses

Changing camera lenses should be done in a dry and dust-free environment.



Before changing or removing a lens, always make sure to stop the mirror shutter. This not only prevents damage to the shutter when a wrong lens (e.g. 16 format lens) is inserted by mistake. The shutter in "finder-open" position acts also as a protective cover to the sensor (cover glass).

- Take care that no dust can enter the lens compartment while no lens is attached.
- Remove the mounted lens or protective cap from the lens mount receptacle by turning the bayonet ring ↺ **image** counter-clockwise as far as it will go and then pulling out the lens or protective cap.



Never put your fingers into the lens mount receptacle.

- Push the lens to be used into the lens mount receptacle without catching it at the edges. One of the four slots on the lens mount must fit over the index pin ↷ **image**.
- Press the lens flat onto the lens mount receptacle and pull the bayonet ring clockwise to tighten.



Always perform a dust check after changing lenses to make sure no dust has settled on the sensor cover glass!

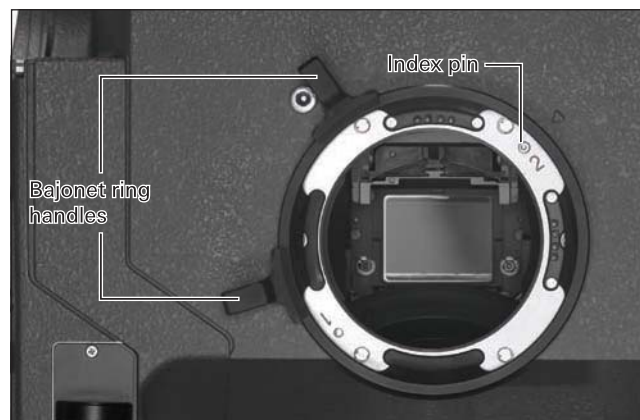

Note: When no lens is attached to the camera for an extended period of time, use the protective cap to avoid dust entering the lens compartment. See chapter 13: Camera Care for dust check instructions.

Note: The sophisticated design principle of the camera's optical module delivers outstanding images with cinematic look and feel, but also makes the imager sensitive to contamination. Dust particles that have settled on the sensor cover glass during a lens change may become visible as dark spots in the output image, similar to lint leaving marks on exposed film. The degree of this effect depends on the aperture of the lens.

6.2. Viewfinder System

The ARRIFLEX D-21 has an optical reflex viewfinder system with interchangeable ground glasses. The viewfinder is adjustable in two axes, laterally extendable for left eye operation and shows illuminated frame lines (ARRIGLOW).

The viewfinder image stays upright and correct left-to-right when the viewfinder is swivelled within the main axis ↔**image**. Warning signals (BAT, ASY) are reflected into the viewfinder.

Note: When the camera is turned on, the mirror shutter stays in the position it was set to before the camera was turned off. If no image can be seen through the viewfinder, briefly press the PHASE button twice to rotate the mirror into viewing position.



Eyepiece

The camera can be equipped with an 8x or 10x wide-angle eyepiece. The eyepiece can be extended with a medium (FE-5) or a long (FE-3) finder extender.

Note: When a finder extender is used, the viewfinder image has to be manually rotated by 180°. See 'Image Orientation' below.

Removing the Eyepiece

- Hold the eyepiece with one hand and with the other turn the knurled ring ↻ **image** in the "OPEN" direction until it unscrews from the eyepiece.
- Remove the eyepiece.

Attaching the Eyepiece

- With the knurled ring in "OPEN" position, place the eyepiece on the viewfinder.
- Turn the knurled ring towards the "LOCK" position.
- Check that the eyepiece is correctly seated.

Diopter Compensation

The diopter compensation is fitted with a scale of 1 to 12. Position "6" is normal focus.

- To adjust, turn the ring right/left until the ground glass markings are in focus.



Turning the Eyepiece

The eyepiece can be rotated by 360° around the viewfinder arm. The adjusted position is held by friction.

- To set the amount of friction, turn the friction knob ↻ **image** (next page) right/left until the desired friction has been reached.

Viewfinder Arm

Swiveling the Viewfinder Arm

The viewfinder arm can be swivelled approx. 270° left to right. On the left side of the camera the viewfinder arm locks into the horizontal position. The viewfinder arm friction can be altered if necessary by turning the Allen screw ⇄**image**.

- To adjust the viewfinder arm, release the locking mechanism by pressing the swivel release ⇄**image**.
- Turn the viewfinder arm to the desired position.

Extending the Viewfinder Arm

The viewfinder arm can be extended continuously by approx. 50 mm/2 inches.

- Turn the extension lock ⇄**image** towards the "LOOSE" position.
- Pull the viewfinder arm out to the desired length.
- Retighten the knurled ring.

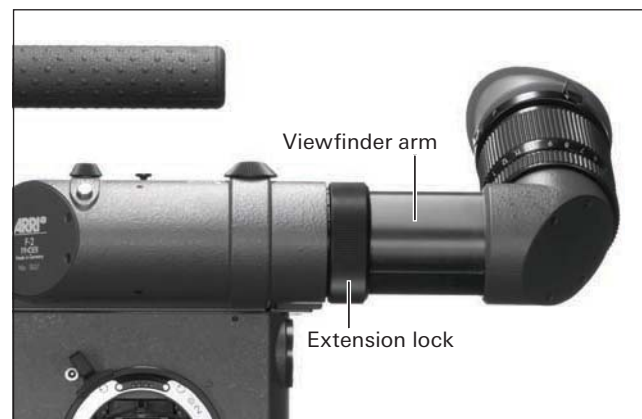
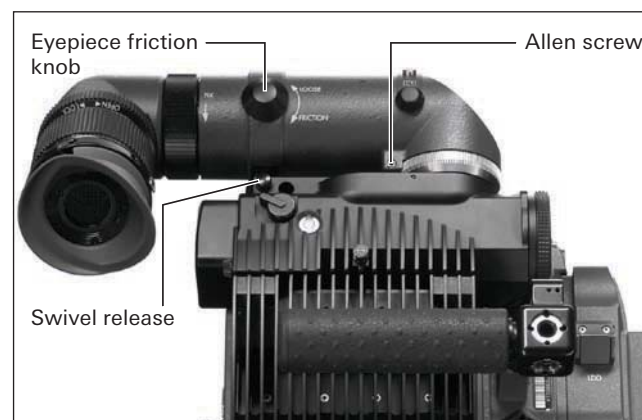

Image Orientation

The viewfinder system is fitted with an automatic image orientation mechanism. For certain situations the image position can also be adjusted manually, e.g. when using a viewfinder extension, which rotates the image by 180°.

Manually Adjusting Image Orientation

- Press and hold the manual rotation release ⇄**image**.
- Turn the manual rotation knob ⇄**image** until the viewfinder image is in the desired position.

Reactivating Image Orientation

- Turn the adjustment knob ⇄**image** until this locks in position. Do not press the locking key.

Note: The automatic image orientation mechanism locks in two positions 180° apart.

Pivoting the Contrast Filter

To achieve a temporary subjective reduction of viewfinder contrast, a contrast filter (ND 6) can be pivoted into the optical beam path by means of a lever ⇄**image**.

- The contrast filter is brought into the "ON" position by turning the lever.
- Releasing the lever switches the contrast filter back into the "OFF" position.

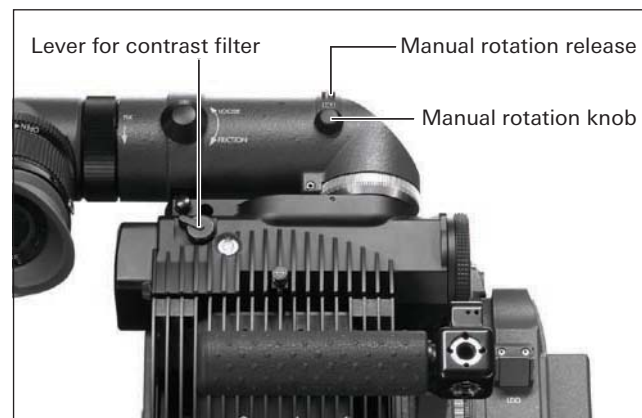

Removing the Viewfinder System

The entire viewfinder system can be removed for special applications. Before removing the viewfinder system, the viewfinder arm should be brought back to its normal position.

Note: The camera should be securely placed on a stable flat surface or fixed on a pivoting head to provide a secure working environment.

- Loosen the three fastening screws using a 3 mm Allen key ⇄**image**.
- Pull the viewfinder system up and off the camera.



Removing the viewfinder system exposes optical surfaces on both camera and viewfinder. Do not touch the cover glasses!



Never operate the camera with an open viewfinder interface!

If the camera shall be used without viewfinder system, the viewfinder interface has to be protected using the viewfinder cover plate ⇄**image** from the D-21 low mode support K2.70004.0 or low mode short set K2.70010.0:

- Place the viewfinder cover plate on the camera from above.
- Tighten the three fastening screws.
- Store the viewfinder system in a clean environment laying it upside down to avoid scratching the cover glass.

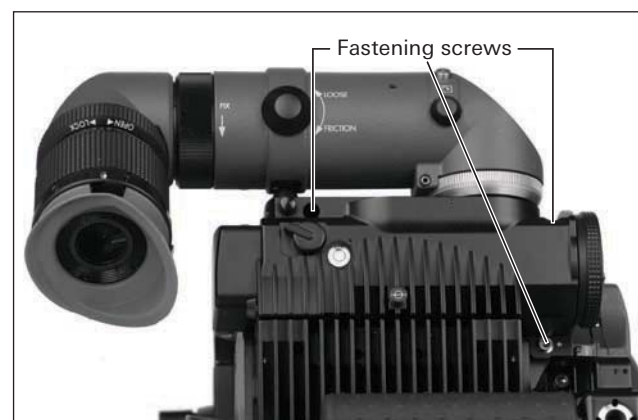

Attaching the Viewfinder System

- Place the viewfinder system on the camera from above.
- Tighten the three fastening screws.

Universal Finder Arm

When using anamorphic lenses, the D-21 can be equipped with an AVF-1 universal finder arm ↪**image**, which allows de-squeezed viewing of the ground glass image. This viewfinder arm can also be switched over to check the anamorphically squeezed image or for use with a spherical lens. The universal finder arm can be fitted in place of the standard viewfinder arm by a service center or in a rental house.

- To switch the viewfinder image to spherical or de-squeezed anamorphic viewing, turn the switching knob ↪**image**. The knob does not need to be unlocked.

All other functions are identical to those of the standard spherical finder arm.

Note: Anamorphic capture requires Mscope or data mode/ARRIRAW^[1] output. See chapter 7: Camera Configuration.



[1] Data Mode output not available on the D-21 HD.

6.3. Ground Glasses

The sensor aperture of the ARRIFLEX D-21 is slightly different from the camera aperture of the ANSI and DIN Super 35 format. Therefore, Super 35 ground glasses for ARRIFLEX 235/435/535 do not provide exact frame markings in the D-21 viewfinder image. For exact framing, only use ground glasses that are listed for digital ARRIFLEX cameras. For a list of available formats, please check the D-21 price list.

Exchanging the Ground Glass

- If the mirror shutter is not positioned in front of the sensor, briefly press the PHASE-button in standby so the shutter protects the sensor cover glass from damage as far as possible.
- Before exchanging the ground glass, turn the camera off with the main power switch and disconnect it from the power supply!
- Remove the lens or the protective cap.



Do not touch the mirror surface!



Do not touch the sensor cover glass surface!

- Using the special forceps (Hirschmann clamp) from the camera's toolkit, pull the ground glass out of the holder by its tongue ⇄ **image**.



- Check that the ground glass to be inserted as well as the ground glass frame is completely clean.
- With the special forceps, push the chosen ground glass into the holder as far as it will go. The red marker point must be on the left looking into the camera lens compartment. A ball catch fixes the ground glass exactly in the right position.
- Check that the ground glass is correctly locked in place.

Note: Cleaning or exchanging the field lens, see chapter 13: Camera Care.

Note: When the D-21 is set to output using the HD modes HD444 or HD422, the camera always outputs images at 1.78:1 (16:9) aspect ratio using

the full sensor aperture width. To utilize the full sensor aperture width and height with the aspect ratio of 1.33:1 (4:3), the camera has to be set to output Mscope or data mode/ARRIRAW^[2]. Different aspect ratios (e.g. 1.85:1) can be achieved by cropping the output image in postproduction.

6.4. ARRIGLOW

The ARRIGLOW module is integrated in the viewfinder system of the D-21. It allows illuminated format markings to be superimposed onto the viewfinder image with continuously adjustable brightness.

- To adjust the brightness of the illuminated format markings turn the adjustment knob ⇄ **image**.
- To turn off the ARRIGLOW, turn the adjustment knob counter-clockwise as far as it will go.

Exchanging the ARRIGLOW Mask

Each of the ground glasses available for the D-21 should be used together with a matching glow mask. For a list of available formats, please check the D-21 price list. To exchange the glow mask:

- Remove the viewfinder system as explained above.
- Turn the viewfinder upside down and put it on a clean surface that is covered with foam material or clean, lint-free cloth.

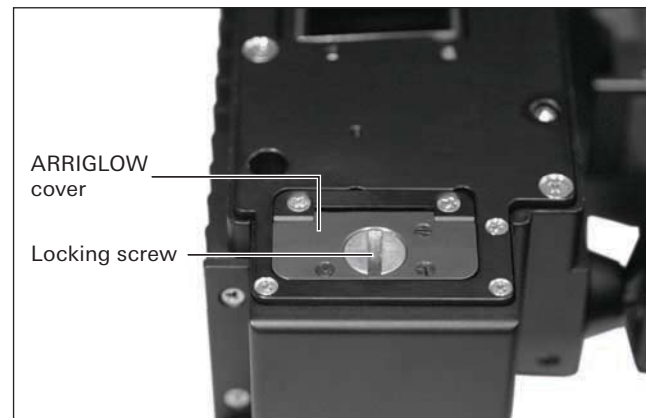

[2] Data mode output not available on the D-21 HD.

- Open the ARRIGLOW cover by gently turning the locking screw 90° counter-clockwise ⇨**image**.
- Using the special forceps (Hirschmann clamp) from the camera's toolkit, grab the glow mask at the forceps hole and pull it out of the holder ⇨**image**.
- Check that the glow mask to be inserted as well as the glow mask frame is completely clean.
- Carefully push the glow mask into the holder with the slanted edge facing towards the rear end of the viewfinder system ⇨**image** without tilting it in the holder's guides.
- Make sure the glow mask is inserted completely.
- Close and lock the glow mask door by gently turning the locking screw 90° clockwise.
- Attach the viewfinder system.
- Turn on the ARRIGLOW and check that ground glass and glow mask are correctly aligned.

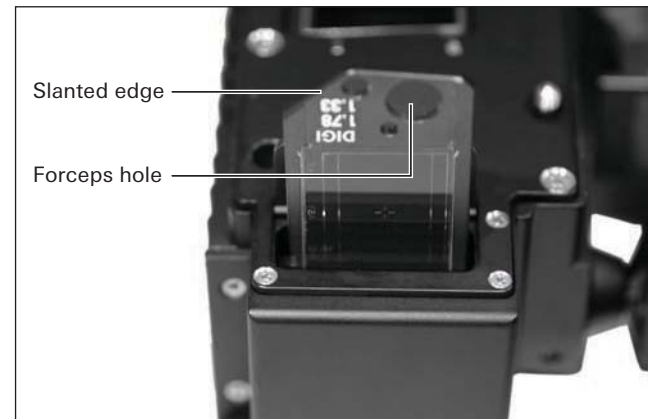
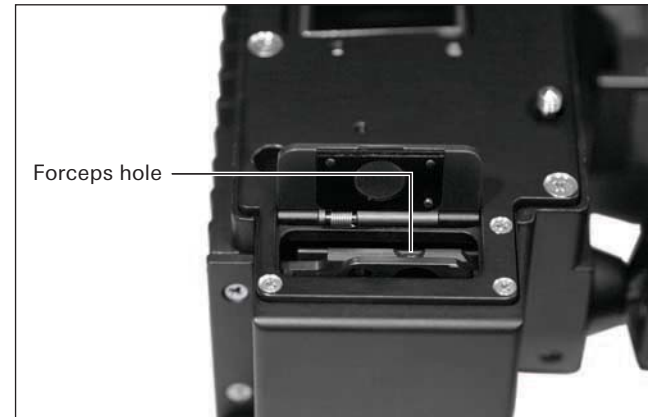

7. Camera Output Configuration

7.1. Output Interfaces^[1]

The ARRIFLEX D-21 has three output boards providing HD and SD outputs on the back of the camera.

- Two dual link HD-SDI outputs^[1] (HD-SDI 1 and 2) are located on the bottom right side ↪**image**. Both BNC connectors on the top right are for service purposes.
- Two composite video outputs (CVBS 1 and 2) and an S-Video output (Y/C) are located on the bottom left side ↪**image**.

7.2. Video Menu

Most operational parameters for the ARRIFLEX D-21 are set using a video menu. The video menu is shown as an on screen display on all SD video outputs.

Note: Configuration of the camera outputs requires an SD monitor to be connected to one of the composite video outputs or the S-Video output.

Note: Additional functions, including mirror shutter angle and programmable frame rates, are controlled using the camera display, located at the front left side of the camera ↪**image**. See chapter 9: Camera Operation for instructions.

[1] ARRIFLEX D-21 HD is equipped with one HD output board. Individual configuration options for second HD-SDI output do not apply.

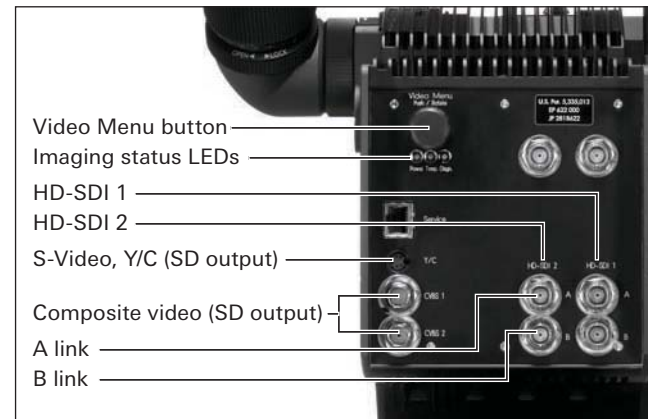

Using the Video Menu

- Briefly press the video menu button **image** to display the video menu on the connected SD monitor.
- Rotate the video menu button to select an operational parameter.
- Briefly press the video menu button to enter the options submenu.
- Rotate the video menu button to select an option in the submenu.
- Briefly press the video menu button to use or confirm the selection.
- Use "Cancel" to leave the submenu without changing the setting.
- Use "Exit" to leave the SD Mode - and Diagnostics submenus or to leave the video menu.

To avoid unintentional operation of the video menu, the video menu button can be deactivated with the LOCK switch **image** in the front left side of the camera.

Note: Rotating the video menu button while no menu is displayed accesses the OSD Tools (see: OSD Tools at the end of this chapter).

Note: The D-21 sensor readout operates at full sensor aperture with 1.33:1 (4:3) aspect ratio up to a standard frame rate of 25 fps. For frame rates of 29.97 or higher, readout operates at a reduced height with 1.78:1 (16:9) aspect ratio while retaining the full sensor aperture width.

The camera image in the SD video output therefore shows a 4:3 image up to 25fps and a 16:9 letterbox display for 29.97 fps and above.

Note: The SD video output can be set to output 50 Hz PAL/60 Hz NTSC video (see: SD Mode). The SD video format is independent of the camera's frame rate setting.

Status Indications

When changes are applied in the video menu, the camera will show a combination of these status indications:

Symbol	Meaning
Operation control LED glows red and/or when in standby, 1st line of camera display shows busy indicator " _o_ "	Camera is not ready. Do not operate/turn off camera before the operation control LED turns off.
Imaging status LEDs change state (red or off)	Applying settings to output electronics. Do not operate/turn off camera before all three imaging status LEDs turn green.

7.3. Setting Operational Parameters

User Mode

The camera can be configured using two different user modes:

- "Standard Mode" provides the quickest and easiest way to configure the camera for HD mode output. All output boards are configured with the same settings. Standard mode should be the preferred setup mode as long as the extended options from advanced mode do not need to be accessed.
- "Advanced Mode" provides additional options for settings that are automatically set in standard mode and enables the options for data mode/ARRIRAW output^[2] and the use of log output characteristics for HD mode.

Note: Faulty configuration in advanced mode can affect image quality of the camera output.

```

Main Menu
-----
User Mode:          Standard
White Balance:     3200 K
→ Framerate:       25PsF
HD-SDI Mode:       HD422
Output Range:      Normal Range
Contrast Char.:    EI 200
SD Mode
Diagnostics
Exit
    
```

```

Main Menu
-----
User Mode:          Advanced
White Balance:     3200 K
Framerate:         24PsF
Output Board:      ALL (1>2>SD)
→ HD-SDI Mode:     HD444           12-
Output Range:      RGB Norm.       12-
Colour Matrix:     3200 K           12S
Contrast Char.:    EI 250           12S
SD Mode
Diagnostics
Exit
    
```

[2] Data mode output not available on the D-21 HD.

To switch user modes:

- Enter "User Mode".
- Select and confirm the desired user mode.
- Switching to standard mode requires no further interaction.
- Advanced mode has to be unlocked by entering "2020" in the "Enter Code" screen:
- Briefly press the video menu button to access the first digit.
- Rotate the video menu button to select the first number.
- Briefly press the video menu button to enter this number.
- Access, select and enter the remaining digits (zeros can be skipped).
- Confirm switching to advanced mode using "OK".

Note: If the wrong code is entered, user mode switching is cancelled.

Note: When switching from advanced to standard mode, custom settings made in advanced mode will be reset to standard mode defaults. HD-SDI 2 configuration will default to the same settings as those for HD-SDI 1.

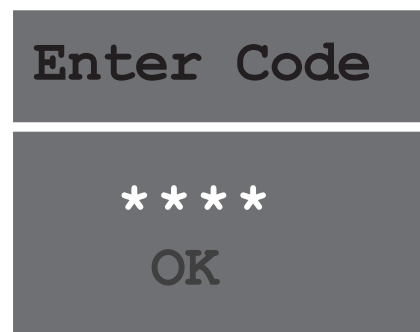
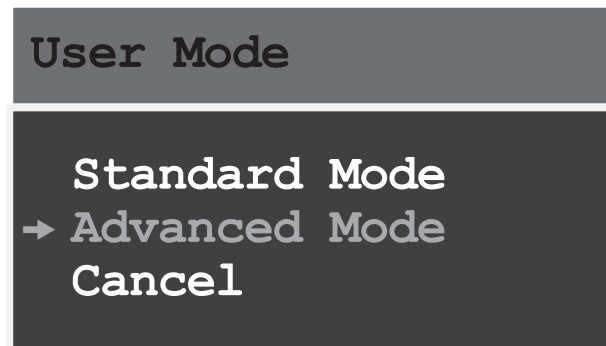

White Balance

Similar to choosing tungsten or daylight film stock, the D-21 has to be adjusted for the lighting used in a scene. The camera offers a selection of commonly used color temperatures, as well as an automatic and manual white balance function in case the preset values do not deliver satisfying results.

Note: Manual white balance is only available in advanced mode.

To adjust the camera to the lighting situation:

- Enter "White Balance" ↪ **image**.
- Select and confirm a preset color temperature (3200, 4300, 5600 or 7000 K) or a previously saved automatic or manual white balance setting (WB 1 - 3).

Automatic White Balance

To perform an automatic white balance:

- If the camera is not running, briefly press the RUN button.
- Point the camera at a homogeneously lit, neutral grey surface.
- Using a waveform monitor or the RGB- or LUM-Histogram (see: OSD Tools), adjust iris or lighting so the output video level lies within 40 to 70%.
- Enter "White Balance", "Automatic" ↪ **image**.
- Make sure that the measuring window is covered by the neutral grey surface.

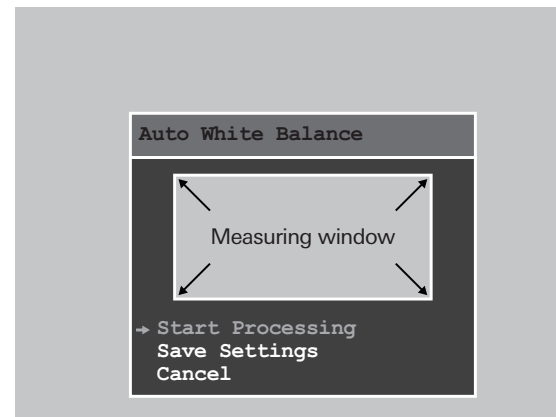
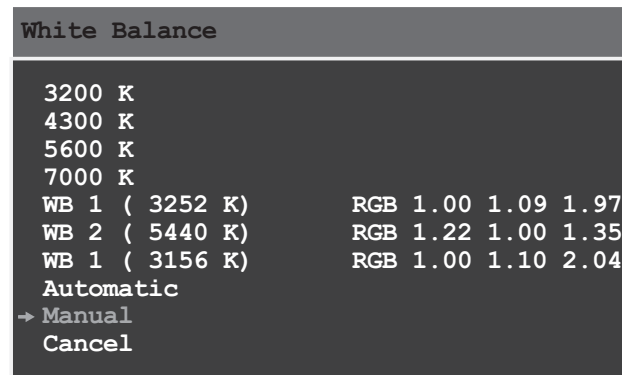

- Use "Start Processing" to start white balance processing.

When the camera finished processing, the OSD will show the values for the red, green and blue channels and the calculated color temperature (CCT).

- Confirm the results with "OK".
- Use "Save Settings".
- Select and confirm a slot (WB 1-3) to save the automatic white balance settings. When saved, the white balance setting is automatically applied.

Note: If the camera is not running, the OSD will show "Image not available!"

Note: If it is not possible to calculate a color temperature from the processed white balance values, the menu will show "CCT: out of range". These values can be saved, used and will not produce out of gamut errors, but no color temperature can be given.

Note: Automatic white balance settings should be checked with a waveform monitor in RGB waveform parade mode or vector scope mode. See: Color Matrix below for additional information.

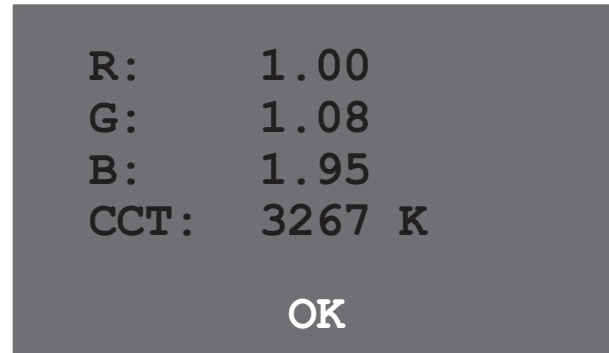

Manual White Balance (Advanced Mode)

Manual white balance can be used to fine-tune the preset or automatic white balance settings. To apply a manual white balance:

- If the camera is not running, briefly press the RUN button.
- Enter "White Balance", "Manual" ⇨ **image**.
- Use "R:" to select and enter a value for the red channel gain.
- Use "G:" to select and enter a value for the green channel gain.
- Use "B:" to select and enter a value for the blue channel gain.
- Use "Save Settings".
- Select and confirm a slot (WB 1-3) to save the manual white balance setting. When saved, the white balance setting is automatically applied.

Note: The initial values for R, G and B are based on the previously used white balance setting.

Note: Manual white balance settings should be checked with a waveform monitor in RGB waveform parade mode or vector scope mode. See: Color Matrix below for additional information. Manual white balance settings are indicated in the video menu as "(man. defined)" instead of a color temperature.

Standard Frame Rate

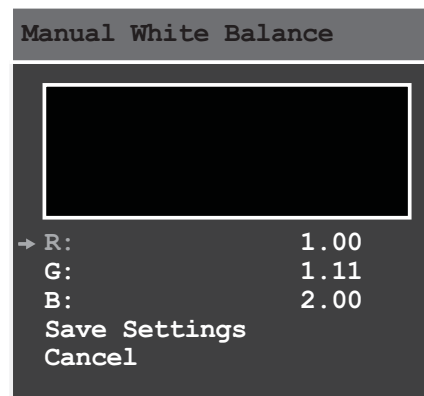

The D-21 can be set to run at:

- standard frame rates (23.976, 24, 25, 29.97, 30, 48, 50, 59.94 and 60 fps^[3]), set in the video menu and
- programmed or variable speeds between 1 and 60 fps^[4] (0.001 fps increments), set using electronic accessories or the PS mode of the camera menu.

To set the camera to a standard frame rate:

- If the mirror shutter is running, stop the camera by pressing the RUN button.
- Enter "Frame Rate" ⇄ **image**.
- Select and confirm a standard frame rate from the list.
- Wait for the operation control LED to turn off before operating the camera.

Note: While the frame rate setting is applied, the operation control LED lights up red. Operating or restarting the camera before the LED turns off may cause the camera to run at the wrong speed.

To set the camera to a programmed/variable frame rate:

- First set the required standard system frame rate as described above, then proceed setting a custom speed using electronic accessories or the PS mode as described in chapter 9: Camera Operation.

[3] ARRIFLEX D-21 HD can be set to run at standard frame rates of 23.976, 24, 25, 29.97 and 30 fps.

[4] ARRIFLEX D-21 HD is limited to programmed/variable speeds between 1 and 30 fps.

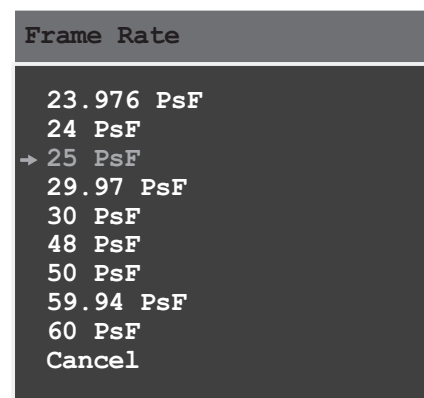

Note: The range of standard frame rates available for selection depends on the settings made for the HD-SDI mode and vice versa. HD444 and ARRIRAW limit the speed to 30 fps. Mscope limits to 25 fps. Frame rates of 30 fps or higher limit the HD-SDI mode to HD422 and lock individual HD-SDI 2 configuration, as both outputs are required for signal transmission. Also see: HD-SDI Mode – Overview of Available Output Formats.

Note: The standard frame rate set here determines the maximum frame rate selectable for programmable/variable speeds.

Note: The SD output always delivers 50 Hz PAL/60 Hz NTSC signals, regardless of the frame rate setting.

Output Board (Advanced Mode)^[5]

The settings for white balance and frame rate apply as a system-wide setting. Settings for HD-SDI mode, output range, color matrix and contrast characteristic can be applied to all output boards at once or to each board individually.

Note: It is recommended to first set a basic configuration for all outputs using "ALL (1>2>SD)" and then adjust parameters that need to be customized for the second output "HD-SDI 2" and/or "SD".

To select the output board to be configured:

- Enter "Output Board" ⇨ **image**.
- Select and confirm "ALL (1>2>SD)", "HD-SDI 1", "HD-SDI 2" or "SD".

Note: Using "ALL (1>2>SD)" assigns the subsequent settings made for HD-SDI mode, output range, color matrix and contrast characteristic to all output boards and – as far as applicable – to the SD output.

Note: Using a frame rate of 30PsF or higher, disables the HD-SDI 2 option, as both output boards are required for signal transmission.

Output Board

→ ALL (1>2>SD)
HD-SDI 1
HD-SDI 2
SD
Cancel

[5] ARRIFLEX D-21 HD only offers one HD-SDI output board. It is recommended to always use "ALL (1>SD)" for configuration of this model.

Setup Information Digits

Three digits shown next to the settings for HD-SDI mode, output range, color matrix and contrast characteristic ↔**image** provide basic information, which of the outputs are using the same or different settings for these parameters (also see table below). The information is based on the parameters of the currently selected "Output Board".

Note: When "ALL (1>2>SD)" is selected, the setup information digits base on the HD-SDI 1 configuration.

The example ↔**image** shows the setup for output board HD-SDI 1:

- HD-SDI 2 is set to a different HD-SDI mode and output range.
- Both settings do not apply for the SD output.
- The settings for color matrix and contrast characteristics are the same for all outputs.

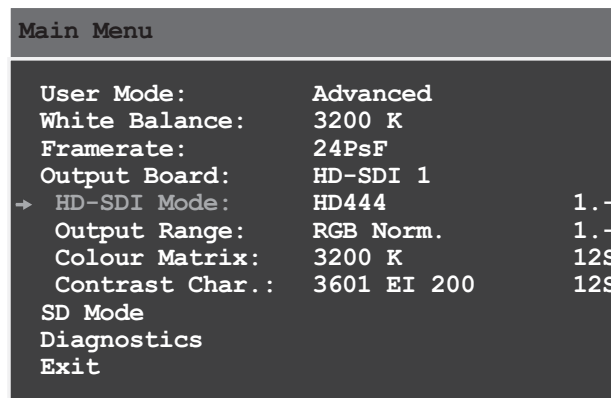

Symbol	Meaning
1	Setting applies to HD-SDI 1.
2	Setting applies to HD-SDI 2.
S	Setting applies to SD output.
.	Setting does not apply to HD-SDI 1, HD-SDI 2 or SD, depending on which digit the period is on.
-	Setting is not available for SD output.

HD-SDI Mode^[6]

The HD-SDI mode identifies the type of signal output for HD-SDI 1 and 2. The Data mode/ARRIRAW option is only available in advanced mode setup.

Note: The HD-SDI mode that can be selected depends on the settings made for the standard frame rate and vice versa. HD444 and ARRIRAW output limit the maximum speed to 30 PsF. Mscope limits to 25 fps. Frame rates of 30 fps or higher limit the HD-SDI mode to HD422 and lock individual HD-SDI 2 configuration, as both outputs are required for signal transmission. Also see: Overview of Available Output Formats below.

To set the HD-SDI mode for the selected output board:

- Enter "HD-SDI Mode" ⇄ **image**.
- Select and confirm an HD-SDI mode from the list.
- If the signal was set to "Extended" output range before, re-apply this setting.

Note: Selecting ARRIRAW here switches to data mode, which disables the options for output range, color matrix and contrast characteristic, as these adjustments are not applied for this output mode.

Note: When using ARRIRAW for recording and HD output for preview, it is recommended to set HD-SDI 1 to an HD mode (HD444, HD422 or Mscope) and HD-SDI 2 to ARRIRAW output.

[6] ARRIFLEX D-21 HD does not offer ARRIRAW output.

Mode HD-SDI ALL

→ HD422
 HD444
 Mscope HD422
 ARRIRAW
 Cancel

After applying the HD-SDI modes, change "Output Board" to "ALL(1>2>SD)". All parameters can now be set more conveniently for both HD-SDI 1 and SD output at the same time, whereas non applicable settings will be ignored for the ARRIRAW output. "HD-SDI Mode", however should remain untouched as this would also change the ARRIRAW output to the new setting.

Note: Changing the HD-SDI mode always resets the output range to "Normal Range".

Note: HD-SDI mode configuration does not apply to the SD output.

Overview of Available Output Formats^[7]

HD-SDI mode	ARRIRAW		HD444 (4:4:4 RGB)	HD422 (4:2:2 YCbCr)		Mscope (4:2:2 YCbCr)
Output resolution	2880 x 2160	2880 x 1620	1920 x 1080	1920 x 1080	1920 x 1080	1920 x 1440
Aspect Ratio	1.33:1 (4:3)	1.78:1 (16:9)	1.78:1 (16:9)	1.78:1 (16:9)	1.78:1 (16:9)	1.33:1 (4:3)
Connection Type	ARRIRAW T-Link	ARRIRAW T-link	dual link HD-SDI	single link HD-SDI	dual link HD-SDI	dual stream HD-SDI
Output range	not available	not available	normal/ extended	normal/extended	normal/extended	normal/extended
Standard frame rates	23.976, 24, 25	29.97, 30	23.976, 24, 25, 29.97, 30	23.976, 24, 25, 29.97, 30	48, 50, 59.94, 60	23.976, 24, 25
Available fps range	1 – 25	1 – 30	1 – 30	1 – 30	1 – 60	1 – 25

Note: Data mode/ARRIRAW requires an ARRIRAW T-Link certified recorder or a system capable of recording uncompressed, SMPTE 372M compliant RGBA HD-SDI signals. For more information see chapter 15: Appendix.

Note: Mscope requires a recorder capable of dual stream HD recording - i.e. two simultaneous 1920 x 1080 4:2:2 YCbCr HD video streams.

Note: Wiring instructions for all HD-SDI modes can be found in chapter 8: Signal Connections.

[7] ARRIFLEX D-21 HD does not offer ARRIRAW output.

Output Range (Advanced Mode)^[8]

The output range determines the signal range of the output HD video signal. Normal range (also called legal/standard/safe range) corresponds to video levels between 0 and 100%. Extended range (also called full range) corresponds to video levels between approx. -10 and 110%.

To set the output range for the selected output board:

- Enter "Output Range" ↔ **image**.
- Select and confirm an output range from the list.

Note: Be aware that changing the output range using "Output Board: ALL(1>2>SD)" will change the output range for both HD-SDI output boards simultaneously. If one output board shall provide "Normal Range" and the other one "Extended Range", the output range must be configured using "Output Board: HD-SDI 1 and 2" individually.

Note: Output range is automatically set to "Normal Range" in standard mode.

Note: Using ARRIRAW as HD-SDI mode for an output disables this parameter.

Note: Changing the HD-SDI mode always resets the output range to "Normal Range".

Note: Output range does not apply to the SD output.

[8] ARRIFLEX D-21 HD does not offer ARRIRAW output.

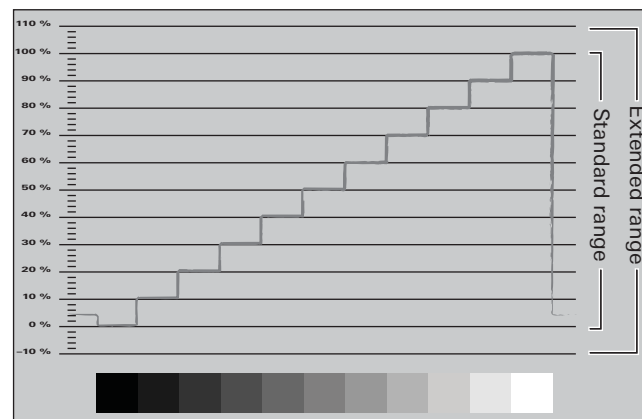

Color Matrix (Advanced Mode)

The color matrix applies a color transformation for the intended output colorspace.

The color matrix selection offers settings for each white balance preset and additional 125% and 75% saturation settings for tungsten and daylight. These settings are calculated for the ITU-R BT.709 color space and, in combination with EI characteristic curves (see below), are recommended for use in HD workflows.

The camera additionally provides a LOG setting for use in DI workflows. This matrix is based on film densities to provide a color rendition that closely matches negative stock and is recommended in combination with the logarithmic characteristics setups (see next page).

To set the color matrix for the selected output board:

- Enter "Color Matrix" ⇨ **image**.
- Select and confirm a color matrix from the list.

Note: The camera does not offer optimized color matrix settings for automatic or manual white balance values. For automatic or manual settings, it is recommended to select the color matrix delivering the best match to the set white balance. This should be evaluated using a color checker chart and a vector scope.

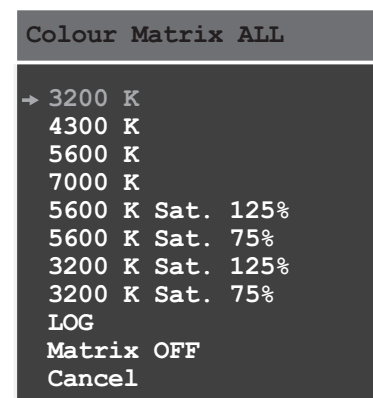

Suitable Combinations of Contrast Characteristics, White Balance and Color Matrix

Contrast Characteristic	EI 100 – 800						LOG C LOG F
	White Balance	3200 K	4300 K	5600 K	7000 K	automatic	manual
Color Matrix	3200 K 3200 K 75% 3200 K 100%	4300 K	5600 K 5600 K 75% 5600 K 100%	7000 K	best match	best match	LOG

Contrast Characteristics

The ARRIFLEX D-21 offers two types of characteristic curves:

Exposure Index (EI) characteristic curves, intended for immediate HD output.

LOG characteristic curves, intended for use in DI- or Filmstream™ oriented workflows.

To set the contrast characteristic curve for the selected output board:

- Enter "Contrast Char." ⇨ **image**.
- Select and confirm one of the contrast characteristics from the list.

Note: LOG C and LOG F are only available in advanced mode setup.

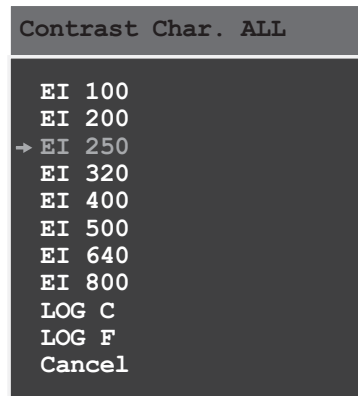

El characteristic curves

The EI characteristic curves base on the average tonal representation of negative film stock. The exposure index values are calculated ISO equivalents to facilitate measuring the correct lens aperture using an exposure meter. For each EI, a different transfer function (non-linear gain) is applied to keep middle grey (18%) at a constant signal output level. As these curves provide an immediate sensitivity adjustment, they are recommended for use in HD productions.

EI – Sensitivity and Dynamic Range Distribution

Please note that working with different EI values is different from the traditional film exposure paradigm. Film stock of different sensitivity maintains its overall dynamic range distribution. Changing EI characteristic curves influences the dynamic range distribution.

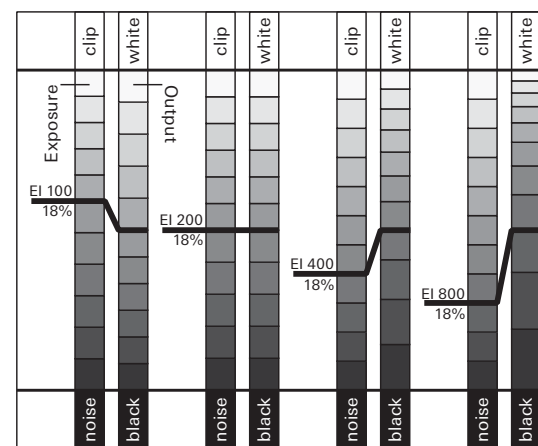

A higher EI value allows the sensor to be exposed with less light. As a result, the sensor delivers less range below middle grey, but an increased range for capturing highlights ↔**image**.

A lower EI value provides more range below middle grey, but less range for highlights.

It is recommended to select the EI characteristic curve depending on the intended dynamic range distribution, while proper exposure should be ensured by sufficient lighting.

Camera Configuration

The EI characteristic curves shipped with this camera provide a dynamic range distribution of about 55% above and 45% below middle grey at an ISO equivalent/ EI of 200. An 18% grey is matched to 36 % video level. The dynamic range distribution shifts to a ratio of:

- about 60% above and 40% below at EI 800 and
- about 40% above and 60% below at EI 100.

Note: The contrast characteristics shown here are for illustration only and may differ from the actual curves supplied with the color management software version installed in your camera.

Recommended EI Setup

- HD-SDI Mode: HD422 or HD444
- Output Range: according to HD-SDI mode
- Color Matrix: according to white balance

EI characteristic curves

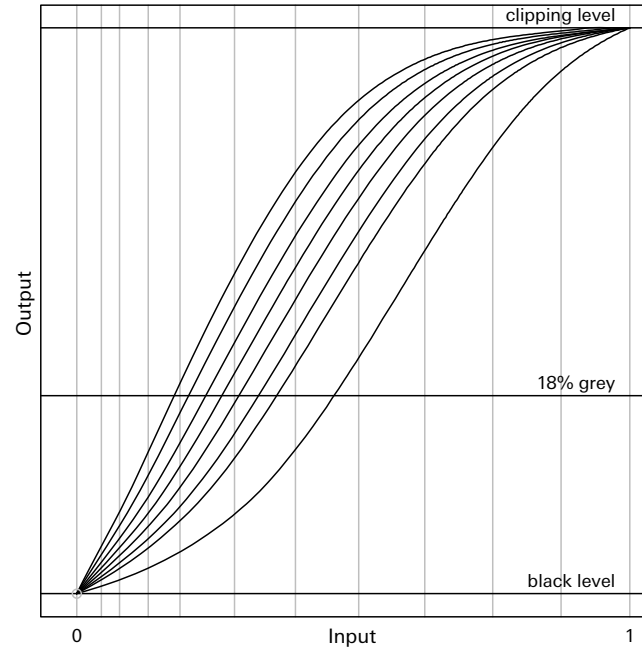

LOG C (Advanced Mode)

The LOG C characteristic curve provides a signal output according to Cineon format specifications. Each stop of exposure is mapped in equal intervals of digital code values. This characteristic is intended for use in a DI workflow, as it delivers the same tonal steps representation as the scans from a film negative. LOG C delivers an ISO equivalent/EI of 200. When LOG C is used, the EI cannot be adjusted in the camera. The tonal balance of the signal has to be adjusted using LUTs or through color correction.

Recommended LOG C Setup

- HD-SDI Mode: HD444 up to 30PsF
- Output Range: Extended Range
- Color Matrix: LOG

Note: When using LOG C, the correct lens aperture should be determined using an exposure meter. On a waveform display, a correctly exposed image is offset in the blacks and does not reach the maximum signal level due to the given specifications.

Note: To correctly preview the material on an HD monitor or in a digital projection, a log/lin conversion LUT (optionally also adjusting for an EI) has to be applied.

LOG C characteristic curve

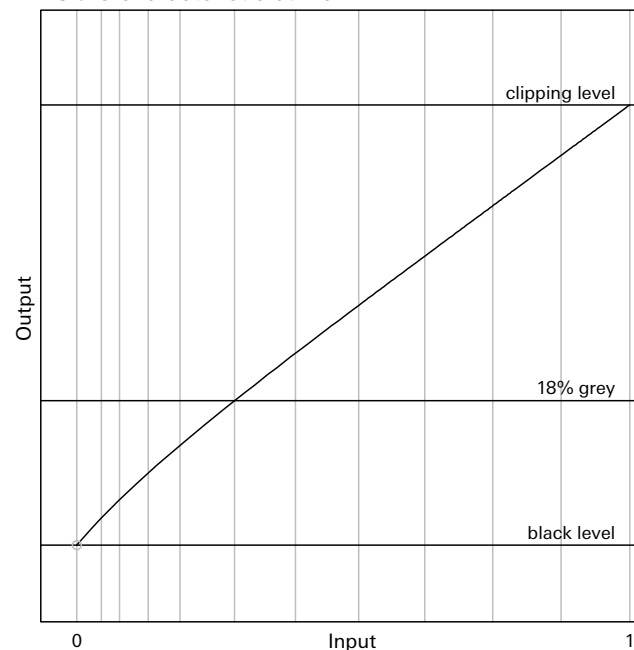

LOG F (Advanced Mode)

The LOG F characteristic curve provides a signal according to Filmstream™ specifications. This characteristic is intended for HD workflows adapted to Filmstream™ signals. LOG F delivers an ISO equivalent/ EI of 200. When LOG F is used, the EI cannot be adjusted in the camera. The tonal balance of the signal has to be adjusted using LUTs or through color correction.

Recommended LOG F Setup

- HD-SDI Mode: HD444 up to 30PsF
- Output Range: Extended Range
- Color Matrix: LOG

Note: As with LOG C, the correct lens aperture should be determined using an exposure meter. On a waveform display, the mid-tones of a correctly exposed image will be offset and highlights will not reach the maximum signal level due to the given specifications.

Note: To correctly preview the material on an HD monitor a Filmstream™/lin conversion LUT, optionally also adjusting the EI, has to be applied on the signal. As the D-21 only adopts the characteristic curve, the camera image will not show a green color cast.

Note: This characteristic curve has been designed by a different company and for a different camera. It is not optimized for the ARRIFLEX D-21.

LOG F characteristic curve

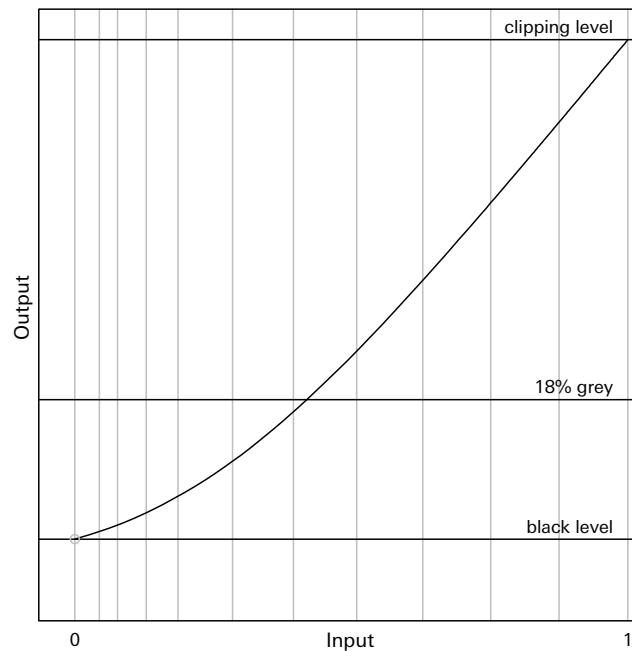

SD Mode

The SD mode menu is used to change the settings for the output zebra and the format markings displayed on the composite video and S-Video outputs, and to adjust the SD output to the video format of the connected SD monitor.

Output Zebra Setup

The Output Zebra shows a slanted color pattern overlay in image areas reaching the set threshold exposure level. It is only available on the SD output of the camera.

To activate and configure the viewfinder zebra:

- Enter "SD Mode", "Output Zebra" ⇄ **image**.
- Use "High" and/or "Low Zebra" to activate or deactivate the function.
- Use "High" and/or "Low Zebra Level", to enter the threshold video levels.
- Use "High" and/or "Low Zebra Color" to change the zebra pattern color.
- Use "Exit" to quit the output zebra setup.

Note: High and Low Zebra operate independently and remain active above the set thresholds. It is not possible to set the Zebra to be active only between low and high level.

Note: The output zebra is part of the OSD tools (see: OSD Tools below).

SD Mode

```

→ Output Zebra:      Off
   SD Video Mode:    NTSC
   Format Marking:    1.78:1
   Cancel
    
```

Output Zebra

```

→ High Zebra:        Off
   High Zebra Level:  83.0%
   High Zebra Colour: Red
   Low Zebra:         Off
   Low Zebra Level:   20.0%
   Low Zebra Colour:  Yellow
   Cancel
    
```

SD Video Mode

To adjust the SD video output to 50 Hz PAL or 60 Hz NTSC format for the SD monitor in use:

- Enter "SD Mode", "SD Video Mode" ↔**image**.
- Select and confirm the desired output format.

Format Marking Setup

The camera can show a preset or custom format marking as an overlay on the connected SD monitor. Format markings are only available on the SD output of the camera. Available presets are 1.78:1, 1.85:1, 2.35:1 and 1.33:1 (HD Crop - shows a center crop 4:3 frame within the 16:9 image).

To select an aspect ratio for the format marking:

- Enter "SD Mode", "Format Marking" ↔**image**.
- Select and confirm an aspect ratio from the list.
- Use "Exit" to quit the format marking setup.

To setup and store a custom format marking:

- Enter "SD Mode", "Format Marking".
- Enter "Edit Format".
- Adjust the left border of the format marking and confirm.
- Repeat adjustment for right, upper and lower border.
- Select and confirm a slot (Format 1-3) to save the custom format marking ↔**image**.
- Select "Exit" to quit the format marking setup.

SD Video Mode

→ PAL
NTSC
Cancel

Format Marking

→ 1.78:1
1.85:1
2.35:1
1.33:1 (HD Crop)
Format 1
Format 2
Format 3
Edit Format
Cancel

Diagnostics

The diagnostics menu provides access to the camera status pages and allows performing a standard reset.

Status

The camera status is shown in three pages:

Status 1 ⇨ **image** displays information on general camera status and output board configurations.

Status 2 ⇨ **image** displays camera system check status, CRC and version information for the color management (CM).

Status 3 ⇨ **image** displays internal temperature and voltage readings.

Status 1	Status 2	Status 3
Camera Status: RUN Shutter Mode: ROTATING Shutter Pos.: ROTATING Shutter Angle: 180.00 Image Size: 2880x2160 Framerate: 25.000 fps CDS: ON Mode HD-SDI 1: HD422 Mode HD-SDI 2: HD422 → Next Exit	ECU: OK! SENSOR: OK! ADGOC0: OK! ADGOC1: OK! ADGOC2: OK! ADGOC3: OK! PIM1: OK! PIM2: OK! CRC: CM: → Next Back	Sensor Temp: 32.0 °C Sensor Board Temp: 30 °C ECU Board Temp: 36 °C VDD 2.5 V: 2433 mV VDD 3.3 V: 3243 mV VDD 5.0 V: 4988 mV VDD 8.0 V: 8052 mV → Next Back



The Diagnostics menus should always be exited before a recording is started.

To access the status information:

- Enter "Diagnostics", "Status".
- Use "Next" to proceed to the next Status page.
- Use "Back" to go to the previous Status page.
- Use "Exit" to leave the Diagnostics menu.

Status and Imaging Status Indications

The imaging status LEDs on the back of the camera provide basic information on the general status of the camera's imaging- and image-processing module.

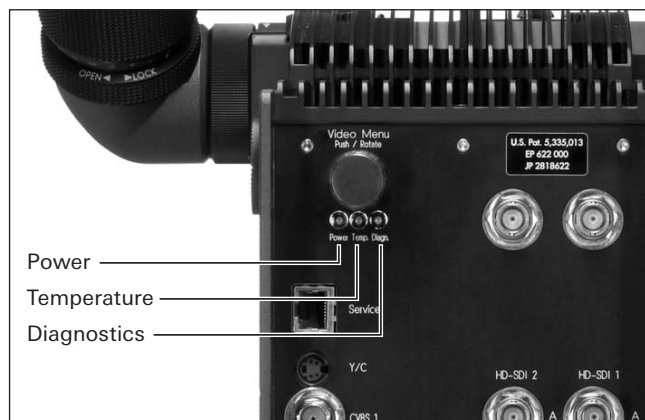

Indicator		Meaning
Diagnostics	Green	All system checks normal.
	Red	One/more system check failed. Restart camera. Perform standard reset. Take camera to ARRI service center if problem persists.
Temperature	Green	Sensor temperature at nominal level.
	Off	Slight sensor temperature deviation from nominal level. Turn camera off and wait 5 minutes before turning it back on. Make sure that air can flow through the ventilation shafts at the back of the camera body.
	Red	Sensor temperature deviation from nominal level above acceptable limit. Possible malfunction of internal cooling system. Turn camera off and wait 5 minutes before turning it back on. Make sure that air can flow through the ventilation shafts at the back of the camera body. Take camera to ARRI service center if problem persists.
Power	Green	Internal power supply levels normal.
	Red	Problem with internal power supply. Restart camera. Take camera to ARRI service center if problem persists.
	Red blinking	Standard reset performed. Restart camera to complete.

Note: The integrated cooling system keeps the CMOS imager at a constant 32 °C. When the camera is operated in high temperatures, it may be necessary to support the internal cooling by means of an external fan, which is available as an optional accessory.

Standard Reset

A standard reset restores the factory settings for user-accessible and internal controls of the image-processing module. To perform a standard reset:

- Enter "Diagnostics", "Standard Reset".
- Confirm the standard reset by entering "Yes", or cancel by entering "No".
- When the power LED on the camera backside starts blinking red, restart the camera using the main power switch to complete the standard reset. The camera will return to the user mode it was set to when the standard reset was performed.

After a standard reset, the camera will default to these settings:

White Balance: 3200 K
 HD-SDI Mode: HD422 25PsF
 Output Range: Normal Range (YCbCr)
 Color Matrix: 3200 K (not displayed in Standard User Mode menu)
 Contrast Char.: EI 200
 SD Video Mode: PAL

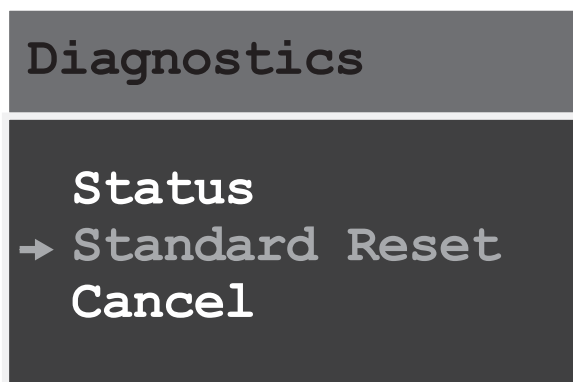

7.4. OSD Tools

The SD output of the ARRIFLEX D-21 provides a set of OSD tools: an adjustable format marking with preset or custom aspect ratio, a viewfinder/output zebra, an RGB-histogram, separate R, G, B and LUMINANCE histograms.

To access the OSD Tools:

- Exit the video menu if it is displayed.
- Rotate the menu button to step through the tools.

Note: The viewfinder/output zebra is setup using the video menu. See section SD Mode.

Note: The histogram always refers to the settings of the SD output.



8. Signal Connections

Using HD Mode output, the ARRIFLEX D-21 can be connected to any HD recording device that offers HD-SDI input and 1080psf/i recording. The signal connection length should not exceed 40 m/130 ft using standard HD-SDI BNC cables. The signal connection length can be increased using high quality cables with low signal damping. If a signal is recorded via two connections (dual link), using two cables of the same length offers better signal performance.



If connection cables show any type of damage (crush/tear), they should be replaced immediately!



Only use HD-SDI compliant BNC cables for the signal connection! This ensures maximum signal quality and reliability. ARRI does not assume responsibility for incurred losses due to defective signal connections.

Note: The maximum length for reliable HD-SDI cable connections depends on the cable in use. The length stated in this manual is intentionally shorter than the length stated by most cable manufacturers to provide an increased signal safety level in case of minor defects.

8.1. Signal Wiring Instructions

The following examples show signal wiring instructions for different camera configurations as explained in the previous chapter. All setups requiring a single HD-SDI output board can be combined using advanced mode setup, i.e. HD422 up to 30 fps, HD444, Mscope and ARRIRAW^[9].

Note: It is generally recommended to verify correct signal recording. All examples include a control monitor for checking the recorded images. If a monitor/waveform monitor is used directly on the camera to check the signal output, it is recommended to feed the input signal from the recording system's monitoring outputs unless the recorded signal is checked using another control monitor. In applications, where the recorded signal cannot be monitored directly (e.g. shoulder- or steadicam application with a portable recording system mounted directly on the camera for untethered operation), the recording should always be checked as soon as possible (e.g. during or after transfer from portable system to tape or disk recording system).

Note: The shutter angles and frame rates shown in the illustrations are only used as examples for settings that match the corresponding digital setups.

[9] ARRIRAW output not available on the ARRIFLEX D-21 HD.

HD422 Setup (Standard Mode)

- Set "Frame Rate" up to 30 PsF.
- Set "HD-SDI Mode" to HD422.
- Set the recording system input format to 4:2:2 YCbCr 1080PsF/i using the frame rate set on the camera.
- Connect camera output HD-SDI 1 or 2, link A to recording input HD-SDI IN A.
- Connect recording output HD-SDI OUT A or HD-SDI monitor out to control monitor input HD-SDI IN A or B.

Note: When set to "HD422", the camera output boards transmit the same signal on link A and B. Using link A is recommended.

Note: Standard Mode setup assigns the same settings to all HD-SDI output boards. Individual output boards configuration requires advanced mode setup.

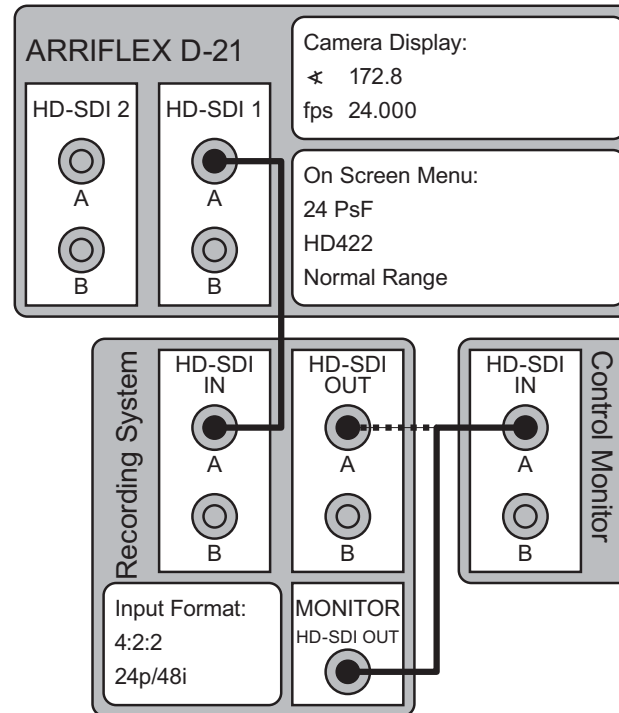

HD422 High Speed Setup (Standard Mode)^[10]

- Set "Frame Rate" between 48 and 60 PsF.
- Set "HD-SDI Mode" to HD422.
- Set the recording system input format to 4:2:2 YCbCr 1080PsF/i dual link using the frame rate set on the camera.
- Connect camera output HD-SDI 1, link A to recording input HD-SDI IN A.
- Connect camera output HD-SDI 2, link A to recording input HD-SDI IN B.
- Connect recording HD-SDI monitor out to control monitor input HD-SDI IN A or B.

Note: HD422 output above 30 PsF requires the use of two HD-SDI output boards. Each board outputs the same signal on link A and B. Using link A is recommended. Devices connected via single link on HD-SDI 1 or 2 will only receive every other frame.

Note: Recording HD422 output above 30 PsF using a dual link connection is not supported by all recording systems. Depending on the recording system, live monitoring of these signals may not be possible or restricted to output of every other frame. For more information on HD422 dual link output and recording system requirements, see chapter 15: Appendix.

Note: Please refer to the recording system's user manual for information and instructions on 48/50/59.94/60p 4:2:2 dual link recording.

Note: For information on custom frame rates and ramps see chapter 9: Camera Operation.

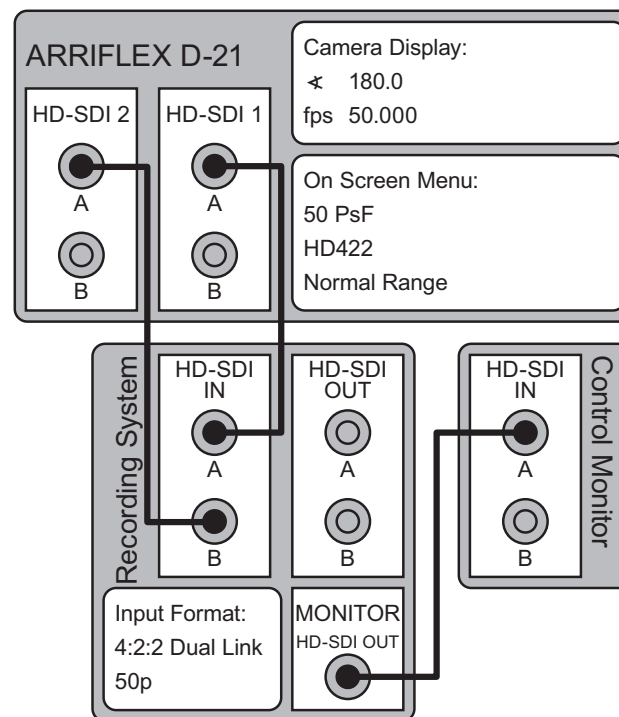

[10] HD422 high speed setup not available on the ARRIFLEX D-21 HD.

HD444 Setup (Standard Mode)

- Set "Frame Rate" up to 30 PsF.
- Set "HD-SDI Mode" to HD444.
- Set the recording system input format to 4:4:4 RGB 1080PsF/i dual link using the frame rate set on the camera.
- Connect link A of the configured output board to recording input HD-SDI IN A.
- Connect link B of the configured output board to recording input HD-SDI IN B.
- Connect recording HD-SDI monitor out to control monitor input HD-SDI IN A or B.

Note: HD-SDI output boards set to HD444 require link A and B for signal output. Always use link A and B from the same output board.

Note: Standard Mode setup assigns the same settings to all HD-SDI output boards. Individual output boards configuration requires advanced mode setup.

Note: If the control monitor supports 4:4:4 signals, recording outputs HD-SDI OUT A and B can also be connected to the control monitor inputs HD-SDI IN A and B.

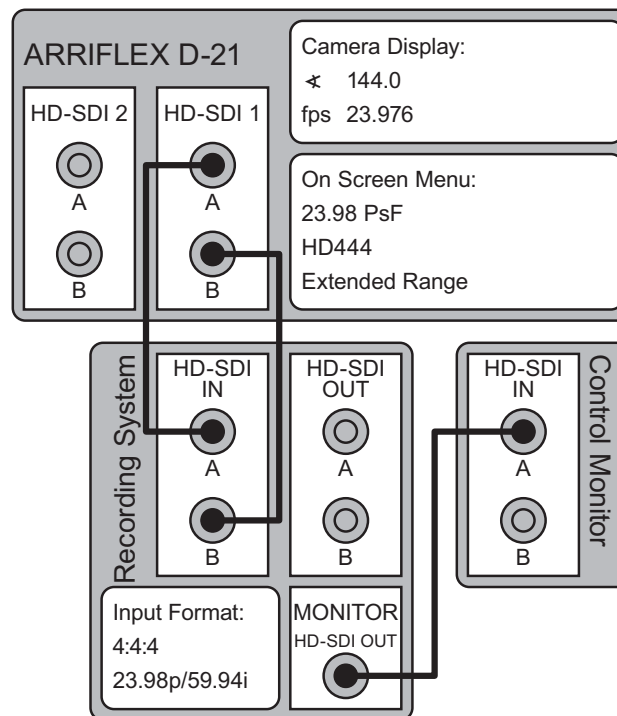

Mscope HD422 Setup (Standard Mode)

- Set "Frame Rate" up to 25PsF.
- Set "HD-SDI Mode" to Mscope HD422.
- Set the recording system input format to 4:2:2 YCbCr 1080PsF/i dual stream using the frame rate set on the camera.
- Connect link A of the configured output board to recording input HD-SDI IN A.
- Connect link B of the configured output board to recording input HD-SDI IN B.
- Connect recording HD-SDI monitor out to control monitor input HD-SDI IN A or B.

Note: HD-SDI output boards set to Mscope require link A and B for signal output. Always use link A and B from the same output board.

Note: Standard Mode setup assigns the same settings to all HD-SDI output boards. Individual output boards configuration requires advanced mode setup.

Note: Mscope is intended for use with anamorphic lenses. The full sensor area with a 4:3 aspect ratio is output as a 1920 x 1440 image using a dual link connection. Each link contains 1920 x 720 lines of the frame. A display connected to one camera link or the recorder's monitor OUT will display a de-squeezed preview image.

Note: Recording Mscope output using a dual stream connection is not supported by all recording systems. For more information on Mscope, see chapter 15: Appendix.

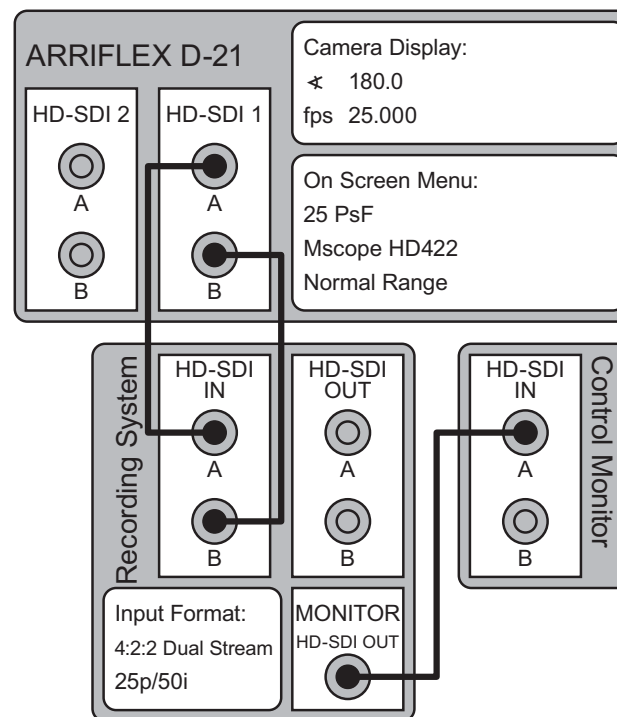

Data Mode/ARRIRAW Setup (Advanced Mode)^[11]

- Set "Frame Rate" up to 30 PsF.
- Set "HD-SDI Mode" to ARRIRAW.
- Set the recording system input format to ARRIRAW T-Link using the frame rate set on the camera.
- Connect link A of the configured output board to recording input A.
- Connect link B of the configured output board to recording input B.
- Connect recording HD-SDI monitor out to control monitor input HD-SDI IN A or B.

Note: HD-SDI output boards set to ARRIRAW require link A and B for signal output. Always use link A and B from the same output board.

Note: Data Mode setup is only available in advanced mode. The second HD-SDI output board can be set to all other modes using up to 30 PsF.

Note: ARRIRAW/data mode output can be recorded using ARRIRAW T-Link certified recorders or systems supporting RGBA HD-SDI streams according to SMPTE 372M. Recorders without ARRIRAW T-Link certificate may offer limited or no preview output. Please refer to the recording system's user manual for information and instructions on setting up ARRIRAW T-Link recording.

Note: For more information on Data Mode/ARRIRAW, see chapter 15: Appendix.

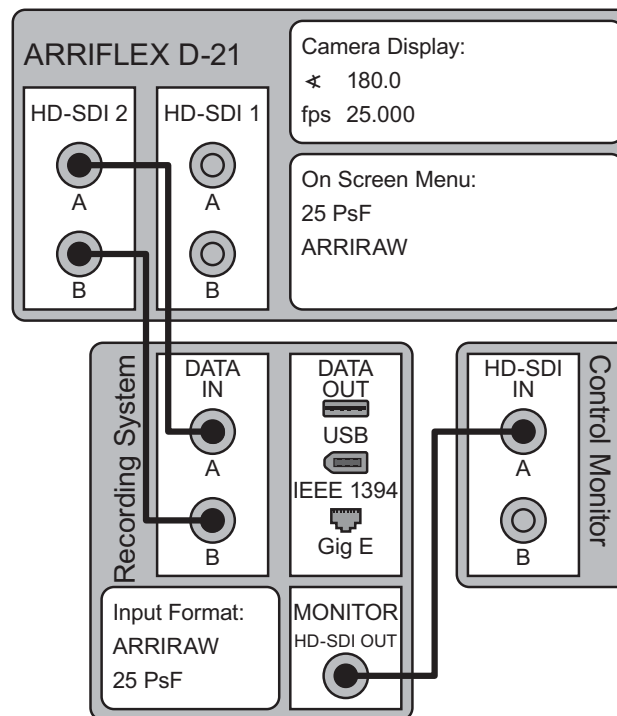

[11] ARRIRAW setup not available on the ARRIFLEX D-21 HD.

9. Camera Operation

9.1. Running and Stopping the Camera

The RUN button is located on the left side of the camera ⇄**image**.

Next to the RUN button is an operation control LED ⇄**image**. If the operation control LED glows red while in standby, the camera control electronics is not ready and the camera will not run.

Note: If the camera was just turned on, do not operate it before all three imaging status LEDs on the camera backside ⇄**image** light up green! Using any of the camera's buttons before it is ready for operation may cause faulty behavior.

When the camera is in standby, it outputs a black image or a still frame. To start or stop the camera:

- Briefly press the RUN button.

The operation control LED glows red when the mirror shutter starts or stops spinning. Once the set frame rate has been reached, the operation control LED turns green.

Note: Running and stopping the camera does not necessary start and stop the recorder. See chapter 10: Recording for more information.

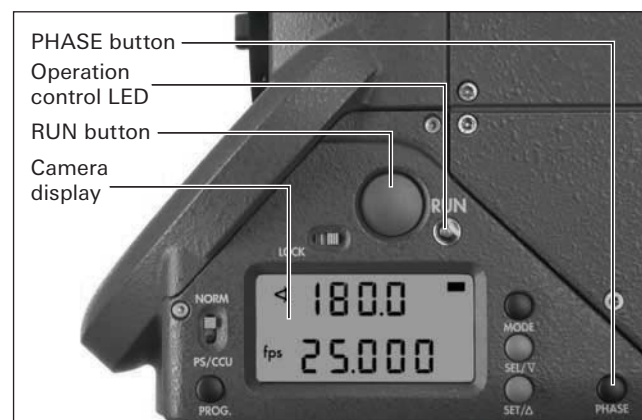

Note: The mirror shutter stops in the same position it was set to before it was started. If no image can be seen through the viewfinder, briefly press the PHASE button to rotate the mirror into viewing position.

Note: As part of the daily routine of camera care, it is recommended to perform an imager check prior to or at the end of each day of shooting to ensure the camera's imager has not taken any mechanical or electrical damage. Detailed information on checking the imager can be found in chapter 13: Camera Care.

9.2. Camera Display Modes

The camera display at the front left side of the camera ⇄**image** is used to display/adjust parameters connected with the imager's exposure. Access to these parameters is provided through different display modes.

To change between modes:

- Briefly press the MODE button ⇄**image**.
- In each mode the corresponding operational parameters can be set using the SEL and SET buttons ⇄**image**.

MODE 1 is indicated in the display by a black horizontal bar in the top right corner ⇄**image**.



Note: Unless stated otherwise, operational parameters cannot be changed while the mirror shutter is running.

Overview of Display Modes

	1st display line	2nd display line	Adjustment possibility
Mode 1	Mirror shutter angle or total/take frame counter	Frame rate (fps) or ESU in standby and frame rate (fps) while running (external control connected) or Pr if a program is active	Switch first line display between shutter angle and total/take frame counter.
Mode 2	PS (Programmed frame rate) ESU (external control connected) Current shutter angle if a program is active	Frame rate (Programmed fps) Current frame rate if a program is active	Change programmed frame rate.
Mode 3	Total/take frame counter	Power supply voltage (V)	Toggle 1st display line for mode 1 and mode 3, set low battery warning level (Lobat).
Mode 4 (6)	Async signal enabled (-) or disabled (_) at camera run/stop and volume of the acoustic warning signal	Rotating shutter enabled (-) or disabled (_)	Async signal enable/disable, volume or warning signal, rotating shutter enable/disable.
Mode 5 (7)	Mirror shutter angle Current shutter angle if a program is active	Mirror shutter angle Current shutter angle if a program is active	Set shutter angle.

Note: Mode 1 is displayed after switching on the camera, after pressing the RUN button or 30 seconds after the last operation.

Overview of Display Symbols

Symbol		Meaning
■	continuous	The display is in mode 1.
bat	continuous	Power supply voltage reached warning level.
asy	continuous	Asynchronous operation (camera is not running at set frame rate)
	blinking	Shutter out of Sync
fps	blinking	ESU is connected, but no sync-frequency is available
PROG	continuous	The stored program is activated and can be started while the camera is running by pressing the PROG button.
	blinking	The activated program cannot be run with the set values: Out of range fps or shutter, or battery voltage too low
<∩	blinking	The symbol blinks and the operation control LED glows red: The electronic shutter adjustment is defective.
__o_	in 1st line	Video menu changes being applied (standby).

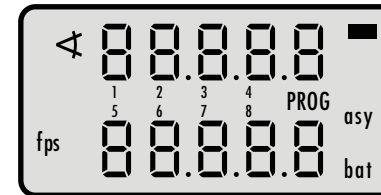

Shutter Angle Display (Mode 1)

It is recommended to set Mode 1 to display the current mirror shutter angle rather than a frame counter value along with the frame rate image. The frame count information does not reflect the exposed, but not the recorded frame count and therefore can be considered less valuable information than the current mirror shutter angle.

- Press the SEL button to toggle between shutter angle and frame counter.
- Within three seconds, press the SET button.



Shutter Angle Measurement

- Holding the PHASE button pressed in standby will run the shutter at approximately 1 fps.
- The display shows the measured angle in the upper line. The lower line displays the power supply voltage.

Note: Shutter angle measurement is not necessary if the angle is permanently displayed in mode 1. Shutter angle measurement only works for mirror shutter angles above 90°.

Locking Camera Controls

- Engage the LOCK switch to prevent unintentional operation of SEL, SET, PROG and the Video Menu button.

Note: If SEL, SET or PROG is pressed while the camera is locked, the display will show "OFF". Note that the LOCK switch also disables the video menu functions on the back of the camera. Locking the camera display has no influence on the phase function, the NORM-PS/CCU switch and on electronic accessories.

9.3. Standard and Programmed Frame Rates

The ARRIFLEX D-21 can be set to run at:

- standard frame rates, (23.976, 24, 25, 29.97, 30, 48, 50, 59.94 and 60 fps^[1]) set in the video menu.
- programmed/variable speeds in increments of 0.001 fps between 1 and 60 fps^[2].

Switching between standard and programmed frame rate is done with the NORM/PS switch ↔**image**. The NORM-position corresponds to the standard frame rate, the PS/CCU-position to the programmed speed.

General Procedure for Changing Frame Rates

- First set a standard frame rate using the video menu (see chapter 7: Camera Configuration).
- Next, set a programmed frame rate using the camera display (see below) or an electronic accessory or program a ramp using an electronic accessory.



Note: The maximum frame rate selectable for programmable speeds and ramps is determined by the standard frame rate set in the video menu. This also applies to the range available for electronic accessories.

Note: Running the camera at speeds other than standard frame rates requires recording equipment that supports variable frame rates. Also see chapter 15: Appendix.

[1] ARRIFLEX D-21 HD can be set to run at standard frame rates of 23.976, 24, 25, 29.97 and 30 fps.

[2] ARRIFLEX D-21 HD is limited to programmed/variable speeds between 1 and 30 fps.

Setting a Programmed Frame Rate (Mode 2)

Note: See General Procedure for Changing Frame Rates.

- Adjust the standard frame rate using the video menu.
- Switch the camera display to mode 2 ⇨ **image** by pressing the MODE button once.
- Press the SEL button repeatedly until the digit to be set blinks.
- Press the SET button repeatedly until the desired value is reached.
- Repeat this procedure until all digits are set to the desired values. A final confirmation of the set frame rate is not necessary.

Note: An internal buffer battery ensures that the programmed frame rate is stored even if the camera is not switched on at the main switch. This battery has a lifetime of approx. 10 years. If the programmed frame rate is not available when the camera is switched on again, the buffer battery has to be replaced by an ARRI service center.



Changing the Frame Rate while the Camera is Running

Note: See General Procedure for Changing Frame Rates.

It is possible to switch between the standard frame rate (NORM) and the programmed frame rate (PS/CCU) while the camera is running by means of the NORM/PS-switch. Changing the frame rate is a mechanical operation, as the rotation speed of the mirror shutter has to be increased/decreased. Therefore changing the frame rate cannot happen instantly.

If the programmed speed has been set prior to changing the standard frame rate (video menu) and exceeds the standard frame rate limit:

- switching the camera to PS/CCU in standby causes the RUN LED to light up red. The camera will not run.
- switching to PS/CCU while the camera is running causes the RUN LED to turn off. The camera will not change its running speed.

Note: Changing the frame rate with the NORM/PS switch while the camera is running creates a basic speed ramp. This operation does not allow automated exposure compensation.

Fine-Tuning the Programmed Frame Rate (PS-Mode)

Note: See General Procedure for Changing Frame Rates.

Fine-tuning of the programmed frame rate can be carried out while the camera is running by means of the buttons SEL (slower) and SET (faster). The setting can be adjusted in increments of 0.001 fps (1.000 to 60.000).

- Set the NORM/PS switch to "PS/CCU".
- Run the camera.
- Press the MODE button once to change to mode 2.
- With the buttons SEL (slower) and SET (faster) change the frame rate.

Note: Fine-tuning the programmed frame rate should always remain below the set standard frame rate to avoid asynchronous operation.

Controlling the Frame Rate Using Electronic Accessories

Note: See General Procedure for Changing Frame Rates.

Depending on the electronic accessory in use, the camera can be controlled:

- with the NORM/PS switch set to NORM, whereas an accessory will replicate the camera display,
- with the switch set to PS/CCU, enabling e.g. variable speeds or exposure compensated ramps using a WRC,
- regardless of the NORM/PS switch position, e.g. when synchronizing the camera to a video signal using an ESU.

Note: With the camera set to NORM, using a programmed speed does not work if it has been set prior to changing the standard frame rate (video menu) and exceeds the standard frame rate limit. The camera will indicate this problem as explained under: Changing the Frame Rate while the Camera is Running.

Note: With the camera set to PS/CCU, using a programmed speed or ramp that exceeds the standard frame rate (video menu) does not work. The electronic accessory will show a corresponding message. More information on operation of electronic accessories can be found in the respective manuals.

Shifting Phase

To capture quartz-synchronized monitors, hold the PHASE button pressed after the camera has run up until the horizontal bar is no longer visible in the viewfinder. The frame rate will increase by 0.2 fps for the duration PHASE is pressed.

Note: Shifting phase causes unsynchronized operation of mirror shutter and HD-SDI output, which may lead to drop frames on recording devices with no variable frame rate support at a certain point. As shifting phase should be required only once before a monitor is captured, it is recommended to first adjust the phase and then record using the standard speeds for HD-SDI output.

9.4. Frame Counter and Battery Information

Frame counter information is not transmitted along with the signal and therefore cannot be used as shot metadata. Two different frame counter types are shown on the camera display in mode 3 and optionally mode 1 ⇄**image**:

- the total amount of exposed frames or
- the take length (amount of frames used in an individual take).

Note: A "t" in the first digit of the upper display line indicates the display of take length (frames).

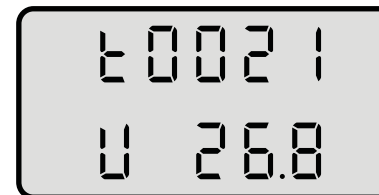

Switching between Display of Frame Counter and Mirror Shutter Angle (Mode 1)

Having mode 1 display the frame rate together with the set mirror shutter angle rather than a frame counter value ⇨ **image** provides a practical overview of the operational camera front end settings. As the frame counter value is not put to use, as when shooting on film, it most likely does not have any relevance.

- In mode 1, press the SEL button to toggle between shutter angle and frame counter.
- Within three seconds, press the SET button.

Setting the Frame Counter Configuration (Mode 3)

To exchange the frame counter type displayed in modes 1 and 3:

- Change from mode 1 to mode 3 by pressing the MODE button twice.
- Press the SEL button; the first digit in the upper display line blinks.
- Within three seconds, press the SET button.

The currently set counting value of mode 3 is displayed. The corresponding counting value optionally shown in mode 1 is automatically altered.

Note: The take length counter is automatically starts from zero each time the mirror shutter is started.



Resetting the Frame Counter (Modes 1 and 3)

- Change to the mode showing the total amount of captured frames by pressing the MODE button repeatedly.
- Press the SET button for at least 3 seconds while in standby to reset the total frame counter.

Displaying the Power Supply Voltage (Mode 3)

Change from mode 1 to mode 3 by pressing the MODE button twice to show the current power supply voltage in the lower line of the camera display.

Setting the low battery warning voltage level (Mode 3)

The voltage levels for the low battery warning shown in camera display and viewfinder can be altered depending on the type of battery in use. To change the voltage level:

- Change from mode 1 to mode 3 by pressing the MODE button twice.
- Press SEL twice to change to the voltage level setting.
- Press the SET button repeatedly until the desired value is reached (values below 20 V cannot be set).
- Repeat this procedure until all digits are set to the desired values. A final confirmation is not necessary.

Note: For NiCd batteries, the voltage level should be set to approximately 22 - 23 V. For Li-ion batteries, a higher value of approximately 26 - 28 V should be used, as these batteries sustain a high voltage level, but then have a steeper discharge characteristic. These are only approximate values as the actual voltage warning level has to be identified by battery type, -age and -capacity and by the desired safety reserve.



9.5. Mirror Shutter Angle and Warning Signal

Enabling/Disabling the Asynchronous Running Warning Signal (Mode 4)

- Change from mode 1 to mode 4 by pressing the MODE button three times.
- Press the SEL button once to access the warning signal settings.
- Within three seconds, press the SET button to select one of the four settings shown in the table below.

Note: Mode 4 actually is Mode 6 based on the ARRI camera display reference structure. Electronic accessories therefore identify it as Mode 6.

Display	Warning signal on start	Warning signal on stop
LS _ _	off	off
LS - _	on	off
LS _ -	off	on
LS --	on	on

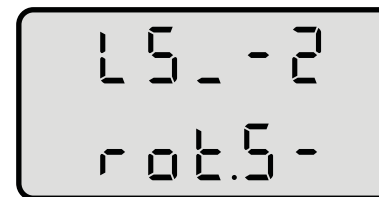

Setting the Volume of the Warning Signal

- Change from mode 1 to mode 4 by pressing the MODE button three times.
- Press the SEL button twice to access the warning signal volume setting.
- Select the desired volume with the SET button (0 = off, 3 = maximum volume)

Enabling/Disabling the Mirror Shutter (Mode 4)

Disabling the mirror shutter parks it, so the sensor is exposed at all times. This effectively extends the exposure time for each frame (see table to the right), but disables the optical viewfinder.

To enable or disable the mirror shutter:

- Change from mode 1 to mode 4 by pressing the MODE button three times.
- Press the SEL button three times to access the mirror shutter enable/disable setting.
- Within three seconds, press the SET button to enable (bar in top position) or disable (bar in bottom position) the mirror shutter.

Note: The resulting exposure time does not double, as the sensor needs to be reset after readout.

Note: At speeds above 29.97 fps, the sensor readout switches from 2880 x 2160 to 2880 x 1620. As a readout of less pixels takes less time, this switch causes a step in the corresponding shutter angle as can be seen in the table to the right.

Note: When the mirror shutter is enabled, it controls the sensor's exposure while the electronic shutter is synchronized for readout in the dark phase. When the mirror shutter is disabled, only the electronic shutter controls the way the sensor is exposed, which causes different motion representation.

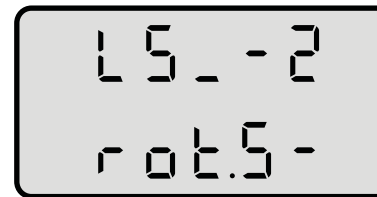

fps	Exposure time [ms] at 180°	Approx. exposure time [ms] shutter disabled	Approx. corresponding shutter angle
1	500	990	356
5	100	190	342
10	50	90	324
15	33	57	306
20	25	40	288
23.976/24	21	32	274
25	20	30	270
29.97/30	17	26	284
35	14	22	272
40	13	18	259
45	11	15	247
48	10	14	239
50	10	13	234
55	9	11	221
59.94/60	8	10	209

Setting the Mirror Shutter Angle (Mode 5)

Without electronic accessories, the following shutter angles can be set using the camera display:

11.2°, 22.5°, 30°, 45°, 60°, 75°, 90°, 105°, 120°, 135°, 144°, 150°, 172.8°, and 180°.

To set the mirror shutter angle:

- Change to mode 5 by pressing the MODE button four times. The display looks like mode 1 without the mode 1 indicator bar in the top right corner.
- Press the SEL button repeatedly until the desired shutter angle appears in the display.
- Within three seconds, confirm the selected shutter angle with the SET button.

Note: If the selected shutter angle is not confirmed within three seconds, the shutter angle will revert to the previously set value.

Using electronic accessories such as the WRC unit, the shutter angle can be set in 0.1° increments in the range of 11.2 – 180°. The procedure is described in the respective instruction manual.

Note: Mode 5 actually is Mode 7 based on the ARRI camera display reference structure. Electronic accessories therefore identify it as Mode 7.



Filming with HMI Light

When shooting scenes with non-electronic ballast HMI or fluorescent lighting, the pulsing light intensity depends on the supply frequency. To achieve constant exposure, the camera's frame rate, the supply frequency of the lighting, and the angle of the mirror shutter must all relate to each other. As the camera frame rate and the supply frequency of the lighting are usually given circumstances, the angle of the mirror shutter has to be used for compensation. The table to the right shows examples for different situations.

Supply frequency	50 Hz		60 Hz	
Frame rate	25 fps	23.976/24 fps	25 fps	23.976/24 fps
Shutter angle	180°	172.8°	150°	180°
Exposure time	1/50th	1/50th	1/60th	1/48th



Always verify the results of these settings with a test shoot!

10. Recording

10.1. Recording Format Setup

Some recording systems are "auto-sensing", which means they can automatically detect the incoming signal format. If this is not the case, the recording format must be set manually to match the camera configuration for frame rate, HD-SDI mode setting (HD444, HD422, Mscope or ARRIRAW) and sometimes the signal range (normal/extended range).

- HD422 outputs a 1080PsF/i 4:2:2 YCbCr signal via single link HD-SDI according to SMPTE 292M.
- HD422 High Speed outputs two 1080PsF/i 4:2:2 YCbCr signals via dual link HD-SDI according to SMPTE 372M.
- HD444 outputs a 1080PsF/i 4:4:4 RGB signal via dual link HD-SDI according to SMPTE 372M.
- Mscope HD422 outputs two 1080PsF/i 4:2:2 YCbCr signals via dual link HD-SDI according to SMPTE 372M.
- ARRIRAW outputs a 2880x2160 or 2880x1620p RAW 12 bit stream mapped into a 4:4:4:4 RGBA signal via dual link HD-SDI according to SMPTE 372M (ARRIRAW T-Link).

Note: Please refer to the recording system's user manual for instructions on the recording format setup.

Note: Also see chapters 7: Camera Output Configuration, 8: Signal Connections and 15: Appendix.



Make sure the format setting on the recording system matches the output configuration of the camera!

10.2. Starting and Stopping the Recording



The Diagnostics menus from the video menu should always be exited before a recording is started.

Depending on the recording device in use, the recording can be started either directly from the camera or by using the recording device's control panel or a connected remote control.

Note: Also see chapter 15: Appendix.

Recording devices with variable frame rate (VariFrame) support:

- Put the camera in standby.
- Set the recording device into record-standby mode with variable frame rate (VariFrame) enabled.
- Running the camera using the RUN button automatically starts the recording.
- Stopping the camera using the RUN button automatically stops the recording.

Note: If variable frame rate (VariFrame) is disabled on the recording device, the recording has to be started and stopped according to the instructions for devices without variable frame rate support. For more information on camera output configuration, wiring instructions and information on variable frame rate (VariFrame), see chapters 7: Camera Configuration, 8: Signal Connections and 15: Appendix.

To display a live camera image on the set monitors without recording the signal:

- Take the recording device out of record-standby mode.
- Put the recording device into EE mode if this does not happen automatically.

Note: Please refer to the recording system's user manual for detailed instructions.

Recording devices without variable frame rate (VariFrame) support:

- Run the camera to provide a live image.
- Start the recording on the recording device or a connected remote control.
- Stop the recording on the recording device or a connected remote control.



*Always stop the camera when no live image is needed (e.g. during shooting breaks)!
This avoids a premature mechanical wear of the mirror shutter and extends the mirror shutter's servicing interval.*

Note: For more information on camera output configuration and wiring instructions, see chapters 7: Camera Configuration and chapter 8: Signal Connections.

11. Functional Expansion Module FEM-2

The ARRIFLEX D-21/HD includes the FEM-2 electronic side cover, which offers the following functions:

- LDS (Lens Data System).
- Motor drivers for up to three CLM-2 motors.
- Two LCS bus interfaces for CLM-1 motors, WHA-2, WHA-3 and ZMU-3.
- LDD (Lens Data Display) interface.
- ACC interface for ESU-1.
- CCU interface (RS 232) for UTM-1 and optional direct WRC-2 connection.
- URM port for optional URM-3 to enable wireless lens- and camera control.



11.1. Lens Data System

The lens data system allows lens- and camera information to be shown on connected Lens Data-Displays. This information includes focus-, iris- and zoom values for any position on the lens ring, the resulting depth of field, fps, shutter and battery voltage. The LDS enables iris compensated speed ramps and delivers precise and reliable information about lens- and camera status for e.g. crane or steadicam setups in wired or wireless configuration. Together with external distance measuring devices (UMT-1 or Cine Tape Measure), it also allows focus tracking.

The LDS is compatible with all lenses equipped with ARRI LDS contacts and lenses using compatible protocols.

The LDS status is indicated by the LDS status LED ↪**image**:

Lens data displays are connected to the LDD socket ↪**image** on top of the FEM-2 module.

- To connect an LDD, use LDD cable K4.55855.0.
- To connect an LDD-FP, use LDD-FP cable K2.54172.0.

Note: Instructions on how to use the lens data displays can be found in the respective instruction manuals.

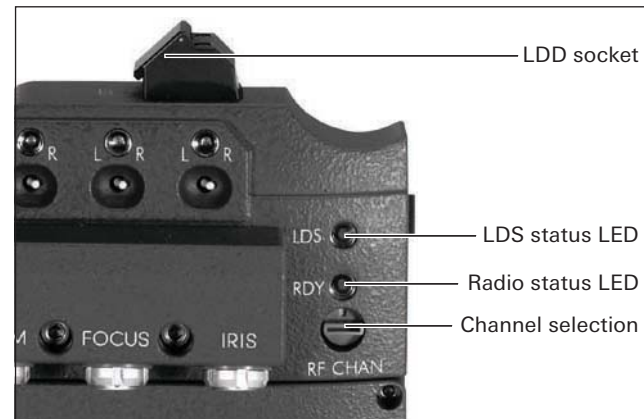

LED	Status
Green	LDS OK
Off	No LDS lens
Red	LDS transfer error

11.2. Wireless System

Equipping the FEM-2 with a URM-3 radio receiver enables wireless communication of lens control and lens data as well as remote control of camera functions.



ARRIFLEX D-21 and D-21 HD use the latest ARRI WRS protocol, denoted by a yellow rubber washer on the antenna. All ARRI WRS products can be upgraded to the new protocol – consult your ARRI Service Center.

Installing the URM-3 radio receiver

Installing an URM-3 radio receiver to the FEM-2 allows wireless communication of positioning information for lenses and remote control of camera functions.



Switch off the camera and disconnect all cables from the camera and FEM-2 before installing the URM-3!



The installation of the URM-3 has to be carried out on a static-free workstation.

- Using a 2.5 mm Allen key, loosen the two screws of the URM port cover.
- Remove the two screws from the holes in the cover.
- Apply the URM-3 to the FEM-2.
- Secure the URM-3 to the FEM-2 using the two screws from the cover.



Only use antennas supplied by ARRI. Do not use directional antennas, omnidirectional antennas or boosters. The RF modem could be damaged and conformance to standards cannot be ensured.

Using the Wireless System

The channel selection switch is used to adjust the correct radio frequency channel for data transfer according to the table to the right. Make sure to set both camera and assigned wireless main unit to the same channel to enable communication.

Note: If two yellow washer remote systems are used on the same set, it is recommended to set one system to an even and the other to an odd channel.



Regional radio guidelines must be observed. Do not use RF channels that are not permitted in your country!

Channel	Frequency	Use
0	2444 – 2472 MHz	Europe except France and Spain. To be used in the USA, Canada, Mexico, New Zealand.
1	2406 – 2345 MHz	Europe except France and Spain. To be used in the USA, Canada, Mexico, New Zealand.
2	2444 – 2472 MHz	Europe except Spain
3	2406 – 2345 MHz	USA, Canada, Mexico, New Zealand, France
4	2444 – 2472 MHz	Japan
5	2406 – 2345 MHz	Australia
6	2444 – 2472 MHz	Australia
7	2406 – 2345 MHz	Spain
8	2444 – 2472 MHz	Corresponds to channel setting 0
9		Radio device deactivated

Changing the radio channel

Use one of the methods described below to set the URM-3 to a radio channel:

- With the camera turned off, set the channel and turn the camera on.
- Set the channel selection switch to 9 (deactivated) and then turn it to the designated channel within half a second.
- To change the channel while the system is active, select the new channel. The RDY LED will light up red, but the wireless will continue to work on the previously set channel until the camera is turned off and on again.

Wireless System Status Indications

The RDY LED of the radio system indicates the status of the radio (see table).

RDY LED	Status
Off	Wireless remote control deactivated (channel 9) or camera deactivated or camera without power
Red/green, alternating	Radio modem initialization in progress. Do not activate wireless main until ready.
Green, blinking	Wireless remote control is ready. Activate wireless main unit.
Green	Wireless remote control OK
Red	Channel selection has been changed while system was active. Turn the camera off and on again to change the channel or reset the channel selection switch to the previously set channel if the change was unintentional.
Red, blinking	Hardware malfunction in the URM radio module. If this error still occurs after restarting the camera, replace the radio module or send FEM-2 including radio module to an ARRI service center.
Green, blinking rapidly	Radio interference. Another URM or FEM-2 is set to the same channel. Select another channel.

11.3. Remote Lens Control

Both CLM-1 and CLM-2 motors can be used with the ARRIFLEX D-21/HD.

- CLM 1 motors should be daisy-chained in series with one of the end motors connected to either (not both) of the LCS bus sockets ⇄**image**.
- CLM 2 motors should be connected to the zoom, focus or iris socket on the CLM-2 plug-in module, according to their position on the lens ⇄**image**.
- CLM-1 and CLM-2 motors may be used simultaneously, but only on different lens axes.

Note: CLM-1 motor function has priority over the CLM-2 motors. If a CLM-1 motor is set to the function zoom, focus or iris and is connected to the FEM-2, the corresponding CLM 2 connection is deactivated.

Each CLM-2 motor connection has a status LED and a direction switch ⇄**image**.

CLM-2 Status Indications

The status for each CLM-2 motor is displayed by its own status LED (see table).

Note: More information on LCS and WRS setups can be found in the FEM-2 instruction manual.

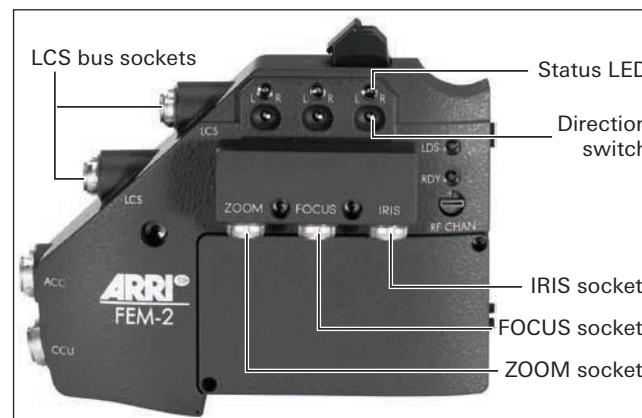

Status LED	Status
Off	No motor connected
Red	Motor connected, remote control not found
Green	Motor OK
Green, blinking	Motor OK, but at an end position
Red, blinking	Motor conflict. CLM-1 assigned to the same function
Red/green, alternating	Motor calibration in progress

11.4. Camera Remote Control

The ARRIFLEX D-21 can be remotely controlled by cable and/or via the wireless remote system. The WRC-2 can control the camera wirelessly (when attached to WMU-3), by cable to the LCS bus (when attached to WHA-2 or WHA-3), or by cable to the CCU socket (direct connection). When connected using the first or second option, the CCU LED on the camera will light up red to indicate that the CCU connector is not available.

Only one camera control unit can be used to control the ARRIFLEX D-21, while more than one WMU-3 can be used in parallel to control lens functions.

Note: More information on LCS and WRS setups can be found in the FEM-2 instruction manual.

Note: For details on how to use the WRC-2, please see the instruction manual supplied with this unit.

The image to the right shows a wired remote control setup with the WRC-2 connected directly to the CCU socket and one CLM-2 motor to allow iris-compensated or shutter & iris-compensated ramps.

Note: If WRC and ESU are used in parallel, the WRC has to use either a wireless connection or the LCD bus.

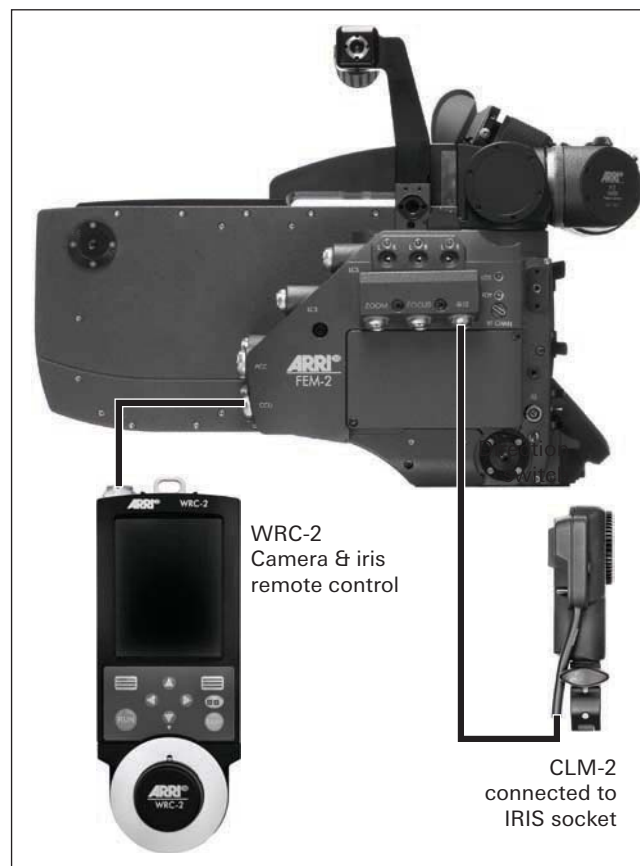

11.5. Compatibility

The ARRIFLEX D-21 components require the following software/firmware versions for proper function:

ARRIFLEX D-21:	SW 1.14, CRC: 65b8c or higher
D-21 HD:	SW 1.14, CRC: 65b8c or higher
E-cover (435):	SW 2.00 or higher, FW 1.07 or higher
FEM-2:	SW 1.34 or higher, FW 0.84 or higher
LDD:	SW 2.82 or higher
LDD-FP:	SW 2.89 or higher



The FEM-2 is only compatible to ARRIFLEX D-21, D-21 HD, 435 Xtreme and 435 Advanced models. Do not attempt to force the FEM-2 onto the ARRIFLEX 435 or 435 ES. This will result in damage to the equipment.



Use only accessories that are compatible with the FEM-2! Accessories not included in the compatibility listing below must not be used. Incompatible accessories or accessories not approved by ARRI could damage the FEM-2, the camera or the accessory itself.

ARRIFLEX D-21 FEM-2 Compatibility List

The following devices are compatible to the ARRIFLEX D-21/HD including the FEM-2 module:

CLM-1	K2.41378.0
CLM-2	K2.52036.0
EXD-1	K2.55013.0
LDD Classic	K2.54012.0
LDD-FP	K2.54163.0
URM-3	K2.52262.0
WHA-2	K2.54079.0
WHA-3	K2.52264.0
WRC-2	K0.60042.0
(via WHA-2 or direct to CCU, only SW 1.1.0 or higher)	
ZMU-3	K2.65003.0

Note: This compatibility list only applies to the ARRIFLEX D-21/HD in conjunction with the FEM-2 module. Information on compatible accessories for the ARRIFLEX 435 Xtreme/Advanced together with the FEM-2 module can be found in the FEM-2 manual.

Note: As new electronic accessories become available for use with the FEM-2, please check the respective manuals for compatibility with the ARRIFLEX D-21/HD.

Incompatible Accessories



Use of the following equipment is not permitted, as it will cause permanent damage to the camera or the FEM-2!

UC-C2 Run Cable	K2.52076.0
LC-S1 Power Cable.....	K4.46859.0
LC-S2 Power Cable.....	K2.47146.0
LC-S3 Power Cable	K2.47147.0
LC-A1 Battery Adapter Cable	K2.41385.0
LC-A2 Battery Adapter Cable.....	K2.41386.0
LC-A3 Battery Adapter Cable.....	K2.44022.0
LC-C1 Run Cable	K2.41398.0
LC-C Run Cable	K2.41399.0

11.6. Replacing the FEM-2

The FEM-2 is part of the ARRIFLEX D 21, D 21 HD and 435 Xtreme and available as an optional expansion for the ARRIFLEX 435 Advanced.



If the FEM-2 module is interchanged between cameras, always make sure that the software and firmware requirements listed above are met!



Switch off the camera and disconnect all cables from the camera and FEM-2 before removing the FEM-2!



This procedure must be carried out on a static-free workstation.

Note: The camera should be securely placed on a stable flat surface or fixed on a pivoting head to provide a secure working environment.

Removing the FEM-2

- Using a 3 mm Allen key, loosen the fastening screw of the FEM-2 electronic side cover ⇨ **image**.
- Pull at the back end of the FEM-2 to remove it from the camera.

Attaching the FEM-2

- Insert both pins on the front of the FEM-2 into the guides on the camera body ⇨ **image**.
- Press the back end of the FEM-2 on the camera to connect the FEM-2 to the camera interface.
- Secure the FEM-2 with its fastening screw.

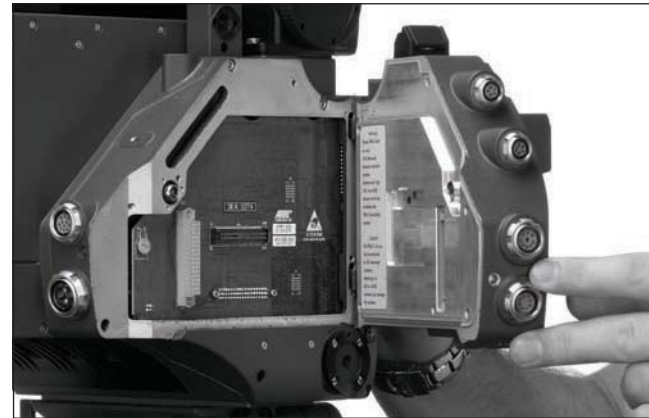
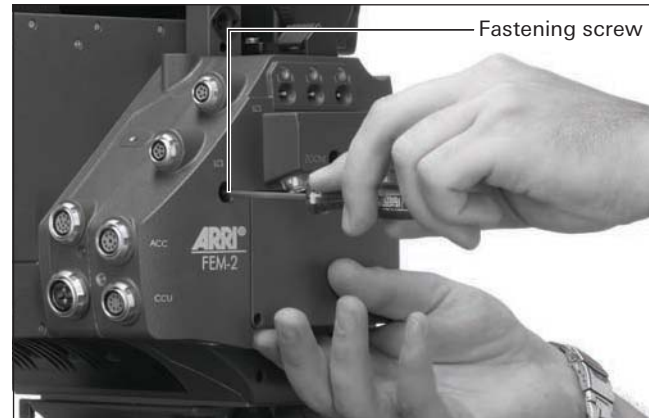
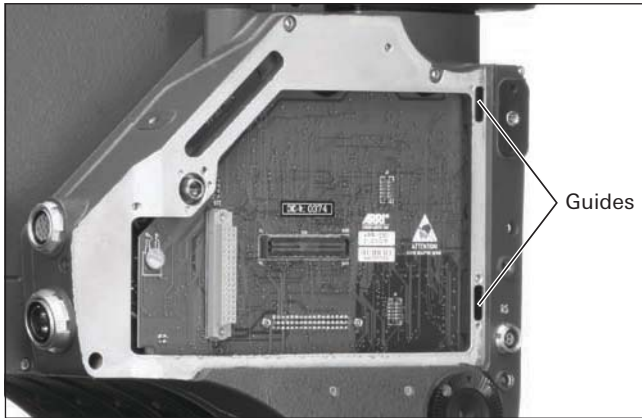

12. Accessories

12.1. External Synchronization Unit ESU-1

The external synchronization unit ESU-1 can be used with the ARRIFLEX D-21/HD, 235, 435 models, 535, 535B, 16SR3/Advanced, 416 models. It allows the camera to be synchronized to other equipment, such as TV monitors.

The unit offers:

- a BNC socket for synchronization of the camera to an external standard video signal (50/60 Hz),
- an RCA socket for synchronization to a pulsed signal (see ESU-1 manual for specifications)
- and an input for an inductive pickup to allow synchronization to a computer or video monitor.

When connected, the camera display shows "ESU" in the upper line. The ESU-1 can be used for frame rates from 3 to 60 fps. The frame rate is indicated on the camera display in Mode 2. The external synchronization unit also provides a phase shifter and a pilot tone generator. The synchronization is retained even when the camera is switched off.

Note: For more information, see TECHN. INFORMATION "External Synchronization Unit ESU-1".



12.2. Flash Mag Mounting Adapter FMA-1

The FMA-1 is used as a docking platform for the Flash Mag HD Mode recorder. It is mounted on the rosettes on the back of the camera and can be rotated about 90° from above to behind the camera. The FMA-1 offers:

- 4:2:2/4:4:4 connection from camera to recorder
- 4:2:2 return signal
- Timecode IN
- 12/24 V IN
- Interface for Flash Mag recorder

To attach the FMA-1 to the camera:

- Tighten the fixed mounting support to the left side rosette on the back of the camera.
- Tighten the articulated mounting support to the right side rosette.
- Connect the 24 V power cable included in the Flash Mag/Sony Fibre Adapter Cable Set (K2.70410.0) to the 24 V RS-socket of the camera and the power input on the FMA-1.
- Use one or both HDTV BNC cables included in the cable set to connect the camera HD-SDI outputs to the FMA-1 HD-SDI inputs.



To mount a Flash Mag on the FMA-1:

- Slide the Flash Mag into the guides of the FMA-1.
- Turn the locking lever to establish a connection and to secure the Flash Mag.
- If the magazine does not power up, the power switch on the lower right side of the FMA-1 has to be turned on.

12.3. Heated Eyecup (HE-4/HE-5)

The heated eyecup prevents the eyepiece from fogging in low temperatures e.g. when filming outdoors in winter. HE-5, in addition, is equipped with an automatic capping shutter that prevents "sensor fogging" when the operator takes the eye away from the eyepiece.

- Pull the regular eyecup off the eyepiece and place the heated eyecup on the eyepiece.
- The connector housing can be rotated, which allows easy mounting on all cameras in all positions.
- Use cable KC-42-SP-S to connect the heated eyecup to the RS-socket.
- Set the heating level with the toggle switch.
"LO": low heat output,
"HI": higher heat output,
"OFF" no heat output.



If the camera and accessories are powered by battery, it is recommended to switch off the eyecup-heating during extended breaks in filming.

Note: The HE-5 cannot be pulled off the eyepiece like HE-4. To unlock its retainer clip, press the button next to the heating level toggle switch.



12.4. Isolating Power Adapter IPA-1

The Isolating Power Adapter provides two 12 V Fischer 11-pin sockets ⇄**image**. The upper socket, labelled '12 V Isolated Power', is intended for powering electronic 12 V video equipment from the camera, e.g. a video/waveform monitor. The adapter ensures electrical isolation of video ground and camera ground to avoid ground loops and potential camera damage. The 11-pin accessory socket is looped through to the lower socket on the adapter.

To use the isolating power adapter:

- Switch off the camera.
- Attach the Power Adapter to the Accessory socket (11 pin Fischer) of the camera E-cover.
- Screw down the mounting bolt of the Power Adapter.
- Connect the video monitor to the video source (camera SD or HD-SDI output) and to the upper socket of the Power Adapter.
- Switch on the camera and the video monitor. When 12 V isolated output is available, the LED on the IPA lights up green.
- If the LED does not light up, make sure that the 12 V supplied by the camera are not overloaded, e.g. by another device that is connected to the lower Accessory socket. The red LED below the Accessory socket on the camera indicates overload.



Only the upper socket supplies 12 V isolated.



The lower socket supplies non-isolated 12 V for standard camera accessories. Using it for video monitors connected to the camera is not recommended.

12.5. Low Mode Support

The low mode support is available in two versions.

- Low mode support (K2.70004.0) improves camera handling on a Steadicam rig and enables underslung use. Consists of a low mode handle, two mounting supports, a short support plate for operation with the viewfinder on the camera and a long support plate and finder cover plate for operation without viewfinder. The finder cover plate offers a take-up for an included set of two 19 mm diameter 80 mm support rods and two 15 mm diameter 145 mm support rods.
- Low mode short set (K2.70010.0) provides a sturdy camera handle with various mounting options for accessories. Consists of a low mode handle, two mounting supports and a short support plate for operation with the viewfinder on the camera.

Note: The short support plate, included in both versions of the low mode support is used to mount the Sony Fibre Interface FLU-1 on top of the camera.

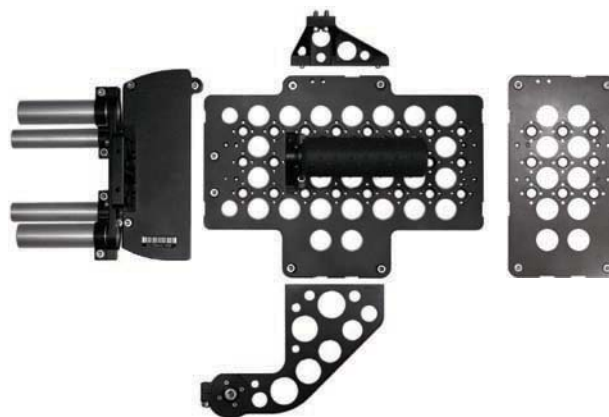

To attach the low mode support:

- Remove the camera grip system as explained in chapter 5: Installation.
- If the camera shall be used without viewfinder, remove the viewfinder system as explained in chapter 6: Optics.



Never operate the camera with an open viewfinder interface!

- Place the low mode support on top of the camera.
- Using a 5 mm Allen key, screw the left side mounting support on the rosette below the ARRIGLOW module.
- Using a 3 mm Allen key, tighten both screws of the right side mounting support on the hand grip attachment point of the camera.
- If the viewfinder has been taken off, the viewfinder interface has to be protected with the finder cover plate. In configuration with the long support plate, the finder cover has to be attached at the front end of the support plate. In configuration with the short plate, the finder cover can be placed on the viewfinder interface by itself. Tighten the three screws of the finder cover plate to the camera.



12.6. Remote Run Switch (RS-4)

The RS-4 has the same functions as the RUN-button on the camera.

- Attach the remote run switch with the spring clamp (e.g. to the pan handle).
- Plug the RS-4 plug into the RS-socket.



12.7. RS-Socket Distributor (24 V Plug-on module)

The 24 V plug-on module provides an additional RUN-button to facilitate operating the camera from the right side and two RS-sockets for connecting 24 V accessories. The module is mounted on the right side of the camera in front of the electronic cover.

- To attach the 24 V plug-on module, plug its connector into the RS-socket.
- Tighten the fastening screw.

Note: When a UMC-3 radio modem is attached to the FEM-2 electronic side cover, the antenna socket of the radio module will block access to one of the RS-sockets of the 24 V plug on module.



The RS-sockets supply the same voltage as the camera power supply. Voltages over 32V will be limited to 32V. Ensure that the accessories to be used are suited for the available voltage!

The camera provides a total power output of 72 watts on the 24 V sockets.

At 24 V, this results in 3A maximum continuous current and 5A peak load.

At 32 V, the maximum allowable continuous current is 2A.



Ensure that the accessories to be used are suited to the available voltage and that the connected accessories do not overload the camera's power outlets.

12.8. Shoulder Set S-5

The shoulder set S-5 allows switching the camera from tripod to shoulder without having to remove the optical accessories. Available set and components:

Shoulder Set S-5 complete (K0.70410.0) 

With left and right grips including run/stop switch and ergonomically shaped shoulder pad for D-21.

Shoulder Set S-5 (K2.70450.0)

With left and right grips including run/stop switch

Shoulder Pad for D-21 (K2.70011.0)

Ergonomically shaped shoulder pad for D-21.

Note: The S-5 can be used with all other ARRIFLEX shoulder pads.

To attach the shoulder set to bridge plate BP-8 or BP-9:

- Screw the shoulder pad to the back of the shoulder set.
- Slide the shoulder set from the rear into the dovetail guide of the bridge plate as far as it will go. A latch pin will automatically keep the shoulder set in the correct position.
- Clamp the shoulder set using the bridge plate clamping lever.
- Plug the cable for the remote RUN button into the camera's RS-socket.
- Check that the shoulder set is firmly seated on the camera.



To detach the shoulder set:

- Open the clamping lever on the bridge plate.
- Pull the latch pin on the bottom of the shoulder set and slide the shoulder set backwards and out of the bridge plate's dovetail guide.

12.9. Fiber Link Unit FLU-1

The FLU-1 enables a single fibre cable to carry 4:4:4 or 4:2:2 HD signals from the camera to a separate recorder along with a 4:2:2 HD monitoring signal back from the recorder to the camera and remote control of the basic recorder functions (record start/stop and tally). The cable can measure up to 500 meters/0.3 miles in length and uses industry standard fibre connectors. The link unit enables shooting at up to 59.94 fps with the D-21^[1] and the Sony HDCAM SR field recorder or other suitable HD recorders.

To use the FLU-1 on the camera:

- Attach the low mode short set, as described above.
- Attach the FLU-1 at the rear end of the short support plate .
- Connect the 24 V power cable included in the Flash Mag/Sony Fibre Adapter Cable Set (K2.70410.0) to the 24 V RS-socket of the camera and the power input on the FLU-1.
- Connect both HD-SDI outputs from the designated HD-SDI output board to the corresponding HD-SDI inputs on the FLU-1.
- Connect the SMPTE fibre cable to FLU-1 and recorder.

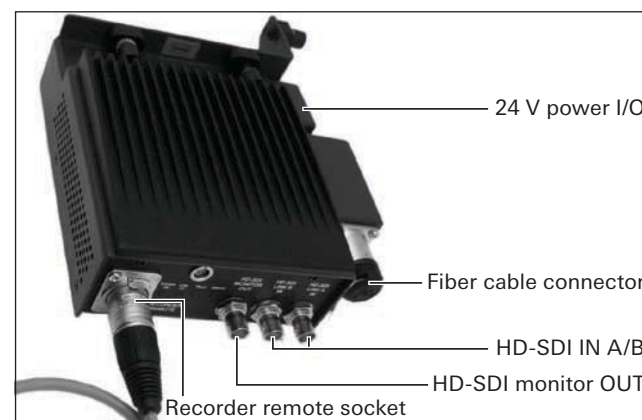

Note: Follow the instructions to set the camera output configuration, as described in chapter 7 Camera Configuration. Using the FLU-1 requires no additional setup.

Note: See the HD recorder instruction manual for instructions on setting up the corresponding HD format using the fibre input.

[1] ARRIFLEX D-21 HD can output up to 30 fps.

Fiber Link Remote FLR-1

The FLR-1 allows control of the record and review functions of a Sony SRW-1/SRPC-1 field recorder from the camera over the fibre cable. The remote has LEDs for tally (green LED) and recorder ready (blue LED).

To use the FLR-1 remote:

- Connect the FLR-1 to the RECORDER REMOTE socket on the FLU-1.
- Set the Sony field recorder to record-pause mode. The ready LED lights up blue when the recorder is ready for recording.
- Setting the recording switch to REC starts the recording. The tally light will light up green when the recorder is running.
- Setting the recording switch to PAUSE puts the recorder into record-pause.
- Pressing the blue REVW button will play back the last few seconds from the HDCAM SR tape and afterwards put the recorder into record-pause again. The ready LED lights up blue when the recorder is ready for recording.



Using the FLU-1/FLR-1 additionally requires:

- Sony SRW-1/SRPC-1 field recorder with the HKSR-101 fibre optic adapter or another suitable HD recorder.
- Variable frame rate recording with the Sony field recorder requires the HKSR-102 cache board.
- Low mode short set (K2.70010.0).
- Flash Mag/Sony Fibre Interface Cable Set (K2.70410.0) for power and signal from camera.
- Fibre Optic Cable 30 m/100 ft (K2.70500.0) or 100 m/330 ft (K2.70501.0) for signal connection to the recorder.



Accessories

12.10. Wireless Remote Control WRC-2^[2]

The WRC-2 is a modern and user-friendly remote control and program unit for all new-generation ARRIFLEX and ARRICAM cameras. It combines the functionality of the RCU-1 and WRC-1. Beyond that, the WRC-2 provides unique new features and due to the touch screen user interface, remote controlling a camera was never faster and easier.

The range of functions is automatically adapted to the attached camera. Since the functionality of the unit is software based and therefore expandable, the WRC-2 is the most flexible remote control unit, ARRI has ever provided.

The WRC-2 enables the user to remotely control the camera speed, the shutter angle of the mirror shutter and the aperture of the lens (iris) when used together with FEM-2 and a CLM-1 or CLM-2 motor, providing a wide range of compensation options for constant exposure.

Note: More information on variable speeds/ramping can be found in chapter 15: Appendix.

Note: For more information and operation instructions, see chapter 11: FEM-2 and the WRC-2 manual.



[2] Ramps/variable speeds, custom frame rates with or without iris and/or shutter compensation are not available when connected used with an ARRIFLEX D-21 HD.

12.11. Work Light

- The work light can be turned on and off with the ring on the lamp head.
- The brightness of the work light can be adjusted with the mechanical aperture.

To attach the work light to the camera:

- Attach the dovetail-adapter to the hand grip using the screw.
- Slide the work light into the dovetail-guide and clamp.
- Connect the plug to the RS-socket.



12.12. General Note

Note: For further information on the accessories, please refer to the corresponding instruction manual.

13. Camera Care

13.1. General Information

When maintaining and cleaning the camera and accessories, pay careful attention to the following notes and tips:

- Camera and accessories should be placed on a stable, flat and clean surface that is covered with foam material or clean, lint-free cloth.
- For cleaning, it is recommended to use soft, lint-free cloths and swabs. Also suitable are special cleaning tissues and small sponges as used in cleaning computers and video equipment.



Under no circumstances use acetone or nitro-thinner! These chemicals dissolve paint and damage highly polished surfaces.



Disconnect the camera from the power supply and other connecting cables whenever power or signal connections are not required.



Working on the imager and attaching or detaching electronic accessories has to be carried out on a static-free workstation.

13.2. Imager Check

A film camera exchanges its “sensor” – i.e. the piece of film negative holding a frame – after a single exposure. The sensor of a digital camera is used for countless exposures and generally remains in its place unless it is damaged and replaced. It is therefore recommended to perform an imager check prior to or at the end of each day of shooting to ensure the camera’s imager has not taken any mechanical or electrical damage.

Imager Surface

The camera's sensor and optical filters are located behind a protective cover glass (filter). This cover glass can be replaced in case it is damaged. Nevertheless, opening the lens compartment should always be done with care to avoid mechanical damage to the mirror shutter, the sensor cover glass and the sensor.



Before removing a lens, always make sure to stop the mirror shutter. This not only prevents damage to the shutter when a wrong lens (e.g. 16 format lens) is inserted by mistake. The shutter in "finder-open" position acts also as a protective cover to the imager.

Dust Check

The sophisticated design principle of the camera's optical module delivers outstanding images with cinematic look and feel, but also makes the imager sensitive to contamination. Dust particles that have settled on the sensor cover glass during a lens change may become visible as dark spots in the output image, similar to lint leaving marks on exposed film. The degree of this effect depends on the aperture of the lens and can be completely eliminated by regular dust checks.

Dust Check Looking at the Imager Surface

- The camera has to be in standby with the mirror shutter not running.
- If the mirror shutter is in front of the sensor, briefly press the PHASE button to rotate it out of view.
- Turn the camera off using the main switch and disconnect the power cable to avoid accidental operation of the RUN button or electrical discharge.
- Use a bright flashlight to illuminate and check the sensor cover glass for dust.

Note: Looking at the imager using a magnifying glass makes checking for dust easier.



Do not use a magnifying glass if sunlight is used for illumination, as focused sunlight can cause permanent damage to the sensor!

Dust Check using the HD output

- Attach a lens and set the focus to infinity.
- Put a diffuse white glass plate in front of the lens.
- Point the camera towards a light source.
- Start the camera to get a live signal on an attached HD display.
- Shut down the iris between 11 and 22, depending on the brightness of the light source the camera is pointed at.

Dust on the sensor cover glass will show on the monitor as dark spots. If dust can be seen in the HD output, remember that the image projected on the sensor is rotated by 180°.

Note: Alternatively you can point the camera at an evenly lit surface or at the sky.



Do not point the camera towards the sun, as focused sunlight can cause permanent damage to the sensor!

Mechanical Damage to Imager Surface

If the cover glass of the sensor has been scratched or punctured, it can be replaced by an ARRI service center.

Cleaning the Sensor Cover Glass

The sensor surface should only be cleaned with a blower bulb  or brushed off with a clean optical brush. If the sensor surface has been contaminated by solid dirt or grease, special optical cleaning kits should be used for removal.



NEVER CLEAN AN OPTICAL BRUSH WITH FINGERS!

This will cause the bristles absorb grease and leave streaks on the sensor surface.



NEVER USE METHANOL OR ACETONE TO CLEAN THE SENSOR SURFACE!

These chemicals will irrecoverably damage the sensor cover glass surface.



NEVER USE CANS WITH COMPRESSED AIR OR GAS TO BLOW OFF THE DUST!

Gas and Fluid is very cold when it exits the container and can permanently damage the sensor's surface.

Note: Using compressed air to blow dust off may also damage the mirror shutter surface. Furthermore, this may lead to a static electricity charge on the sensor's surface, which causes the sensor to attract dust.



Condensation

When moving the camera from a cool to a warm location or when the camera is used in a damp climate, condensation may form inside the lens compartment, on the sensor cover glass and on the electrical connections.



Operating the camera in this state may cause a failure or even permanent damage.

To reduce the risk of condensation:

- Attach the included air-drying cartridge to the PL-Mount of the camera when the camera is stored in an environment that is cooler than the location the camera will be used at.
- In ambient temperatures above 30 °C/86 °F and/or humidity above 60%, always attach the drying cartridge to the PL-Mount of the camera, whenever the camera is not used. This not only applies to storage, but also to shooting breaks and situations when the camera remains without a lens attached for an extended time.



When the ARRIFLEX D-21 is transported or stored inside a transport case, the air-drying cartridge has to be removed.

Pixel Failure

ARRI Imaging Technology (AIT) inside the D-21 & D-21 HD provides an automated Defect Pixel Correction (DPC), which instantly identifies a pixel failure and corrects it with information gathered from the surrounding pixels. This correction is not visible as the number of dead/defective pixels typically accounts for a very small fraction of the total pixel count.

The probability of a cluster of adjacent pixels failing is very low in comparison to a single pixel becoming defective. DPC corrects failing pixel cluster based on a dead/defective pixel map.

Checking for Pixel Failure Clusters

Despite the low probability of its occurrence, it is recommended to check for cluster pixel failures at the end of each shooting day or prior to shooting. A cluster of defective/dead pixels is relatively easy to spot in the output image.

Defective pixels deliver improper luminance values causing pixels bright red, green or blue spots in the output image.

Dead Pixels deliver no signal at all causing dark spots or spots with a green or cyan color cast in the output image.

To check for defective and dead pixels:

- Connect the camera signal output (HD-SDI output) to a suitable HD display.
- Start the mirror shutter if it is not running.
- Put a lens cap on the camera lens.
- Set the contrast characteristic (video menu) to the highest EI value.
- If no colored bright pixels appear, take the lens cap off.
- Point the camera at a homogeneously lit, neutral grey surface that covers the full output image and defocus the lens or put a diffuse white glass plate in front of the lens and point the camera into a light source.
- Adjust iris or lighting so the output video level reaches 40 to 50% on a connected waveform monitor or in the RGB-Histogram from the OSD Tools.
- If no colored bright pixels appear, set the contrast characteristic (video menu) to an EI value of 250.
- With the camera still pointing at the same target, adjust iris or lighting so the output video level reaches 60 to 70% on a connected waveform monitor or the OSD RGB-Histogram.
- If no dark pixels or spots with a green color cast appear, the camera is ready for shooting.
- If defective or dead pixels do appear, the camera's defective/dead pixel map has to be updated.

Note: When checking for cluster pixel failures, it is recommended to use a display providing a pixel-to-pixel output. When the full 4:3 sensor aperture is used, short sequences should be captured and processed for each step to provide a pixel-to-pixel display of the camera's output. Using the preview output of an ARRIRAW T-Link certified recorder is a possible option, but may not allow identification of very small cluster pixel failures.

Note: Updating the camera's defective/dead pixel map can be carried out on location by a trained D-21 service technician, in an ARRI service center or at an ARRI rental facility. This procedure takes about 20 to 30 minutes, whereas in postproduction, removal of dead pixels can be a lengthy process depending on the image content. It is therefore highly recommended to take care of dead and defective pixels right away instead of fixing them in postproduction.

13.3. Cleaning the Field Lens

- If the mirror shutter is in front of the imager, briefly press the PHASE button. The shutter is positioned to protect the mirror surface from damage as far as possible.
- Before cleaning the field lens, switch the camera's main switch off and disconnect the camera from the power supply!
- Remove the lens or the protective cap.
- Do not touch the sensor or the mirror surface!
- Using the special forceps (Hirschmann clamp) from the camera's toolkit, pull the ground glass out of the holder by its tongue.
- Using the special forceps, first lift the field lens upwards by its tongue then pull it out of its holder.
- Clean the field lens with a dry, lint-free cloth.
- Check that ground glass and field lens to be inserted are completely clean.
- Using the special forceps, push the field lens into the holder as far as it will go. The red marker point must be on the left looking into the camera lens compartment. A ball catch fixes the field lens in the correct position.
- Check that the field lens is locked in place.



- With the special forceps, push the chosen ground glass into the holder as far as it will go. The red marker point must be on the left looking into the camera lens compartment. A ball catch fixes the ground glass exactly in the right position.
- Check that the ground glass is correctly locked in place.

14. Technical Data - ARRIFLEX D-21 & D-21 HD

Lens mount	54 mm PL mount, centered for Super 35, with Lens Data System contacts (LDS) flange focal depth 52.00 mm nominal
Display	Camera display on left side with individual buttons for: camera RUN, PHASE, NORM-PS/CCU control, LOCK, MODE, SEL and SET. Video menu over composite video output for control of operational parameters: output mode, standard frame rate, white balance and color matrix, signal output range, contrast characteristic and sensitivity.
Shutter	Spinning, electronically adjustable reflex mirror shutter adjustable to 11.2°, 22.5°, 30°, 45°, 60°, 75°, 90°, 105°, 120°, 135°, 144°, 150°, 172.8° and 180°
Viewfinder	Optical reflex viewfinder with interchangeable ground glass; Spherical or universal (adjustable to spherical or anamorphic) viewfinder available. Viewfinders are adjustable in two axes with automatic or manual image compensation, laterally extendable for left eye operation and show illuminated frame lines (ARRIGLOW, adjustable in brightness). Optional medium or long finder extender including magnifier. Optional heated eyecup.
Video assist	SD monitoring (PAL/NTSC video downscaled from captured image) with composite video or S-Video outputs
Recording	HD recording devices supporting HD-SDI (SMPTE 292M) or dual link HD-SDI (SMPTE 372M) signals for HD Mode operation
Common connections	2x composite video out (CVBS), 1x S-Video out (Y/C) 1x power in (BAT) 1x 12 V accessory power out (Fisher 11-pin) 1x 24 V accessory power out (RS) 1x lens data display (LDD) 2x lens control system bus (LCS) 1x accessory interface (ACC) 1x camera control unit (CCU) 1 each focus, iris, zoom for lens motors

Common Technical Data

Power	24 V DC (acceptable voltage range: 20.5 to 36 V DC) Power consumption @ 24 fps: less than 3.15 A (depending on output configuration) Power consumption in Standby: less than 2.25 A
Sound	Less than 20 dB(A) @ 24 fps
Dimensions	Length: 39 cm/15.35" Width (viewfinder left): 27 cm/10.83" Height with handle: 30 cm/11.81" Height without handle: 23 cm/9.06"
Temperature Range	0 to 40 °C or 32 to 104 °F
Accessories	Accepts the whole range of ARRI matte boxes (15 or 19 mm rods), follow focus and ARRI electronic accessories, Lens Control System (LCS), Lens Data System (LDS), Wireless Remote System (WRS), Wireless Remote Control (WRC-2), Iris Control Unit for speed/iris ramps (ICU-1), Remote On/Off Switch (RS-4), External Synchronization Unit (ESU-1). Specifically for ARRIFLEX D-21/D-21 HD: Low mode support set for Steadicam operation or underslung use and top-mounting of accessories without bridge plate, Flash Mag Mounting Adapter (FMA-1), Fiber Link Unit (FLU-1) and Fiber Link Remote (FLR-1) for an optical link to the recorder.
Misc.	Extra attachment points for rigging

14.1. Technical Data - ARRIFLEX D-21

Output interface	2x dual link HD-SDI
Frame rate	<p>1 - 60 fps in HD Mode HD422 (16:9)</p> <p>1 - 30 fps in HD Mode HD444 & Data Mode (16:9)</p> <p>1 - 25 fps in HD Mode Mscope™ & Data Mode (4:3)</p> <p>Frame rates other than the standard frame rates of 23.976, 24, 25, 29.97, 30, 48, 50, 59.94 and 60 PsF can be achieved with a recorder that interprets the VariFrame Flag. All speeds crystal and can be set with 0.001 fps precision. Does not run in reverse.</p>
Aperture	<p>23.760 x 13.365 mm/0.9354" x 0.5262" in HD Mode</p> <p>23.760 x 17.820 mm/0.9354" x 0.7016" max. in Data Mode & Mscope™</p>
Signal output	<p>HD Mode – HD-SDI (SMPTE 292M):</p> <p>- 1920 x 1080 4:2:2 YCbCr 10 bit @ 23.976, 24, 25, 29.97, 30PsF</p> <p>HD Mode – dual link HD-SDI (SMPTE 372M):</p> <p>- 1920 x 1080 4:2:2 YCbCr 10 bit @ 48, 50, 59.94, 60PsF</p> <p>- 1920 x 1080 4:4:4 RGB/YCbCr 10 bit @ 23.976, 24, 25, 29.97, 30PsF</p> <p>Mscope™ – dual link HD-SDI (SMPTE 372M):</p> <p>- 1920 x 1080 4:2:2 YCbCr 10 bit @ 23.967, 24, 25 PsF</p> <p>Data Mode – ARRIRAW T-Link (ARRIRAW transmission protocol mapped in RGBA HD-SDI stream according to SMPTE 372M):</p> <p>- 2880 x 2160 RAW 12bit Bayer data @ 23.976, 24, 25p</p> <p>- 2880 x 1620 RAW 12bit Bayer data @ 29.97, 30p</p>
Recording	Data Mode requires ARRIRAW T-Link certified or compatible recording devices
Weight	<p>Body only: 8.7 kg/19.2 lbs</p> <p>Body and viewfinder: 11.0 kg/24.3 lbs</p>

14.2. Technical Data - ARRIFLEX D-21 HD

Output interface	1x dual link HD-SDI
Frame rate	1 - 30 fps in HD Mode HD422 & HD444 (16:9) 1 - 25 fps in HD Mode Mscope™ (4:3) Frame rates other than the standard frame rates of 23.976, 24, 25, 29.97 and 30 PsF can be achieved with a recorder that interprets the VariFrame Flag. All speeds crystal and can be set with 0.001 fps precision. Does not run in reverse.
Aperture	23.760 x 13.365 mm/0.9354" x 0.5262" in HD Mode 23.760 x 17.820 mm/0.9354" x 0.7016" in Mscope™
Signal output	HD Mode – HD-SDI (SMPTE 292M): - 1920 x 1080 4:2:2 YCbCr 10 bit @ 23.976, 24, 25, 29.97, 30PsF HD Mode – dual link HD-SDI (SMPTE 372M): - 1920 x 1080 4:4:4 RGB/YCbCr 10 bit @ 23.976, 24, 25, 29.97, 30PsF Mscope™ – dual link HD-SDI (SMPTE 372M): - 1920 x 1080 4:2:2 YCbCr 10 bit @ 23.967, 24, 25 PsF
Weight	Body only: 8.6 kg/19.0 lbs Body and viewfinder: 10.9 kg/24.0 lbs

15. Appendix

15.1. Troubleshooting

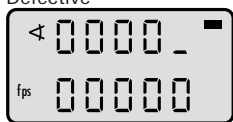
<i>Operation</i>		
Problem	Possible Cause	Remedy
Blown fuse	12 V or 24 V output overload.	Camera is equipped with self-resetting thermal fuses. To reset, disconnect all accessories and wait for one minute.
Camera Display: Monitoring Defective 	Fault in the electronic control of the mirror shutter drive system.	CAUTION: May result in faulty exposure! Warning can be overridden by switching camera's main switch off and on. If "Monitoring Defective" is overridden, additional faults in electronic control of drive system will not be detected.
Camera won't start in low temperatures.	Camera may not start/run unstable in ambient temperatures below 0 °C/32 °F.	ARRI or its subsidiaries do not assume responsibility for damage if camera is operated outside specified operating temperature range. Turn on camera at least an hour before shooting with ambient temperature not lower than 0 °C/32 °F. Then take heated camera outside. Cover camera with a blanket if necessary.
Diagnostics LED red.	One or more system checks failed.	Restart camera. Perform standard reset and restart camera. Take camera to ARRI service center if problem persists.
Flash Mag does not turn on when connected to Flash Mag Mounting Adapter FMA-1.	Flash Mag Adapter not turned on.	Power on Flash Mag Adapter using power switch on left side of adapter.
No access to camera control functions or video menu.	LOCK switch engaged.	Disengage LOCK switch above camera left side display.

Operation		
Problem	Possible Cause	Remedy
On screen menu is hardly readable or does not appear.	Camera set to RUN or video menu accessed before all imaging diagnostics LEDs light up green.	Do not operate camera before all 3 status LEDs below the video menu button on the back light up green. If video menu is visible, toggle the SD output format (NTSC/PAL and back) or restart camera and wait until status LEDs light up green.
Power LED red, blinking. Camera does not operate.	Standard reset performed.	Restart camera to complete standard reset.
Power LED red.	Problem with internal power supply.	Restart camera. Perform standard reset and restart camera. Take camera to ARRI service center if problem persists.
Shutter angle measurement does not work using PHASE button in standby.	Mirror shutter angle set below 90°.	Shutter angle measurement using PHASE button only works for shutter angles above 90°. Set mode 1 to permanently display shutter angle.
Speed ramp does not work. RUN LED is off.	Maximum ramp speed exceeds standard frame rate set in video menu.	Adjust standard frame rate (video menu) to frame rate higher than or equal to programmed or maximum ramp speed.
Temperature LED off.	Slight sensor temperature deviation from nominal level.	Turn camera off and wait 5 minutes before turning it back on. Make sure that air can flow through the ventilation shafts at the back of the camera body.
Temperature LED red.	Sensor temperature deviation from nominal level above acceptable limit. Possible malfunction of internal cooling system.	Turn camera off and wait 5 minutes before turning it back on. Make sure that air can flow through the ventilation shafts at the back of the camera body. Take camera to ARRI service center if problem persists.

Optics		
Problem	Possible Cause	Remedy
Condensation on the sensor cover glass.	When camera is moved from a cool to a warm location or when used in damp climate, condensation may form inside the lens compartment, on the sensor and on the electrical connections.	Put camera in interim storage at temperature close to ambient temperature during shooting. Attach air-drying cartridge to PL-Mount during storage in an environment that is cooler than the shooting location. In ambient temperatures above 30 °C/86 °F and/or humidity above 60%, always attach air-drying cartridge to PL-Mount whenever camera is not in use. This applies to storage (outside transport case) shooting breaks and situations when no lens is attached to camera for an extended time.
Ground glass alignment is off.	Ground glass shifted during transport.	Open lens compartment and check that ground glass is correctly inserted into ground glass holder.
Image is shifting when using a zoom lens.	PL-mount not set to Super 35.	The D-21 PL-mount has to remain in Super 35 position (2) at all times.
Viewfinder image is all red.	No ARRIGLOW mask inserted.	Insert glow mask matching the ground glass or turn off ARRIGLOW.
Viewfinder image is upside down.	Image orientation not adjusted after finder extender was attached/detached.	Press locking key on far right of viewfinder arm and turn rotation adjustment knob until it locks in next position.
Viewfinder shows no image when mirror shutter is stopped or camera is off.	Mirror shutter not in viewing position.	Turn on camera and press PHASE button. Mirror shutter always returns to last position it was set to.

Output		
Problem	Possible Cause	Remedy
ARRIRAW output shows no image/strange image on recording or connected HD display.	Recording system not compatible to ARRIRAW T-Link. HD display cannot display ARRIRAW directly.	ARRIRAW/data mode output can be recorded using ARRIRAW T-Link certified recorders or recorders supporting 4:4:4:4 RGBA HD-SDI streams according to SMPTE 372M. Recorders without ARRIRAW T-Link certificate may offer limited or no preview options.
	Inverted cable connection or problem with standard frame rate setting.	Make sure cables are correctly connected: HD-SDI link A to recorder input A or 1 same output board link B to recorder input B or 2
Automatic white balance produces a color cast.	Target used for automatic white balance was not evenly lit or shows color cast.	Make sure target used for automatic white balance is evenly lit and does not reflect colors from surrounding objects.
Camera HD-SDI output is black, shows a freeze frame or vertical stripe pattern. SD output OK, or also showing vertical stripe pattern.	Camera boot problem or HD-SDI output cannot be synced to connected display or recording system.	Change standard frame rate (video menu) to other setting and back again. If the problem persists, restart camera. Wait until all status LEDs on back of camera turn green before running the camera. Perform standard reset and restart camera. If issue cannot be resolved, take camera to ARRI service center.
Camera HD-SDI output shows a raised noise level or is offset to the side, or output freezes in high temperatures.	Camera may overheat in ambient temperatures above 40 °C/104 °F. "Temp" LED off means a slight sensor temperature deviation. "Temp" LED red means sensor temperature deviation above acceptable limit.	ARRI or its subsidiaries do not assume responsibility for damage if camera is operated outside specified operating temperature range. Turn camera off for 5 minutes to let system cool down. Ensure airflow through ventilation shafts at the back of the camera body. If camera is used in vertical position (pointed towards floor or ceiling) tilt it back to horizontal position between takes to allow better cooling. Use accessory fan to increase airflow through vent shafts.
Camera signal has dropouts.	If camera display shows "BAT" warning, the power supply voltage is insufficient.	When on mains power, make sure the camera power supply voltage set to 24 V (26 V). When using batteries, check battery voltage level. If below 20.5 V, replace battery.

Output		
Problem	Possible Cause	Remedy
Camera signal has dropouts.	Maximum length of signal cable exceeded.	Use shorter signal cable. Recommended maximum length for HDTV BNC cable is 40 m/130 ft. Recommended maximum length for fibre cable is 0.5 km/0.3 mi.
	Signal cable or cable connection damaged.	Check signal cable at connectors and along entire length. If cables or connectors show damage, replace immediately.
Camera Zebra does not work when using log contrast characteristics.	Log characteristics do not use the full signal level range.	Point the camera towards a bright surface so it produces clipping and adjust the zebra level to this maximum output level.
Dark spot(s) in output image.	Dust, liquid or solid dirt on sensor or back of lens.	Make sure mirror shutter is not running! Perform dust check and clean sensor cover glass. NEVER USE METHANOL, ACETONE OR DUST OFF/COMPRESSED AIR TO REMOVE DUST! Only change lenses in a dry and dust-free environment. Use protective cap when no lens is attached to camera. If contamination cannot be removed on location, opening the iris reduces the visibility of spots. If cover glass has been damaged, take camera to an ARRI service center for repair.
Defective/dead pixel clusters in output image.	Temporal or permanent failure of sensor photocell cluster due to air transportation, vibration, mechanical shocks or after electrical connections.	Groups of defective/dead pixels should be immediately taken care of with an updated dead pixel mask, as removal in postproduction is a costly procedure. Updating the dead pixel mask should only be performed by trained service technicians or an ARRI service center.
High noise level or offset in output image when using log C or log F contrast characteristics.	Material captured with log characteristics requires adapted viewing equipment.	For correct viewing on HD displays or in digital projection a log/lin conversion LUT (log C) or Filmstream™/lin conversion LUT (log F) must be applied to the signal. Preview LUTs available in editing software, via dedicated hardware linked between playback and display device, or as integrated hardware in some display devices.

Output		
Problem	Possible Cause	Remedy
Order of frames is swapped when recording ramps or frame rates > 30 fps.	Inverted cable connection.	Make sure cables are correctly connected:
		HD-SDI 1 link A to recorder input A or 1
	HD-SDI 2 link A to recorder input B or 2	
	Problem with standard frame rate setting.	Repeat standard frame rate setting (video menu). Check that frame swap has been resolved by recording a short test sequence.



15.2. Glossary

Clipping

In digital cameras, clipping is an effect resulting from too much over- or underexposure. Overexposing a sensor pushes bright image areas into full saturation, resulting in nothing but white image areas. Underexposure of a sensor leaves dark image areas below the noise floor resulting in black image areas.

Color Signals and Chroma (Sub-)Sampling

RGB, YUV, 4:4:4 and 4:2:2 are terms often used for digital video. While RGB and YCbCr (correct denotation for the digital component signal often called YUV) represent different forms of color signals, 4:4:4 and 4:2:2 are a denotation for chroma sampling.

Color Signals

- RGB means an analogue or digital form of signals for the three color components red, green and blue. RGB signals deliver very high quality images providing high creative freedom for postproduction. At the same time RGB signals require high bandwidth and storage space.
- YCbCr is a component signal consisting of a luma channel (luminance) and two chroma channels (color difference channels). These components are calculated from an RGB signal. YCbCr signals require less bandwidth than RGB signals and thus are more common for economical reasons.

Chroma (Sub-)Sampling

The bandwidth required by component signals can be further reduced by chroma subsampling. The idea behind this technique utilizes human vision. A reduction of color information has lesser influence on the impression of an image, as long as full luminance information is available. For this reason, the chroma channels of a component signal may be sampled with a lower frequency than the luma channel – i.e. subsampling.

The notation of three or sometimes four digits separated by colons represents the relationship of subsampling.

- The first digit represents the relative horizontal sampling frequency of the luma channel. (simply speaking: the amount of information per line) “4” is just a historical reference to standard definition television and provides a base value.
- The second digit represents the horizontal subsampling factor of the chroma channels (i.e. the chroma/luma information ratio per line).
- The third digit represents the vertical subsampling factor of the chroma channels (i.e. chroma/luma information ratio for two subsequent lines). Only consumer products make use of this kind of subsampling. In professional video, this digit is identical with the second.

Appendix

- If a fourth digit is given, it indicates the presence of an alpha channel. An alpha channel contains transparency/opacity information used in postproduction (e.g. keying, compositing) and is provided for each pixel without subsampling.

In a 4:4:4 signal, each pixel has full luminance and chrominance information. As the luma component of an RGB signal is a part of all color channels, an RGB signal is always 4:4:4.

In a 4:2:2 signal, each pixel contains full luminance information, but only every other pixel per line also contains chrominance information. An RGB signal has to be transformed into a color difference signal, such as YCbCr, before it can be subsampled. YCbCr signals can be delivered as a signal using 4:2:2 subsampling, or as a 4:4:4 signal without subsampling.

The ARRIFLEX D-21 can be set to output 4:4:4 RGB or 4:2:2 YCbCr signals.

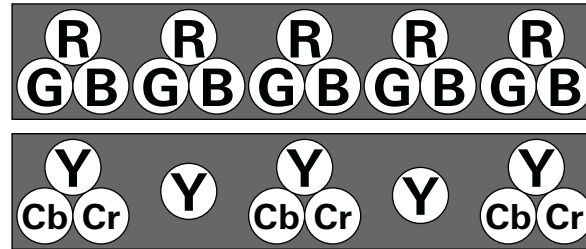

Data Mode

Data Mode delivers a single channel 12bit raw Bayer data image without compression. No image adjustment other than white balance is applied. This raw data could be described as a digital negative, which has to be converted to an RGB image before it can be used.

Bayer pattern - Color Filter Array

An imaging sensor can only differentiate a change in luminance, not color. Hence, the incident light has to be separated into color components. As the D-21 uses a single chip, the color separation is done by means of a color filter array (CFA). A CFA is a small mosaic pattern of color filter dyes. Each pixel is covered with one dye, so it only captures one the luminance information for one color component. One form of a CFA is the *Bayer pattern* with red, green, and blue sensing pixels, which is used for the D-21 sensor.

ARRIRAW Processing

As the RAW Bayer data only contains luminance information, ARRIRAW processing assigns one color component to each pixel, based on the CFA alignment on the sensor. The image now contains three color components, but only one component per pixel. To obtain the remaining two color components for each pixel they have to be interpolated from the surrounding pixels – i.e. color reconstruction. There are different methods for color reconstruction based on processing

speed vs. output quality. Before the RGB image is ready for viewing, the colors need to be transformed to the desired output color space (e.g. for output on HD displays, print on film or digital cinema projection) and the tonal balance has to be adapted using the intended contrast characteristic. The output RGB images are then stored e.g. as 10bit log dpx-files, 16bit tiff-files, or other file formats, depending on postproduction requirements.

ARRIRAW data can be processed in production quality using the ARRI software tool Image Booster or can be output by ARRIRAW T-Link (see below) certified recorders and playback devices as live HD preview or production quality images depending on their specifications.

Note: Please check the Image Booster reference for more information on ARRIRAW processing and output options.

ARRIRAW Output

When set to ARRIRAW, an output board delivers the raw data with:

- 2880 x 2160 pixels in 1.33:1 (4:3) aspect ratio using the full sensor aperture up to 25 fps,
- 2880 x 1620 pixels in 1.78:1 (16:9) aspect ratio using the full sensor aperture width up to 30 fps.

The ARRIRAW output is sent over a dual link HD-SDI connection.

ARRIRAW T-Link

There are different source formats that can be sent over a dual link HD-SDI connection. Next to 4:4:4 RGB, SMPTE 372M also defines 4:4:4:4 RGBA (A for alpha channel, see section Chroma (Sub-)Sampling above) as a source format. The ARRIFLEX D-21 uses a special transport method, which maps the 12 bit raw Bayer data into this 4:4:4:4 RGBA signal so it can be sent to the recording system via a dual link HD-SDI connection. This method is called *ARRIRAW T-Link* (transport link).

ARRIRAW Recording

Any system capable of recording and playing back an SMPTE 372M compliant RGBA signal without compression/encoding can be used to record this signal. ARRIRAW T-Link certified recorders furthermore offer real-time image processing (e.g. Look Up Tables, image resizing and cropping) for live preview on an HD monitor.

Data Mode Benefits

- **Best Image Quality**

Data Mode output offers uncompressed, unprocessed 12 bit ARRIRAW data with the highest dynamic range and lowest noise, allowing to maximize the image quality through advanced image processing in post.

- **Aspect Ratio Range**

Both D-21 and D-21 HD are equipped with a 1.33 (4:3) format sensor. Data Mode on the D-21 allows output of this full sensor image at full sensor resolution, extending the choice of available aspect ratios.

Shooting CinemaScope can be done not only using spherical (flat) lenses, but also anamorphic (scope) lenses, as the sensor can capture the whole image projected by anamorphic lenses. Shooting 2.39:1 with anamorphic lenses uses a larger imager area which delivers twice as many output lines compared to images shot with spherical lenses.

Note: Both D-21 and D-21 HD also offer 1.33:1 (4:3) output using the Mscope process (see below).

- **Flexibility**

D-21 can simultaneously output ARRIRAW for recording and production quality HD for monitoring and editorial. ARRIRAW T-Link certified recorders broaden the options for monitoring and editorial by allowing a larger set of non-destructive image manipulations.

- **Postproduction**

Data Mode output delivers finer detail, crisper edges and higher resolution. Images can be processed to provide the same resolution and colorimetry as 2K film scans for use in familiar 2K workflows. Decisions on output color space and image characteristics can be made in post. Upgraded image processing algorithms can be applied to archived raw data for better image quality.

Dead/Defective Pixels

See Pixel Failure.

HD Mode

HD Mode provides a fully processed 1.78:1 (16:9) live image, ready to be used in HD workflows.

HD422

When set to HD422, an output board delivers standard 1920 x 1080 4:2:2 YCbCr 10 bit HD signals. These signals are sent over a single link HD-SDI connection, can be recorded with any system offering 4:2:2 HD-SDI input (SMPTE 292M) and can be edited using standard HD postproduction equipment.

HD422 dual link/high speed^[1]

When the D-21 is set to HD422 and a frame rate higher than 30 fps, the camera automatically switches to HD422 dual link mode. At e.g. 50 fps, both HD-SDI output boards are used to transmit two synchronized HD video signals at 25 PsF (each containing either even or odd numbered frames) composing the 50 PsF signal. The output frames are marked/flagged (see variable frame rate) so the recording system can correctly merge both signals to the 50 PsF sequence.

Any recorder supporting dual stream/dual camera input basically also supports HD422 dual link signals.

[1] HD422 dual link/high speed not available on D-21 HD.

If the recorder does not provide VariFrame support, even and odd frames may be recorded in the wrong order (frame swapping). This, however, is easily identified as juddering motion in playback and can be resolved in postproduction without a loss of image quality. Recording systems supporting dual link input for 4:4:4 RGB HD signals do not necessarily support HD422 dual link input, as this signal type makes different demands on the recording hardware.

Once recorded, the material can be played back at a lower frame rate, e.g. 25 PsF, allowing the signals to be transmitted using a single link HD-SDI connection. Therefore, the material can also be edited using standard HD postproduction equipment.

HD444

When set to HD444, an output board delivers standard 1920 x 1080 4:4:4 RGB 10 bit HD signals. These signals are sent over a dual link HD-SDI connection and can be recorded with any system offering 4:4:4 dual link HD-SDI input (SMPTE 372M).

The full potential of 4:4:4 RGB images can only be used if postproduction is able to maintain these signals without converting them to 4:2:2 signals until final delivery. Green/blue screen material shot in 4:4:4 should not be converted to 4:2:2 until after chroma-keying. Productions requiring elaborate color timing/correction should maintain 4:4:4 at least until after this step.

Mscope™

Mscope offers the use of anamorphic lenses without the requirement for Data Mode compatible equipment.

Mscope Output

Mscope, like HD Mode, outputs a fully processed image, but uses the full 1.33:1 sensor image to create a 1920 x 1440 oversized HD image. This oversized image is split into two segments, one containing the even lines and the other the odd lines. The segments are output as two synchronized 1920 x 1080 4:2:2 YCbCr 10 bit HD-SDI streams containing a 1920 x 720 letterbox image (2.66:1). When shooting with anamorphic lenses, each stream shows an unsqueezed image that can be used for on set preview and editorial.

Mscope Recording & Postproduction

Any recorder supporting dual stream/dual camera input can record Mscope signals.

Depending on the recording system in use, recombining both streams to the original 1920 x 1440 image may be available as an automated export option or may have to be done after ingest.

As the Mscope image has a de-squeezed aspect ratio of 2.66:1, it provides a some room for repositioning a shot before it is cropped on the sides to the desired output aspect ratio (2.40:1, 2.39:1, 2.35:1). With a

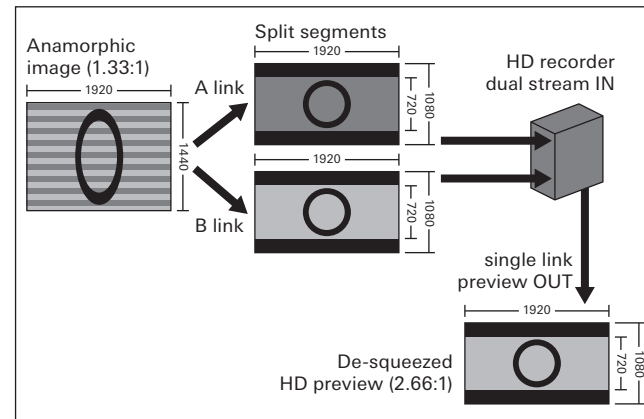

deliverable aspect ratio of 2.40:1, the output would be cropped and, if necessary, de-squeezed to:

- 1728 x 1440 pixels for a 35 mm release print (scope)
- 3546 x 1440 pixels for digital cinema release (flat)
- 1920 x 800 pixels for release on HDTV (flat)

Mscope Benefits

- Fully processed live HD for preview and editorial.
- Mscope image contains approximately 80% more scanning lines than equivalent 2.39:1 images cropped from 16:9 HD images shot with a spherical lens.
- Mscope combines the use of anamorphic lenses with the economy of HD acquisition.

Pixel Failure

There are two types of pixel failures: dead or defective.

Dead pixels deliver no signal at all causing dark spots or spots with a green or cyan color cast in the output image. Dead pixels may occur e.g. after air transportation, in case of an electrical discharge or when a camera is exposed to severe vibration or shocks.

Defective pixels deliver improper luminance values causing bright red, green or blue spots in the output image. If a pixel failure occurs after a camera has arrived on the set, this is more likely a matter of a defective than a dead pixel. A pixel is considered to be defective when it outputs false signal levels. Defective pixels may recover over time, whereas dead pixels have no chance of recovery.

ARRI Imaging Technology (AIT) inside the D-21 & D-21 HD provides an automated Defect Pixel Correction (DPC), which instantly identifies a pixel failure and corrects it with information gathered from the surrounding pixels. If a whole cluster of adjacent pixels fails, the DPC relies on a defective/dead pixel map, which can be updated on location by a trained D-21 service technician, in an ARRI service center or at an ARRI rental facility.

Scanning Methods (p, i, PsF)

Progressive Scan (p)

After each exposure, the full frame is captured/output from the sensor. This scanning method provides the highest resolution per frame and is comparable to the way images are captured on film. It delivers good material for keying or masking in postproduction. The only problem is fast motion or fast panning, which easily results in jittering/juddering images. Shooting with higher frame rates eliminates this effect.

Progressive material is denoted with the letter "p", attached to the image format:

- 720p - progressive HD with 1280 x 720 resolution
- 24p - progressive HD at 24 frames per second
- 1080/24p - progressive HD with 1920x1080 resolution at 24 fps.

Interlaced Scan (i)

After each exposure, odd (1,3,5...) or even (2,4,6...) lines of the full frame are alternately captured/output from the sensor, as so called fields. Two sequentially output fields make up one frame. Fields are output at twice the frequency of frames from progressive capture. This principle bases on the afterglow of CRT phosphors and the characteristics of human vision, which results in two fields being perceived as a continuous image once the frequency is high enough. Due to the higher frequency of the fields, this scanning method provides a smooth motion representation. Fast horizontal movement or quick pans, however, cause jagged vertical edges in the image, as the two fields composing a frame are captured one after another. This reduces the quality of keying or masking in postproduction. Interlaced material usually has to be de-interlaced (combining fields to frames), before it can be worked on using today's post processes.

Interlaced material is denoted with the letter "i", attached to the image format:

- 1080i - interlaced HD with 1920x1080 resolution
- 25i - interlaced material at 25fps i.e. 50 fields/sec
- 1080/25i as a combination of the above.

Some people prefer relating to fields per second rather than frames per second, e.g. 50i or 60i.

As current cameras also offer progressive capture of 50 or 60 fps, the declaration of fields per second can be rather confusing.

Progressive Segmented Frame (PsF)

This is not a scanning method used for capturing, but a transmission method. Basically, a progressively captured frame is segmented into two fields, which are then transmitted similar to an interlaced signal. This enables devices that usually work with interlaced material to also work with progressive material. The notable difference to an interlaced scan signal is that both fields originate from the same frame and have not been captured sequentially. Therefore, transmitting progressive scan material using PsF means no loss in image quality. Motion representation and resolution is exactly the same as in progressive scan material.

Progressive segmented frame material is denoted with the letters "PsF", attached to the image format:

- 1080/25PsF - progressive HD with 1920x1080 resolution at 25 fps, transmitted as PsF.

Signal Range

The luminance levels in a scene are represented as amplitude levels in a recorded video signal. More exposure outputs higher signal levels. Overexposure eventually results in white clipping – image areas with a signal level at the upper limit with no definition left. In analogue video, the signal amplitude is expressed as voltage or IRE units. In digital video, a set of discrete digital code values is used to represent the continuous luminance range.

The signal range defines upper and lower limit of the video signal representing the luminance values of black and pure white:

- Normal range (also called legal or safe range) signals use code values from 64 to 940 (0 – 100%).
- Extended range (also called full range) signals use code values from 4 to 1019 (-10 – 110%).

As both ranges describe the same luminance-range of a scene, an extended range signal does not provide more dynamic range, but a finer gradation of the same dynamic range. This mostly improves the quality of black level reproduction.

Normal range is commonly used for HD signals with 4:2:2 chroma sub-sampling. Extended range 4:2:2 HD signals are rather unusual. 4:4:4 HD signals use either normal or extended range, depending on the postproduction workflow.

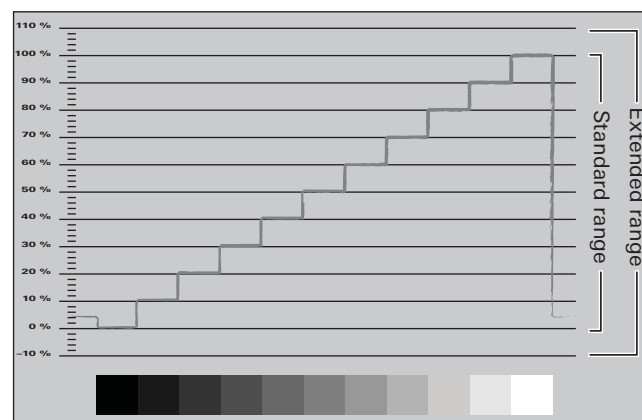

The choice whether to use extended or normal range signals should not be made by the cinematographer alone, as it greatly depends on the options postproduction can offer. Material exposed without clipping in an extended range signal can still be clipped at 100% and/or 0% video level in postproduction, either due to unknowingly wrong settings or due to equipment limitations. This destroys important detail information in highlights and/or dark areas. Of course, the information can be recovered by ingesting the material once more. However, if the problem is based on equipment limitations it may require additional hardware. To save costs, it is therefore important to agree on a signal range in advance.

16. Index

Symbols

4:2:2 YCbCr.....	51, 86, 122, 130, 133
4:4:4 RGB.....	51, 86, 122, 130, 133
11-pin Fischer socket.....	21, 101
12 V accessory socket.....	21
24 V accessory socket	22

A

acceptable temperature range	120, 123, 126
accessories.....	98
external synchronization unit ESU-1	98
fiber link remote FLR-1.....	108
fiber link unit FLU-1.....	107
flash mag mounting adapter FMA-1	99
heated eyecup HE-4/HE-5	100
incompatible accessories.....	96
isolating power adapter IPA-1	21, 101
low mode support.....	102
remote run switch RS-4.....	104
RS socket distributor.....	105
wireless remote control WRC-2.....	110
work light	111
accessory power supply	21
accessory socket.....	21, 22, 88
ACC socket.....	88
acoustic warning.....	83
advanced mode.....	42
air-drying cartridge.....	23, 115, 125

ALL (1>2>SD)	48
anamorphic viewfinder AVF-1	36
aperture	121, 122
ARRIGLOW.....	38
adjusting brightness.....	38
exchanging the format mask	38
ARRIRAW	50, 51, 70, 86, 126, 131
ARRIRAW T-Link	132
AVF-1 anamorphic viewfinder.....	36

B

battery information	80
battery VCLX/2.....	19
bridge plate	25
attaching to camera	26
BP-8, BP-9.....	25
converting to Super 35	25
buffer battery, replacing.....	77
buttons	
MODE.....	72
PHASE.....	20, 75, 79, 113, 124
PROG.....	75
RUN.....	71, 105
SEL	72–85
SET	72–85
video menu	41, 43

C

cable
 KC-20S 18, 19, 23
 KC-29S 18, 19, 23

camera
 camera body 24
 camera care 112
 camera display 20, 40, 72–85, 98, 126
 check imager 112
 cleaning 114, 117
 configuration 40
 installation 23
 main switch 20
 menu 40, 71
 operation 71
 remote control 90, 93, 94
 starting/stopping 71
 troubleshooting 123
 video menu 40

CCU socket 88, 94, 95

channel selection 91

charger for battery VCLX/2 19

code 43

color matrix 53

color temperature 44–46

compatibility 95

condensation 23, 115, 125

connections 119
 composite video connector 40
 CVBS connector 40

HD-SDI connector 40, 66–70, 86, 99, 101, 107

S-Video connector 40, 59

Y/C connector 40

continous current 21, 22

contrast characteristics 54

contrast filter 34

controlled lens motor CLM-2 29, 88, 93, 94, 95

D

data mode 50, 70, 126, 131

dead/defective pixels 133

default settings 63

diagnostics 61, 123

dimensions 120

dioptr adjustment 32

display 72
 battery information 80
 frame counter 80
 lock 75
 Mode 1 73, 75, 81
 Mode 2 73, 77, 98
 Mode 3 73, 81, 82
 Mode 4 73, 83, 84
 Mode 5 73, 85
 monitoring defective 123
 overview of display modes 73
 shutter angle 75
 symbols 74

dust 13, 14, 30, 113, 114, 127

dynamic range distribution 55

E	
El characteristic curves	55
El setup.....	56
extended range	52
external synchronization unit ESU-1	98
eyepiece	32
adjusting the diopter	32
attaching	32
removing	32
F	
FEM-2	88
compatibility	95
radio channel, changing.....	91, 92
radio receiver URM-3.....	90
replace.....	96
status indicators.....	89, 92
fiber link remote FLR-1	108
fiber link unit FLU-1	107
field lens, cleaning.....	117
fine-tuning the programmed frame rate	78
firmware version	17
flash mag mounting adapter FMA-1	99
format marking setup.....	60
frame counter	80, 81
frame rate	46
changing while camera is running.....	78
fine-tuning.....	78
link speed	138
programmed frame rate.....	47, 77
ramping.....	79
setting and storing	46, 76
shifting phase.....	79
standard frame rate.....	41, 47, 76–79, 124, 126, 128, 138
variable frame rate	47, 77, 79, 87, 138
friction	
eyepiece	32
viewfinder arm	33
fuses.....	18, 123
G	
general description.....	16
glossary	129
ARRIRAW	131
ARRIRAW recording	132
ARRIRAW T-Link.....	132
bayer pattern.....	131
chroma (sub-)sampling	129
clipping.....	129
color signals	129
data mode	131
dead/defective pixels	133
HD422	133
HD422 dual link/high speed.....	133
HD444.....	133
HD mode	133
interlaced scan	136
Mscope	134
pixel failure.....	135
progressive scan	135

progressive segmented frame136
 scanning methods.....135
 signal range.....137
 variable frame rate138
 VariFrame138
 grip system..... 28
 low mode support.....28, 35, 102, 103, 107
 removing 28
 ground glasses 37
 exchanging..... 37
 special forceps 37
 ground loop.....21

H

handgrip 28
 HD42237,
 47, 50, 51, 56, 63, 65, 66, 67, 69, 86, 121, 122, 133, 138
 HD444 37, 47, 50, 51, 56, 57, 58, 65, 68, 86, 121, 122, 133
 HD mode42, 50, 133
 HD-SDI
 23, 40, 48, 49, 50, 51, 52, 56, 57, 58, 63, 65, 66, 67, 68,
 69, 70, 79, 86, 99, 101, 107, 116, 119, 121, 122, 126, 128
 HD-SDI mode 50
 HE-4/HE-5 100
 heated eyecup HE-4/HE-5..... 100
 HMI light..... 85
 humidity 12, 23, 115, 125

I

image orientation
 automatic 34
 image orientation 34
 manual 34
 imager check..... 72, 112
 imaging status LED 20
 incompatible accessories..... 96
 index pin 30
 installation 23
 interlaced scan136
 IPA-1 21, 101
 isolating power adapter IPA-1 101

K

KC-20S..... 18

L

LCS bus socket..... 88
 LDD socket 88, 89
 Lens Data System LDS..... 29, 88, 89
 lenses 29
 attaching 30
 lens support LS-9/LS-10 27
 remote control 93
 support..... 27
 lens mount..... 13, 23, 27, 29, 30, 125
 lens support ring 27
 LOCK switch..... 41, 75, 123
 log C setup 57
 log F setup..... 58

low mode support	28, 35, 102, 103, 107
M	
main camera switch	20
mains unit NG 12/26 R	18
maintenance	112
mirror shutter	119
angle measurement	75
displaying shutter angle	75
enable/disable	84
position	20
set angle	85
Mode 1	73, 75, 81
Mode 2	73, 77, 98
Mode 3	73, 81, 82
Mode 4	73, 83, 84
Mode 5	73, 85
MODE button	72
Mscope	50, 51, 69, 86, 134
N	
normal range	50, 52, 63
NORM-PS/CCU switch	75
O	
onboard monitor	21
operational parameters	42
operation control LED	20, 41, 47, 71, 74
optics	29
OSD tools	41, 44, 59, 64, 116
output	40
data mode/ARRIRAW	50, 51, 70, 86, 126, 131

dynamic range distribution	55
HD422	37, 50, 51, 56, 63, 66, 67, 69, 86, 133, 138
HD444	37, 50, 51, 56–58, 68, 86, 133
HD mode	42, 50
interfaces	40, 121, 122
Mscope	36, 47, 50, 51, 65, 69, 86, 132, 134
overview of available output formats	51
signal	121, 122
video menu	40
output board	48
output range	52, 137
output zebra	59
overload display	21, 22
overview of display modes	73
overview of display symbols	74
P	
packing and transport	23
peak load, current	21, 22
PHASE button	20, 75, 79, 113, 124
shifting phase	79
phase shifting	79
pixel failure	115, 135
PL-mount	13, 23, 27, 29, 30, 125
power cable	
KC-20S	18, 19, 23
KC-29S	18, 19, 23
power supply	18, 120
power supply for accessories	21
power supply voltage display	82



power switch.....	20	SEL button.....	72–85
PROG button.....	74, 75	SET button.....	72–85
programmed frame rate.....	47, 76	setup information digits.....	49
programmed frame rate, setting.....	47, 76	shifting phase.....	79
progressive scan.....	135	shoulder pad.....	106
progressive segmented frame.....	136	shoulder set S-5.....	106
PS/CCU.....	75, 76, 78, 79	shutter angle adjustment.....	85
PS-Mode.....	78	shutter angle display.....	75, 81
R		shutter angle for HMI light.....	85
radio channel.....	92	shutter angle measurement.....	75
radio receiver URM-3.....	90	shutter off.....	84
ramping.....	78, 79, 138	signal connections.....	65
recording.....	86, 119, 121	data mode/ARRIRAW setup.....	70
connections.....	65	HD22 high speed setup.....	67
format setup.....	66, 67, 68, 69, 70, 86	HD422 setup.....	66
starting and stopping.....	86	HD444 setup.....	68
variable frame rate.....	87	Mscope setup.....	69
VariFrame.....	87	signal range.....	52, 137
remote control.....	94	signal wiring instructions.....	65
remote run switch RS-4.....	104	sockets.....	119
RGB.....	129	11-pin.....	21
RS-socket.....	22	ACC.....	88
RS-socket distributor.....	105	BAT.....	18
RUN button.....	71, 105	CCU.....	88, 94, 95
S		CLM-2.....	88, 93
S-5 shoulder set.....	106	LCS bus.....	88, 93, 94
safety instructions.....	12	LDD.....	88, 89
SD mode.....	59	RS.....	22, 105
SD video.....	40, 41, 59, 60	software version.....	17
		sound.....	120

special forceps	37, 39, 117
speed range.....	121, 122
spirit level	25
standard frame rate.....	41, 47, 76–79, 124, 126, 128, 138
standard mode	42
standard reset	63
starting/stopping the camera.....	71
starting/stopping the recording	86
status.....	41, 61, 62, 92, 93
Super 35.....	25, 29
support rings.....	27
support rods.....	25
15 mm.....	25, 27, 102
19 mm.....	25, 27, 102
S-Video.....	40
T	
technical data	119–121
temperature range.....	23, 120, 123, 126
tripod.....	12, 25, 26
troubleshooting	123
U	
URM-3 radio receiver	88, 90, 92
user mode	42
V	
variable frame rate/VariFrame	47, 77, 79, 87, 138
VCLX/2 battery.....	19
VCLX/2 battery charger	19
video assist.....	41, 60, 119
video menu.....	40

advanced mode.....	42
code	43
color matrix	48–50, 53
colour temperature	44–46
contrast characteristic	54
default settings	63
diagnostics.....	61
EI characteristics.....	55
EI setup	56
format marking setup	60
HD-SDI mode.....	50
LOCK switch	41, 75, 123
log C setup	57
log F setup	58
OSD tools	41, 44, 59, 64, 116
output board	48
output range	52
output zebra.....	59
overview of available output formats	51
SD mode	59
SD video mode.....	60
setup information digits	49
standard frame rate.....	46
standard mode	42
standard reset	63
status	61
user mode	42, 43, 63
white balance.....	44–46
video menu button.....	41
viewfinder arm	33



extending	33
friction adjustment.....	33
swivelling	33
turning the eyepiece	32
universal.....	36
viewfinder system	31, 119
adjusting.....	34
ARRIGLOW	38
attaching	36
displays in viewfinder	31
image orientation	34
removing	35
voltage range.....	18
W	
warning displays	31
warnings.....	31
warning signal	82
settings	82
switching on and off	83
volume	83
weight.....	121, 122
white balance	44–46
wireless remote control WRC-2	110
wireless system.....	90, 94
work light	111
WRC-2	94
Y	
YCbCr	129

17. ARRI Group Addresses

World Wide Web: <http://www.arri.com>

Australia: ARRI Australia PTY Limited (Sales & Service)
Unit 6C, 5 Talavera Road, Macquarie Park NSW 2113, Sydney, Australia
Phone: +61 (2) 9855 4308, FAX: +61 (2) 9855 4301
Email: ssedlmeier@arri.com.au

Canada: ARRI Canada Limited (Sales & Service)
415 Horner Ave. Unit 11, Toronto, Ontario M8W 4W3, Canada
Phone: +416 255 3335, FAX: +416 255 3399
Email: email@arrican.com

Germany: Arnold & Richter Cine Technik (Headquarters, Sales & Service)
Türkenstraße 89, D-80799 Munich, Germany
Phone: +49 (0)89 3809-0, FAX: +49 (0)89 3809-1244
Email: webmaster@arri.de

ARRI Camera Rental (Film Equipment Rental)
Türkenstraße 89, D-80799 Munich, Germany
Phone: +49 (0)89 3809-1240, FAX: +49 (0)89 3809-1798
Email: mjahn@arri.de

Great Britain: ARRI GB Limited (Sales & Service)
2 Highbridge, Oxford Road, Uxbridge, Middlesex, UB8 1LX, England
Phone: +44 (0)1895 457 000, FAX: +44 (0)1895 457 001
Email: sales@arri-gb.com

ARRI MEDIA (Camera Rental)
3 Highbridge, Oxford Road, Uxbridge, Middlesex, UB8 1LX, England
Phone: +44 (0)1895 457 100, FAX: +44 (0)1895 457 101
Email: info@arrimedia.com

ARRI Lighting Rental (Lighting Rental)
4 Highbridge, Oxford Road, Uxbridge, Middlesex, UB8 1LX, England
Phone: +44 (0)1895 457 200, FAX: +44 (0)1895 457 201
Email: tross@arrilightingrental.com

Italy: ARRI Italia S.r.l. (Sales & Service, Milan)
Viale Edison 318, 20099 Sesto San Giovanni (Milan), Italy
Phone: +39 (0)2 262 271 75, FAX: +39 (0)2 242 1692
Email: info@arri.it

ARRI Italia S.r.l. (Sales & Service, Rome)
Via Placanica 95, 00040 Morena (Rome), Italy
Phone: +39 (0)6 726 707 97, FAX: +39 (0)6 723 1541
E-mail: catalano@arri.it

USA: ARRI Inc. (Sales & Service, East Coast)
617 Route 303, Blauvelt, NY 10913-1123, USA
Phone: +1 914 353 1400, FAX: +1 914 425 1250
Email: arriflex@arri.com

ARRI Inc. (Sales & Service, West Coast)
600 North Victory Blvd., Burbank, CA 91502-1639, USA
Phone: +1 818 841 7070, FAX: +1 818 848 4028
Email: brussell@arri.com

ARRI CSC Camera Service Center (Film Equipment Rental, NY)
619 West 54th St, New York, NY 10019, USA
Phone: +1 212 757 0906, FAX: +1 212 713 0075
Email: ctamarro@arricsc.com

ARRI CSC Camera Service Center (Film Equipment Rental, Florida)
2385 Stirling Road, Fort Lauderdale, FL 33312, USA
Phone: +1 954 322 4545, FAX: +1 954 322 4188
Email: estamm@arricsc.com

Technical data subject to change without notice.

© ARRI 2009

Available languages:
English - Ident-No. K5.70403.0



ARNOLD & RICHTER CINE TECHNIK

Türkenstr. 89
D-80799 München
Phone +49 89 3809-0
Fax +49 89 3809-1244
www.arri.com