

SONY®

DIGITAL MOTION PICTURE CAMERA

F65



OPERATION MANUAL
1st Edition (Revised 3)

English

Before operating the unit, please read this manual thoroughly and retain it for future reference.

WARNING

To reduce the risk of fire or electric shock, do not expose this apparatus to rain or moisture.

To avoid electrical shock, do not open the cabinet. Refer servicing to qualified personnel only.

Caution

Use of controls or adjustments or performance of procedures other than those specified herein may result in hazardous radiation exposure. Do not open the outer case and disassemble or otherwise modify.

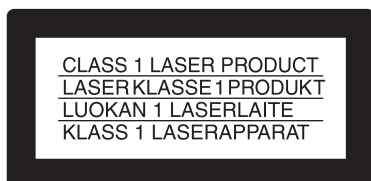

This Digital Motion Picture Camera is classified as a CLASS 1 LASER PRODUCT.

Tämä Digital Motion Picture Camera on luokiteltu 1. LUOKAN LASERTUOTTEEKSI.

Den här Digital Motion Picture Camera klassificeras som en LASERPRODUKT AV KLASSE 1.

VAROITUS!

LAITTEEN KÄYTTÄMINEN MUULLA KUIN TÄSSÄ KÄYTTÖOHJEESSA MAINITULLA TAVALLA SAATTAA ALTISTAA KÄYTTÄJÄN TURVALLISUUSLUOKAN 1 YLITTÄVÄLLE NÄKYMÄTTÖMÄLLE LASERSÄTEILYLLE.

WARNING

OM APPARATEN ANVÄNDS PÅ ANNAT SÄTT ÄN I DENNA BRUKSANVISNING SPECIFICERATS, KAN ANVÄNDAREN UTSÄTTAS FÖR OSYNLIG LASERSTRÅLNING, SOM ÖVERSKRIDER GRÄNSEN FÖR LASERKLASS 1.

Internal Laser Module Properties

Wavelength	: 850 nm
Emission duration	: Pulse Modulation
Laser output power	: 4 mW/channel (max)
Standard	: IEC60825-1 (2007)

Egenskaber for internt lasermodul

Bølgelængde	: 850 nm
Strålingsvarighed	: Pulsmodulering
Afgivet lasereffekt	: 4 mW/kanal (maks.)
Standard	: IEC60825-1 (2007)

Egenskaber för intern lasermodul

Våglängd	: 850 nm
Strålningens varaktighet	: Pulsmodulation
Lasereffekt	: 4 mW/kanal (max)
Standard	: IEC60825-1 (2007)

Egenskaber for innvendig lasermodul

Bølgelengde	: 850 nm
Strålingsvarighet	: Pulsmodulasjon
Utgangseffekt for laser	: 4 mW / kanal (maks.)
Standard	: IEC60825-1 (2007)

Caution

The use of optical instruments with this product will increase eye hazard.

For the customers in the U.S.A.

This equipment has been tested and found to comply with the limits for a Class A digital device, pursuant to Part 15 of the FCC Rules. These limits are designed to provide reasonable protection against harmful interference when the equipment is operated in a commercial environment. This equipment generates, uses, and can radiate radio frequency energy and, if not installed and used in accordance with the instruction manual, may cause harmful interference to radio communications. Operation of this equipment in a residential area is likely to cause harmful interference in which case the user will be required to correct the interference at his own expense.

You are cautioned that any changes or modifications not expressly approved in this manual could void your authority to operate this equipment.

All interface cables used to connect peripherals must be shielded in order to comply with the limits for a digital device pursuant to Subpart B of Part 15 of FCC Rules.

This device complies with Part 15 of the FCC Rules. Operation is subject to the following two conditions: (1) this device may not cause harmful interference, and (2) this device must accept any interference received, including interference that may cause undesired operation.

For the customers in Canada

This Class A digital apparatus complies with Canadian ICES-003.

For the customers in Europe

This product with the CE marking complies with the EMC Directive issued by the Commission of the European Community.

Compliance with this directive implies conformity to the following European standards:

- EN55103-1: Electromagnetic Interference(Emission)
- EN55103-2: Electromagnetic Susceptibility(Immunity)

This product is intended for use in the following Electromagnetic Environments: E1 (residential), E2 (commercial and light industrial), E3 (urban outdoors), E4 (controlled EMC environment, ex. TV studio).

The manufacturer of this product is Sony Corporation, 1-7-1 Konan, Minato-ku, Tokyo, 108-0075 Japan.

The Authorized Representative for EMC and product safety is Sony Deutschland GmbH, Hedelfinger Strasse 61, 70327 Stuttgart, Germany. For any service or guarantee matters please refer to the addresses given in separate service or guarantee documents.

For the State of California, USA only

Perchlorate Material - special handling may apply, See www.dtsc.ca.gov/hazardouswaste/perchlorate
Perchlorate Material : Lithium battery contains perchlorate.

For the customers in Taiwan only



廢電池請回收

AVERTISSEMENT

Afin de réduire les risques d'incendie ou d'électrocution, ne pas exposer cet appareil à la pluie ou à l'humidité.

Afin d'écartier tout risque d'électrocution, garder le coffret fermé. Ne confier l'entretien de l'appareil qu'à un personnel qualifié.

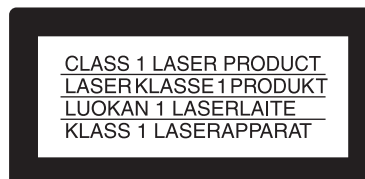

Digital Motion Picture Camera est classée comme PRODUIT LASER DE CLASSE 1.

Propriétés du module laser interne

Longueur d'onde	: 850 nm
Durée d'émission	: Modulation d'impulsion
Puissance du laser	: 4 mW/canal (max)
Norme	: IEC60825-1 (2007)

Pour les clients au Canada

Cet appareil numérique de la classe A est conforme à la norme NMB-003 du Canada.

Pour les clients en Europe

Ce produit portant la marque CE est conforme à la Directive sur la compatibilité électromagnétique (EMC) émise par la Commission de la Communauté européenne.

La conformité à cette directive implique la conformité aux normes européennes suivantes :

- EN55103-1 : Interférences électromagnétiques (émission)
- EN55103-2 : Sensibilité électromagnétique (immunité)

Ce produit est prévu pour être utilisé dans les environnements électromagnétiques suivants : E1 (résidentiel), E2 (commercial et industrie légère), E3 (urbain extérieur) et E4 (environnement EMC contrôlé, ex. studio de télévision).

Le fabricant de ce produit est Sony Corporation, 1-7-1 Konan, Minato-ku, Tokyo, 108-0075 Japon.

Le représentant autorisé pour EMC et la sécurité des produits est Sony Deutschland GmbH, Hedelfinger Strasse 61, 70327 Stuttgart, Allemagne. Pour toute question concernant le service ou la garantie, veuillez consulter les adresses indiquées dans les documents de service ou de garantie séparés.

WARNUNG

Um die Gefahr von Bränden oder elektrischen Schlägen zu verringern, darf dieses Gerät nicht Regen oder Feuchtigkeit ausgesetzt werden.

Um einen elektrischen Schlag zu vermeiden, darf das Gehäuse nicht geöffnet werden. Überlassen Sie Wartungsarbeiten stets nur qualifiziertem Fachpersonal.

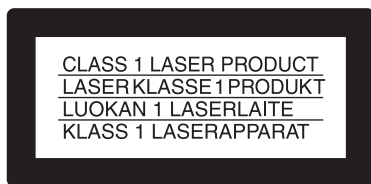

Dieser Digital Motion Picture Camera ist als LASERPRODUKT DER KLASSE 1 eingestuft.

Eigenschaften des internen Lasermoduls

Wellenlänge	: 850 nm
Emissionsdauer	: Pulsmodulation
Laser-Ausgangsleistung	: 4 mW/Kanal (max.)
Standard	: IEC60825-1 (2007)

Für Kunden in Europa

Dieses Produkt besitzt die CE-Kennzeichnung und erfüllt die EMV-Richtlinie der EG-Kommission.

Angewandte Normen:

- EN55103-1: Elektromagnetische Verträglichkeit (Störaussendung)
- EN55103-2: Elektromagnetische Verträglichkeit (Störfestigkeit)

Für die folgenden elektromagnetischen Umgebungen: E1 (Wohnbereich), E2 (kommerzieller und in beschränktem Maße industrieller Bereich), E3 (Stadtbereich im Freien) und E4 (kontrollierter EMV-Bereich, z.B. Fernsehstudio).

Der Hersteller dieses Produkts ist Sony Corporation, 1-7-1 Konan, Minato-ku, Tokyo, 108-0075 Japan.

Der autorisierte Repräsentant für EMV und Produktsicherheit ist Sony Deutschland GmbH, Hedelfinger Strasse 61, 70327 Stuttgart, Deutschland. Bei jeglichen Angelegenheiten in Bezug auf Kundendienst oder Garantie wenden Sie sich bitte an die in den separaten Kundendienst- oder Garantiedokumenten aufgeführten Anschriften.

Table of Contents

Chapter 1 Overview

1-1 Features	7
1-2 Example of System Configuration	9
1-2-1 SR-R4 Docking System	10
1-3 Locations and Functions of Parts	11

Chapter 2 Installation and Preparations

2-1 Mounting the SR-R4	16
2-2 Attaching a Filter	17
2-3 Attaching a Lens	18
2-4 Attaching a Viewfinder	20
2-5 Mounting the Camera on a Tripod	21
2-6 Mounting the CBK-WA01	21
2-7 Preparing the Power Supply	22
2-8 Setting the Date and Time	23

Chapter 3 Basic Adjustments and Settings

3-1 Basic Operation of the Camera	24
3-2 Camera Settings	25
3-3 Basic Settings using the Subdisplay	25
3-3-1 Basic Operation of the Subdisplay	25
3-3-2 Setting the Video Format	26
3-3-3 Setting the Shutter Value	27
3-3-4 Selecting an ND Filter	28
3-3-5 Setting the Sensitivity (EI Value) (Cine Mode)	29
3-3-6 Checking the Highlight Latitude (Cine Mode)	29
3-3-7 Setting the Color Temperature	30
3-3-8 Setting the SDI OUT Output LUT	30
3-3-9 Selecting the Fan Operating Mode	30
3-3-10 Checking the Voltage	31
3-3-11 Checking the Remaining Media	31
3-3-12 Checking the Timecode	31
3-3-13 Assigning Functions to the ASSIGN Buttons	32
3-3-14 Adjusting the Subdisplay Brightness	33
3-3-15 Checking the Self-Diagnostic Results	33

3-4 VF Menu Basic Operation	33
3-5 Setting the Shooting Mode	35
3-6 Setting the Output Signal	36
3-6-1 Selecting the Output Video Signal	36
3-7 Viewing and Setting the Viewfinder Display	37
3-7-1 Viewing the Basic Status Display	37
3-7-2 Setting the Marker Display	37
3-7-3 Setting the Voltage Warning Values	38
3-7-4 Magnifying the Viewfinder Display	38
3-8 Restoring the factory default settings	39

Chapter 4 Menu Configuration and Detailed Settings

4-1 Subdisplay Menu List	40
4-2 VF Menu List	42
4-2-1 Camera Menu	43
4-2-2 VF/SDI Menu	46
4-2-3 Display Info Menu	47
4-2-4 Config Menu	49
4-2-5 File Menu	51
4-2-6 Network Menu	52
4-2-7 Diagnosis Menu	54

Appendix

Metadata	55
RDD 18 format metadata set	55
Non-realtime metadata	57
Warning/Error Messages	58
Precautions	60
Cleaning the Recorder Connector	61
About “Memory Stick Duo”	61
Specifications	63
Connector Pin Assignments	65
Menu Operation using a Web Browser	67
Operation using a Tablet Device	68
Color Space According to the COLOR SPACE	
Settings	70
Notice Concerning Software Governed by the GNU	
GPL/LGPL	71

1-1 Features

The F65 is a digital motion picture camera equipped with a Super 35-mm type CMOS sensor array with a total of 20 Megapixels.

The camera is incorporated with newly developed imagers and a digital signal-processing LSI that yield images of a high quality for cinematic, commercial, and dramatic production applications. The camera also supports the features of a “production camera” up to details in its shape, button and indicator layout, and materials of the parts.

Superior picture quality and high performance

Super 35-mm type CMOS and PL mount

With the F65’s Super 35-mm-type CMOS imagers and PL mount, most movie lenses designed for conventional 35-mm film cameras can be mounted without a converter.

Wide latitude and high-quality pictures

With its newly developed imagers, and unique 16-bit digital LSI, the camera achieves wide latitude and high-grade picture quality with minimal noise.

RAW image output

Outputs RAW image data, without camera signal processing or non-linear gamma processing, for increased convenience during post-production.

Multiple frame formats

The camera supports 3840/4096-pixel wide images for high-end content creation, including commercial and broadcasting program production as well as movie making.

The camera supports the following formats.

F65RAW mode: 23.98p, 24p, 25p, 29.97p, 50p, 59.94p, 59.94p (Select FPS), S60p (Select FPS)

F65RAW-HFR mode: S119.88p (Select FPS), S120p (Select FPS)

HD mode: 23.98p, 24p, 25p, 29.97p, 50p, 59.94p, 59.94p (Select FPS), S60p (Select FPS)

Imaging characteristics with wide color space

Sony’s unique technology color filters allow the camera to capture images with natural-looking color reproduction close to those of the actual scene.

S-LOG gamma and 709(800%) gamma for monitors

The camera is equipped with S-LOG gamma for checking the entire dynamic range of the image, and 709(800%) gamma for general monitoring.

Mechanical rotary shutter

The camera is equipped with a mechanical rotary shutter that eliminates the rolling shutter effect common to conventional CMOS image sensors.

HD shooting

When used with the SR-R4 recorder, the camera can also shoot images in HD mode, in addition to RAW mode. SR-R4 version 1.4 or later is required to record in HD.

HFR (high frame rate) mode

Supports recording at 120 frames per second. Frame rates from 1 to 120 fps can be selected using Select FPS.

In HFR mode, the ND filter is set to Clear, and the mechanical rotary shutter cannot be used.

In addition, only when the frame rate is set to 120 fps, two cameras can be genlocked so that the phase of the images obtained are synchronized.

Design and shape

New compact design

For a high level of mobility in consideration of various shooting situations, such as inside a car, the camera is housed in as compact a body as possible. In addition, buttons and indicators are laid out to provide a familiar and intuitive user interface to users of conventional cinema film cameras.

Dockable system for the SR-R4 Portable Memory Recorder

A dockable interface system for docking with the SR-R4 is employed for versatility under shooting conditions and on-site demands.

Compatible with film-camera accessories

The F65 is designed to be compatible with a variety of film-camera accessories, giving users a broad array of choices. These include ARRIFLEX-made bridge plates, matte boxes, follow focus units, lens focus/zoom/iris servo control units, and more. These film-camera accessories can be attached to the F65 without modification, enabling users who principally work with film to fully utilize their existing assets.

The F65 is equipped with one 12 V DC and connector one 24 V DC¹⁾ output connector to supply power to accessories connected to the camera.

1) To supply accessories with 24 V DC power, the camera must have both 12 V DC and 24 V DC supplies, and the CAM POWER switch must be turned ON.

Assignable buttons

The F65 is equipped with assignable buttons on the side of the camera head.

The operator can assign frequently used functions, such as magnifying the image in the viewfinder, to assignable buttons to call these functions rapidly when working in the field.

Operational versatility

Cine mode

This mode records video without processing, on the presumption color grading is performed in post-production, while applying basic color grading to the VF/SDI outputs.

In Cine mode, the camera can be operated just like a conventional film camera.

Custom mode

This mode allows you to adjust the black/white level and the gain of the main signal when creating images on location.

This mode also supports camera control by connecting a remote control unit (RM).

Shutter control

The shutter speed is adjustable in terms of shutter angle. You can also switch between a mechanical rotary shutter and an electronic shutter.

Monitor output selection

You can select imposition of markers in the monitor output, and also select a look-up table (LUT) for the desired tone of the monitor image. In addition, user-

defined LUTs created using CVP File Editor for F65 can be imported.

Sensitivity adjustment function

In Cine mode, the F65 employs an EI sensitivity indicator for shooting using a light meter, just as for film cameras, to enable overexposure/underexposure processing in post-production.

ASC CDL

American Society of Cinematographers Color Decision List (ASC CDL) is a format for the exchange of basic color grading information, recommended by ASC, that defines functions for slope, offset, power, and saturation. The camera uses these functions to support adjustment of VF/SDI output gain, black level, tone, and saturation. The adjustments made are not reflected in the master video signal, but are saved as metadata in the SR-R4 recorder. When recording, the video can be monitored on the VF/SDI outputs by applying the values in metadata to the recorded material.

Other features

USB host connectors

The camera is equipped with USB connectors (host) for connection with an optional Wi-Fi adapter (CBK-WA01) to enable wireless camera operation from a tablet or other Wi-Fi capable device.

Anamorphic format support

Normal VF/SDI video, without distortion, is output when using a 2x anamorphic lens.

Supports various setup methods

The F65 can be configured from a variety of devices. The basic configuration is performed on the camera's subdisplay. However, detailed settings can be performed from the menu (VF Menu) displayed in the viewfinder or on a monitor connected to the SDI OUT connector. You can also make detailed settings by displaying the menu in a web browser or on a tablet device, such as an iPad.^{1,2)}

1) iPad is a trademark of Apple Inc.

2) The items displayed in the menu that can be configured using a web browser or a tablet device may vary. For details, see "4-2 VF Menu List" (page 42).

1-2 Example of System Configuration

The diagram below shows a system configuration example for use of this camera.

This manual assumes the use of an optional Sony HD Electronic Viewfinder.

For more information about the fittings, connections, or use of additional equipment and accessories, see “Chapter 2 Installation and Preparations” (page 16) as well as the operation manuals for the connected equipment.

Viewfinder

Product	Model name
HD Electronic Viewfinder	HDVF-C30WR, HDVF-C35W, HDVF-20A, HDVF-200

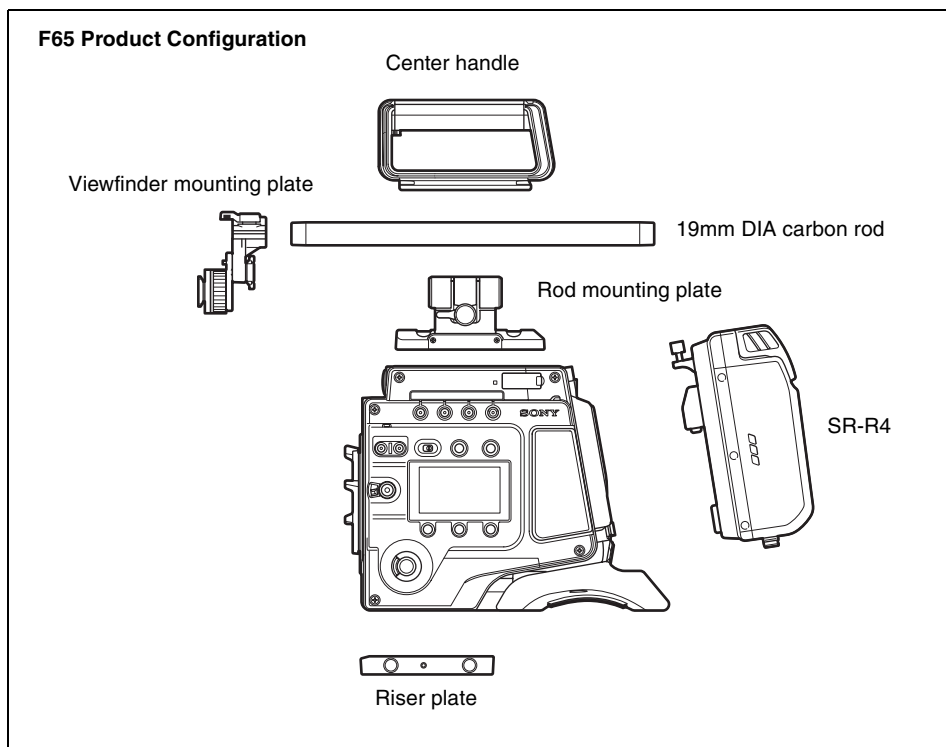

Products for tripod mounting

Product	Model name
Bridge Plate	BP-8 (ARRIFLEX)
Shoulder Set	S-4 (ARRIFLEX)

Video recorder

Product	Model name
Portable Memory Recorder	SR-R4

Note

If attaching and using products, such as a shoulder set, from other manufacturers, check beforehand that the product can be fitted correctly to the camera.

1-2-1 SR-R4 Docking System

An SR-R4 recorder can be docked on the rear of the camera head.
The SR-R4 power source is supplied via the camera's DC IN connector.

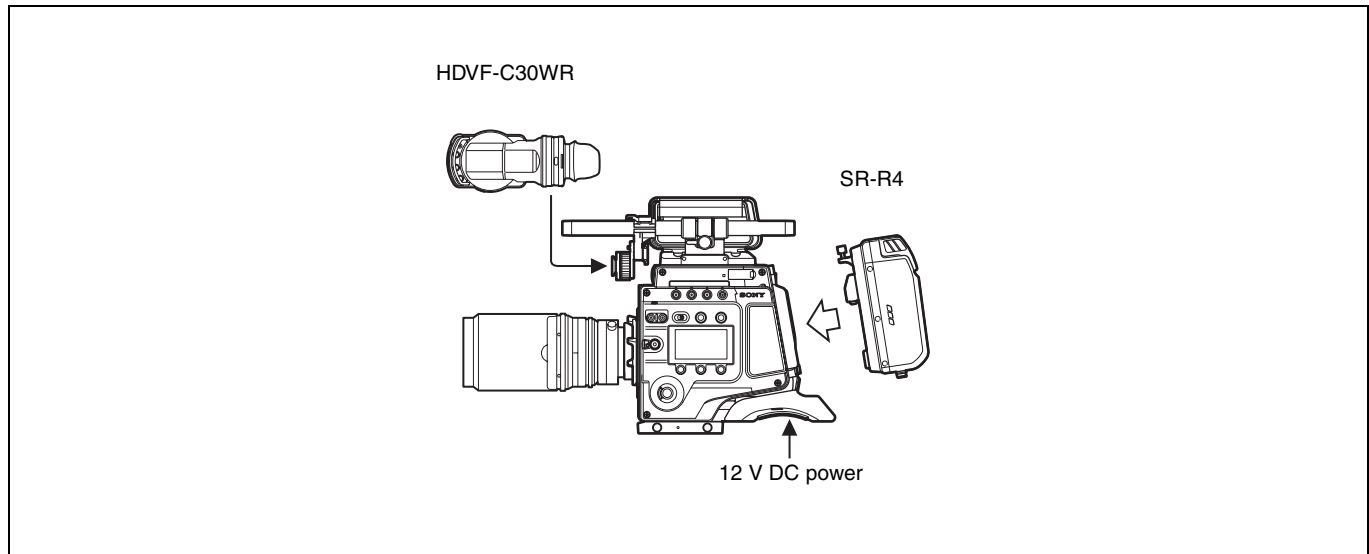

1-3 Locations and Functions of Parts

Front panel

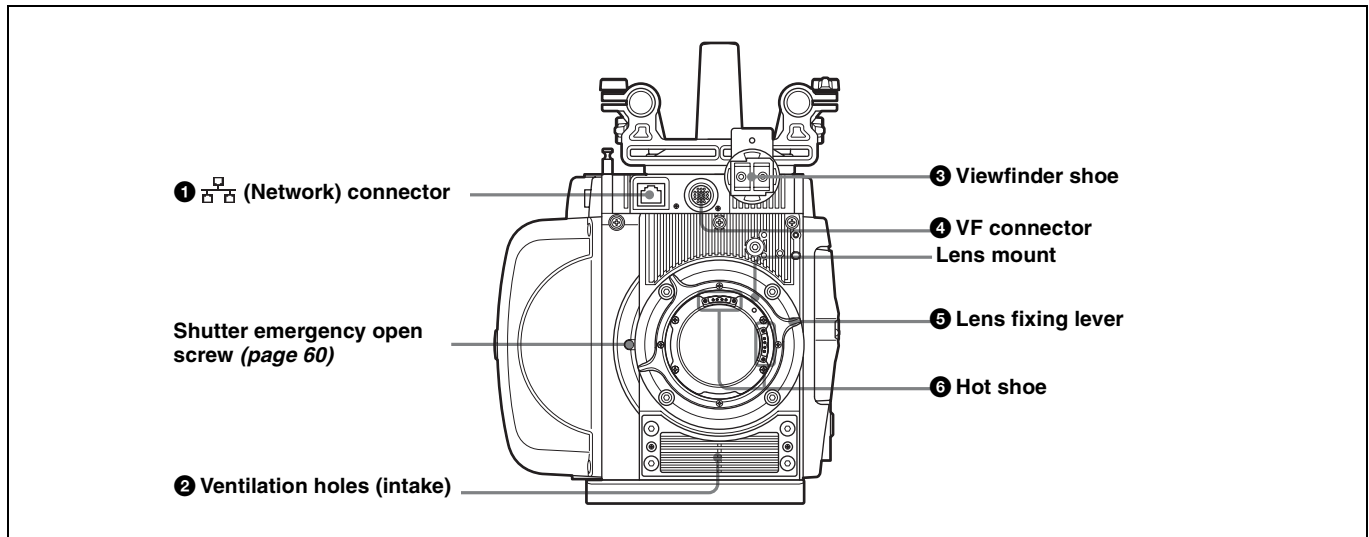

1 (Network) connector (RJ-45 type, 10BASE-T/100BASE-TX)

Connects to a network cable when configuring the camera from a web browser on a computer.

For a network cable connection, the IP address must be configured in the Network menu in the VF menu.

For details, see “4-2-6 Network Menu” (page 52).

CAUTION

- For safety, do not connect the connector for peripheral device wiring that might have excessive voltage to this port. Follow the instructions for this port.
- When you connect the network cable of the unit to peripheral device, use a shielded-type cable to prevent malfunction due to radiation noise.

ATTENTION

- Par mesure de sécurité, ne raccordez pas le connecteur pour le câblage de périphériques pouvant avoir une tension excessive à ce port. Suivez les instructions pour ce port.
- Lors de la connexion du câble réseau de l'appareil au périphérique, utilisez un câble blindé afin d'empêcher tout dysfonctionnement dû au bruit de rayonnement.

VORSICHT

- Aus Sicherheitsgründen nicht mit einem Peripheriegerät-Anschluss verbinden, der zu starke Spannung für diese Buchse haben könnte. Folgen Sie den Anweisungen für diese Buchse.
- Verwenden Sie beim Anschließen des Netzkabels des Geräts an ein Peripheriegerät ein abgeschirmtes

Kabel, um Fehlfunktionen aufgrund von Störungen zu vermeiden.

2 Ventilation holes (intake)

Note

Make sure that a gap of about 8 mm ($1^{11}/_{32}$ inch) is maintained in front of the ventilation holes for cooling.

3 Viewfinder shoe

Attach an optional viewfinder.

For details, see “2-4 Attaching a Viewfinder” (page 20).

4 VF (viewfinder) connector (20-pin)

Connects to the cable supplied with a viewfinder (optional).

5 Lens fixing lever

When mounting a lens, turn the lever clockwise to secure the lens. To remove the lens, turn the lever counterclockwise.

If the lens fixing lever is difficult to operate due to the shape of the lens or accessory being mounted, you can remove the lever and attach it in a different orientation.

For details, see “2-3 Attaching a Lens” (page 18).

6 Hot shoe

Supports the Cooke /i Intelligent Electronic Lens System and can record lens information as metadata.

Left panel

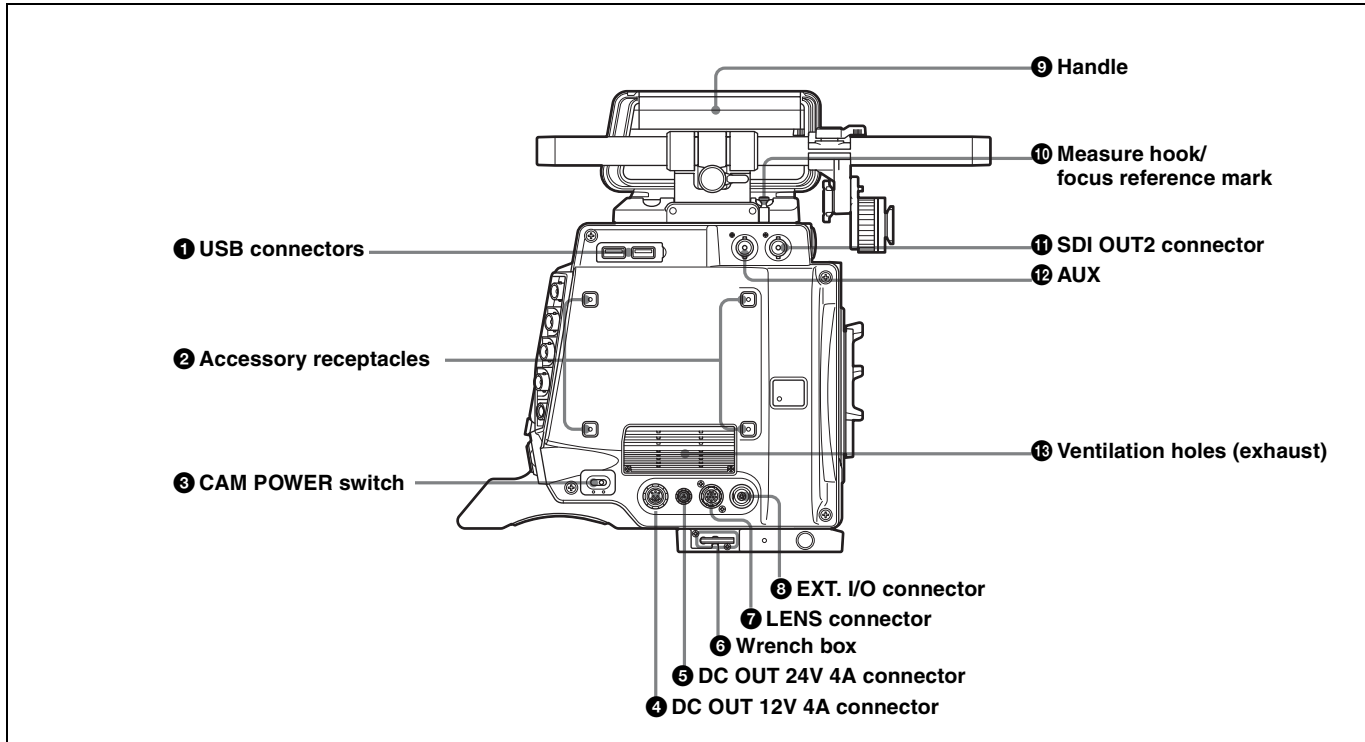

1 USB connectors

USB 2.0 standard connector. Connect a CBK-WA01 Wi-Fi Adapter (optional) to enable communication with wireless LAN devices.

2 Accessory receptacles

For mounting accessories using M3 screws. The depth of the screws is 5 mm ($7/32$ inch).

3 CAM POWER switch

Turns the camera power supply ON/OFF.

4 DC OUT 12V 4A (12 V DC supply output) connector

Supplies 12 V DC power source to accessories, when the CAM POWER switch is in the ON position.

5 DC OUT 24V 4A (24 V DC supply output) connector

Supplies 24 V DC power source to accessories when there is a 24 V DC supply connected to the DC IN connector and the CAM POWER switch is in the ON position.

6 Wrench box

Stores a 3 mm ($1/8$ inch) wrench for attaching/detaching the handle.

7 LENS connector (12-pin)

Controls the aperture remotely with the connection of a commercially-available iris servo unit.

8 EXT. I/O (external control) connector (5-pin)

It is not used in this version.

9 Handle

The handle is attached to the top of the camera head at the factory. It has two sizes of screw holes ($3/8$ " , $1/4$ ") for accessories on the upper side.

10 Measure hook/focus reference mark

Use as reference for focusing.

For actual measurement of the distance from a subject, you can fix the end of a tape measure to the hook.

When shooting shallow depth-of-field images in high resolution, it is recommended that you adjust the focus using the camera or viewfinder magnification function.

11 SDI OUT2 connector (BNC type)

Outputs the same signal as the SDI OUT1 connector on the rear panel.

12 AUX (display only)

This connector is for function expansion. It is not used in this version.

13 Ventilation holes (exhaust)

Note

Connectors and other parts positioned near the exhaust vents may become hot.

Right panel

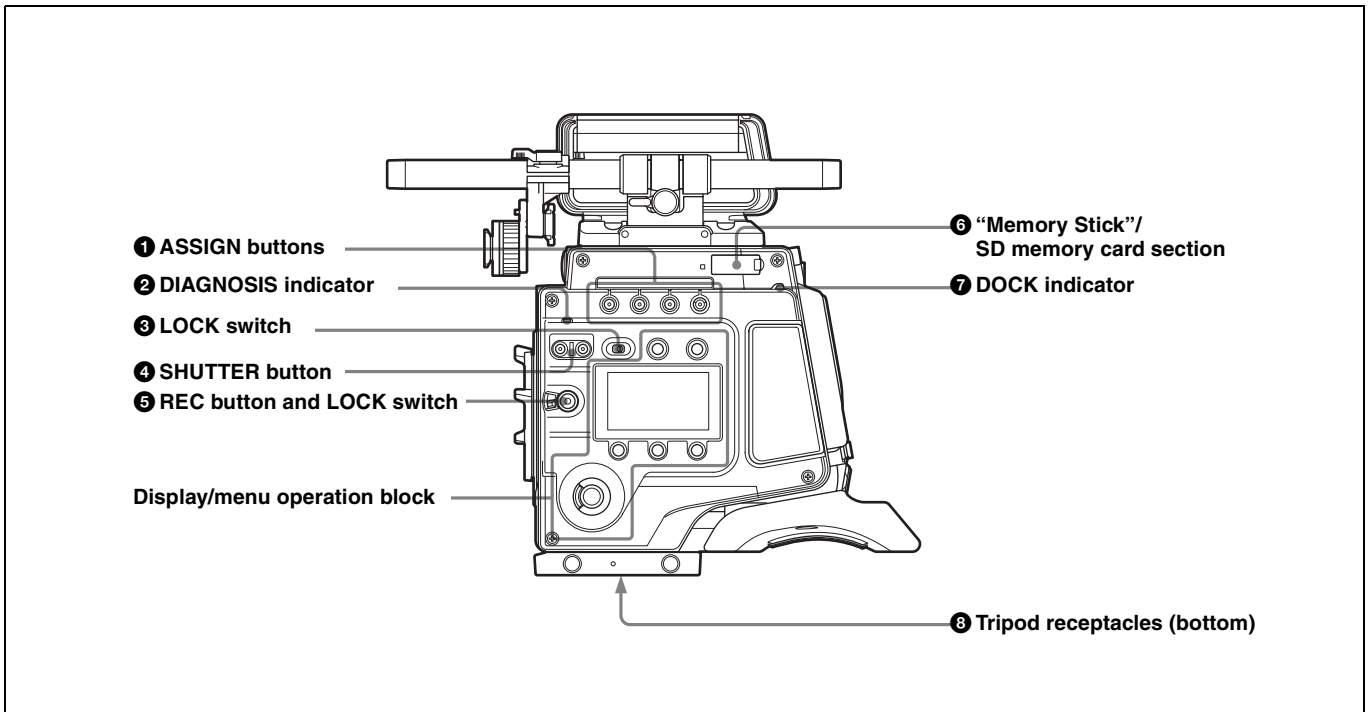

1 ASSIGN (assignable) buttons

You can assign various functions to these buttons, using the subdisplay or the menu displayed in the viewfinder or on a monitor.

ASSIGN button 1 is on the far left, and ASSIGN button 4 is on the far right.

For details, see "3-3-13 Assigning Functions to the ASSIGN Buttons" (page 32).

2 DIAGNOSIS indicator

Indicates the diagnostics status.

Lit green: Normal

Lit red: Error

Flashing red: Fatal error

Lit yellow: Not ready

If the red or flashing red indication continues, consult your local Sony representative.

3 LOCK switch

Locks operation of the side panel (excluding the REC and PAGE buttons).

4 SHUTTER button

Switches between the electronic shutter and the mechanical rotary shutter.

Press the "M." button for one second or longer to switch to the mechanical rotary shutter, or press the "E." button for one second or longer to switch to the electronic shutter.

The button indicator for the selected shutter is lit. The shutter indicator flashes when changing shutter.

Note

It takes about 20 to 40 seconds to change shutter.

5 REC button and LOCK switch

The REC button starts/stops recording to the SR-R4 docked on the camera. The REC button indicator is lit while recording. The indicator flashes as a warning if the connected supply voltage drops.

When the LOCK switch is in the LOCK position, the REC button cannot be operated.

The REC button cannot be operated during REC REVIEW, PLAY, F.FWD, or REW mode on the SR-R4 to prevent overwriting.

For details on warning indications, see "Warning/Error Messages" (page 58).

6 "Memory Stick"/SD memory card section

Slots for a "Memory Stick PRO Duo" and an SD memory card are provided behind the rubber cap. The access lamp turns red when a "Memory Stick PRO Duo" or an SD memory card is inserted into a slot, and then turns off. It flashes red when reading to or writing from a "Memory Stick PRO Duo" or an SD memory card.

When the access lamp is flashing red, do not insert/remove the "Memory Stick PRO Duo" or SD memory card, or turn off the power.

7 DOCK (docking) indicator

When an SR-R4 is docked, the light reception status of the recorder connectors is displayed.

Green: Good

Yellow: Caution level

Sensitivity has decreased, but signal can be transferred without error. Clean the recorder connector or replace the connector optical module as soon as practicable.

Red: Light detection error

A light reception problem occurred, and signal cannot be transferred correctly. Promptly clean the recorder connector or replace the connector optical module.

Off: No signal

For details about cleaning the connectors, see “Cleaning the Recorder Connector” (page 61). For information about replacing the optical module, consult your local Sony representative.

③ Tripod receptacles (bottom)

Mounting point for a tripod using $\frac{3}{8}$ " tripod screws.

Display/menu operation block

Used to switch the monitor display between the subdisplay and the viewfinder, and to operate the menus.

For details on menu operations, see “3-3-1 Basic Operation of the Subdisplay” (page 25) and “3-4 VF Menu Basic Operation” (page 33).

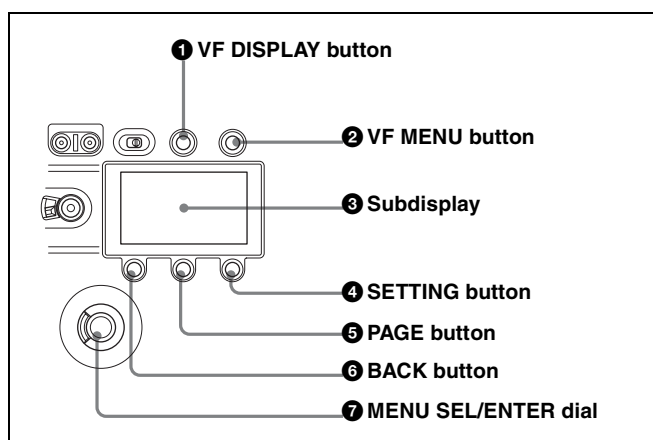
**① VF DISPLAY (viewfinder display) button**

Displays the status screen on the viewfinder and monitor.

For details about the information displayed, see “3-7 Viewing and Setting the Viewfinder Display” (page 37).

② VF MENU (viewfinder menu) button

Displays the menu screen on the viewfinder and monitor.

③ Subdisplay

Displays the camera configuration settings. Press and hold the SETTING button (1 second or longer) to enter Settings Change mode.

④ SETTING button

Press and hold for 1 second or longer to enter Settings Change mode to change camera settings using the subdisplay.

⑤ PAGE button

Displays the next page when the subdisplay is in Settings Change mode.

⑥ BACK button

Cancels changes and returns to the previous screen when the subdisplay is in Settings Change mode or when displaying the menu in the viewfinder or on a monitor.

⑦ MENU SEL (selection)/ENTER dial

Turn the dial to select items and press to enter when the subdisplay is in Settings Change mode or when displaying the menu in the viewfinder or on a monitor.

Rear panel

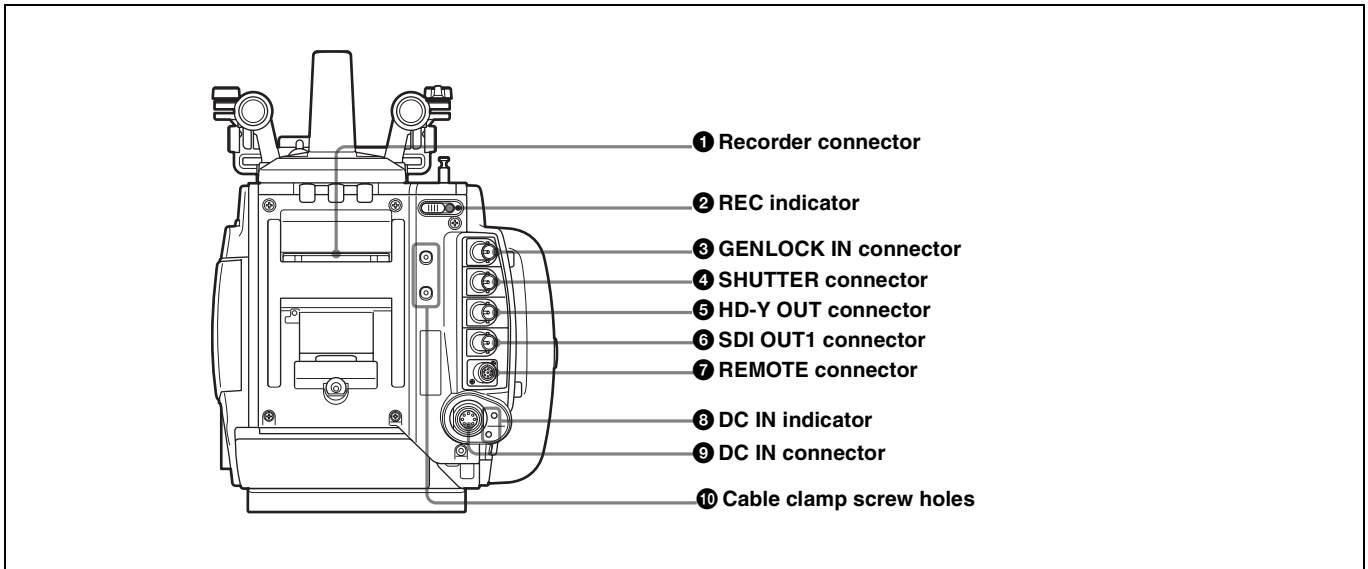

1 Recorder connector

Connects signal and power with the SR-R4 docked on the camera.

Note

Attach the connector cap on the optical connector when not connected to an SR-R4 to protect the connector.

2 REC (record) indicator

The indicator is lit red while the recorder is recording. You can slide the cover to hide the indicator.

3 GENLOCK IN (external sync signal input) connector (BNC type)

Connects to an external sync signal (HD 3-level sync) or HD-SDI signal for camera synchronization. The sync signal is selected in the VF menu.

4 SHUTTER (external shutter) connector

It is not used in this version.

5 HD-Y OUT connector

Outputs the Y-signal for the HD analog component signal. Used to synchronize external analog equipment.

6 SDI OUT1 (SDI output 1) connector (BNC type)

Outputs an HD-SDI signal for connection to a monitor.

7 REMOTE connector (8-pin)

Controls the main line signal with the connection of the optional RM-B170 remote control unit or similar unit (custom mode).

8 DC IN (DC power input) indicator

A 10.5 V to 17 V indicator and 20 V to 30 V indicator are provided. When the CAM POWER switch is turned ON, the corresponding indicator lights up according to the voltage of the power source.

9 DC IN connector (LEMO 8-pin)

Connects to a power cable with the supplied power cable connector.

For details, see “2-7 Preparing the Power Supply” (page 22).

10 Cable clamp screw holes

Can be used to attach the supplied cable clamp.

There are also screw holes on the upper surface on the left panel side.

2-1 Mounting the SR-R4

The SR-R4 docks on the rear of the camera head.

For details about mounting the SR-R4, refer to the Operation Manual of the SR-R4.

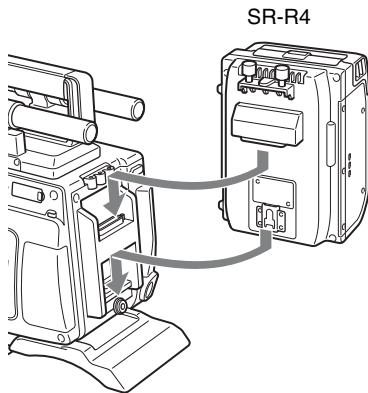

Notes

- Always turn off the camera power supply when mounting the SR-R4.
- The recorder connector for connecting the SR-R4 is an optical connector. Attach the connector cap on the optical connector when not connected to an SR-R4 to protect the connector. After removing the cap, store it in the position shown in the following figure for safekeeping.

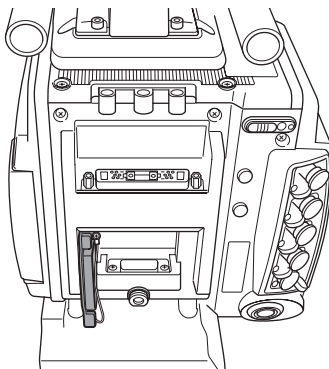

- When mounting the SR-R4, fix the camera head on a tripod in advance to keep the camera head stable.

For tripod mounting, see “2-5 Mounting the Camera on a Tripod” (page 21).

- When the camera is used with the SR-R4 docked, make sure that the camera is securely fixed and stable so that it will not fall over.

2-2 Attaching a Filter

You can mount commercially available gel filters in the supplied filter holder and then attach them to the camera if you wish to use an ND filter in F65RAW-HFR mode or wish to use a filter other than those built into the camera. Recommended filter: Fujifilm neutral density filters

- 1 Place the filter template (metallic disc) on the gel filter, then trim the filter around the edge of the filter template.
- 2 Remove the ring from the filter holder, place the filter on the ring, and then attach the holder.

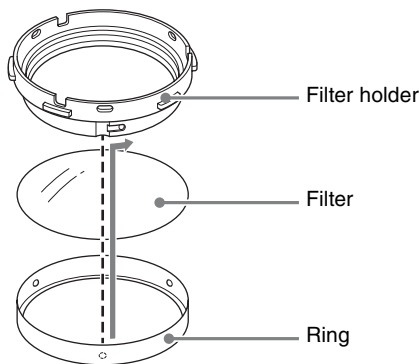

- 3 Align the protrusion on the mounting tool with the notch on the filter holder, then insert the holder into the tool.

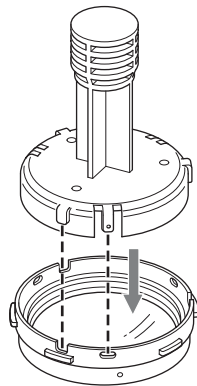

- 4 Align the notch on the filter mount with the protrusion on the filter holder, insert the mounting tool onto the filter mount, and then turn clockwise until it clicks into place.

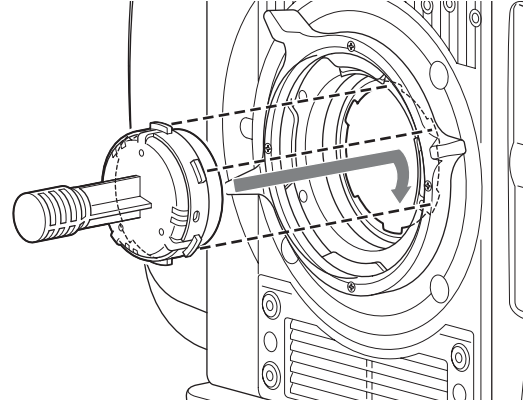

- 5 Pull the mounting tool straight off. The mounting tool separates from the camera, and the filter is mounted in place.

To remove the filter

- 1 Align the protrusion on the mounting tool with the notch on the filter holder, then press the tool onto the filter mount.

Press the tool until it clicks into place.

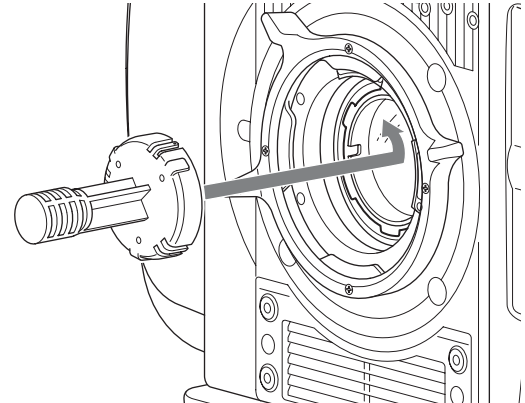

- 2 Rotate the mounting tool counterclockwise, then lift the tool off the camera.

The filter holder is removed with the mounting tool.

2-3 Attaching a Lens

Attach a lens that conforms to the PL lens mount.

Note

Always use a lens whose projection from the flange (A in the figure) is less than 31.5 mm (1 1/4 inch). Use of any lens that protrudes more than 31.5 mm (1 1/4 inch) will damage the internal filter.

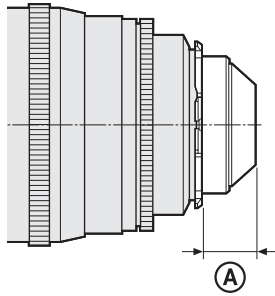

For information on handling lenses, refer to the operation manual for the lens.

- 1 Rotate the lens fixing lever counterclockwise and remove the lens mount cap from the lens mount.

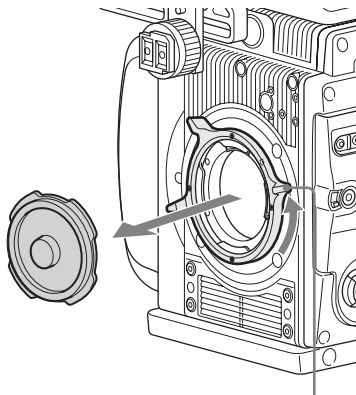

Lens fixing lever

- 2 Align the lens' alignment pin with the notch in the upper part of the lens mount and insert the lens into the mount.
- 3 While supporting the lens, rotate the lens fixing lever clockwise to secure the lens.

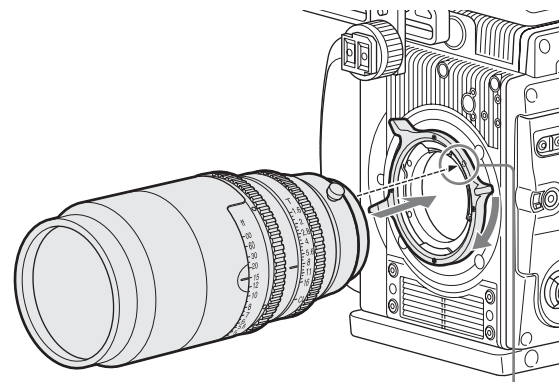

Lens alignment pin

Changing the position of the lens fixing lever

Remove the four screws from the face of the lens fixing lever indicated in the figure. Change the position of the fixing lever, reinsert the screws and securely tighten.

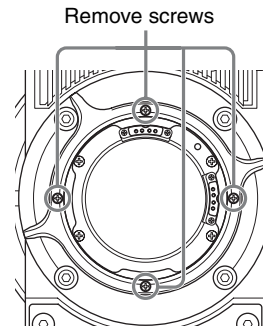

Adjusting the flange focal length

The optical section uses materials not susceptible to thermal expansion, so flange back adjustment is generally not required. However, if you want to make an adjustment, remove the lens mount and replace the shim with one of the appropriate thickness. At shipment, a 0.05 mm (0.0020 inch) shim is installed. The following replacement shims are available.

Note

When using the camera in HFR mode, the lens distance indicator may be slightly off, but this is not a malfunction.

For information about replacing shims, consult your local Sony representative.

Part number	Thickness
4-260-711-03	0.02 mm (0.0008 inch)
4-260-711-13	0.03 mm (0.0012 inch)
4-260-711-23	0.04 mm (0.0016 inch)
4-260-711-33 (standard)	0.05 mm (0.0020 inch)
4-260-711-43	0.06 mm (0.0024 inch)
4-260-711-53	0.07 mm (0.0028 inch)

Part number	Thickness
4-260-711-63	0.08 mm (0.0032 inch)
4-260-711-73	0.09 mm (0.0036 inch)
4-260-711-83	0.10 mm (0.0040 inch)

To change a shim

Note

Exercise care not to damage the internal wiring of the camera when changing the shim. Modifying a shim, scratching a surface, or introducing dust can change the flange back distance and damage the camera such that it cannot be restored to original condition, just as for a film camera.

- 1 Remove the lens mount screws (6).

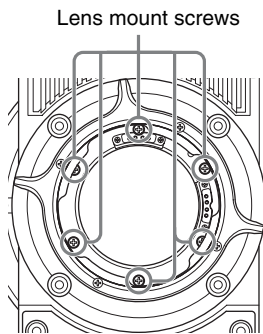

- 2 Pull the lens mount out by about 10 mm ($^{13}/_{32}$ inch) and remove the shim carefully. Pass the shim slit over the wiring, taking care not to pull the wiring, when removing the shim.

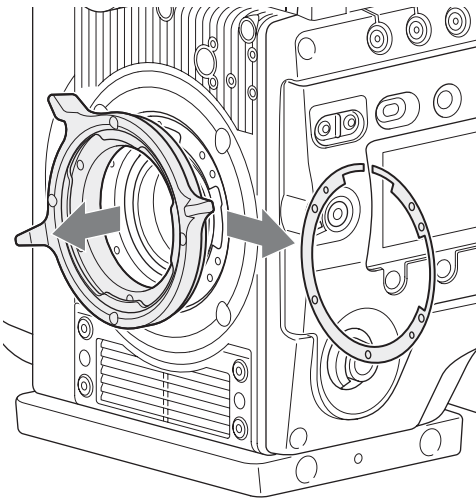

Note

Pulling the lens mount out by more than 20 mm ($^{3}/_{4}$ inch) risks damage to the internal wiring.

- 3 Insert the replacement shim using the shim slit to clear the wiring, and align the camera screw holes and shim alignment pins.

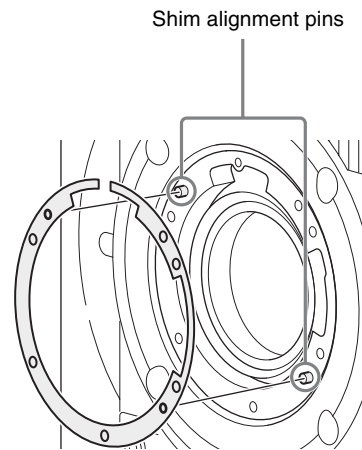

- 4 Reattach the lens mount in its original position, and fasten the screws to a torque of 0.53 N·m (0.39 lbf).

2-4 Attaching a Viewfinder

Caution

When the viewfinder is attached, do not leave the camera with the eyepiece facing the sun. Direct sunlight can enter through the eyepiece, be focused in the viewfinder and cause fire.

For details on the viewfinder, refer to the instruction manual of the viewfinder.

- 1 Pass the viewfinder mounting plate over the two rods.

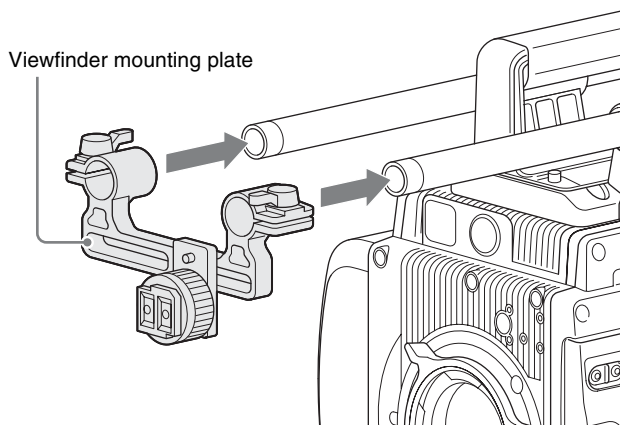

- 2 Slide the slide panel left/right into position, and then turn the lever on the rear of the slide panel to lock it into position.

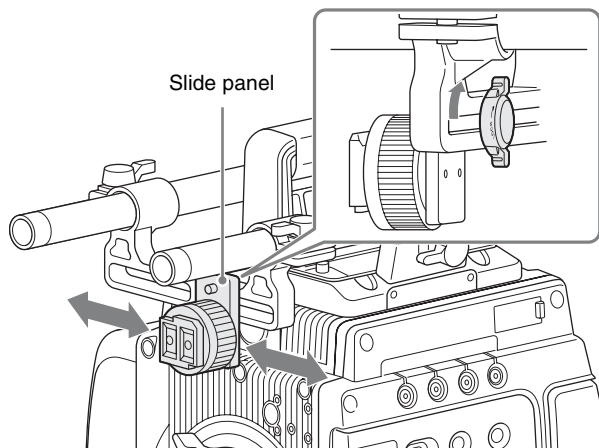

- 3 Slide the viewfinder mounting plate forward/backward into position, and then turn the lever to lock it into position.

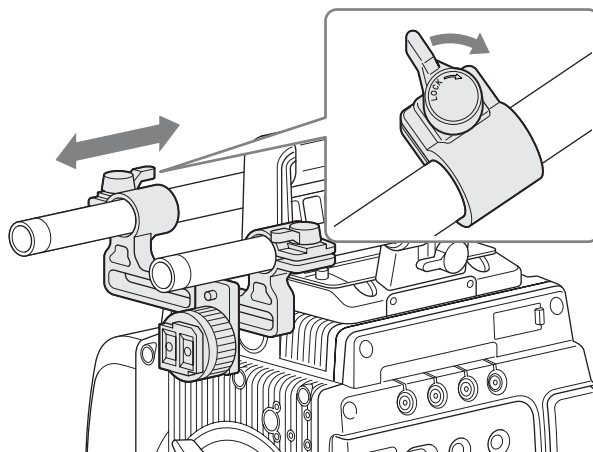

- 4 Fit the viewfinder to the viewfinder shoe and slide the viewfinder horizontally.

The viewfinder stopper automatically pops down.

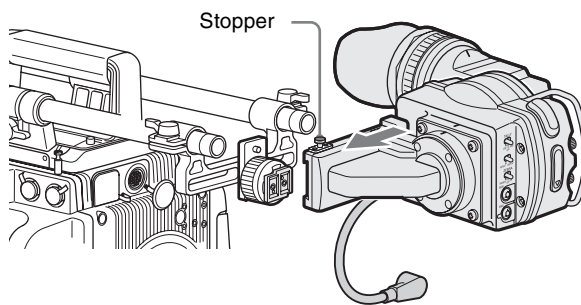

- 5 Set the viewfinder to the most convenient position, tighten the viewfinder positioning ring (① in the figure below), and connect the viewfinder cable to the VF connector of the camera (② in the figure below).

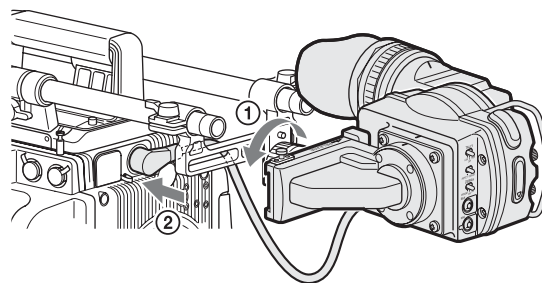

To detach the viewfinder

Loosen the viewfinder positioning ring, pull up the viewfinder stopper, then pull out the viewfinder by sliding it in the direction opposite than when attaching.

2-5 Mounting the Camera on a Tripod

The camera mounts on a tripod using two $\frac{3}{8}$ " tripod receptacles that fit into the base of the camera head.

For details about mounting on a tripod, refer to the operation manual of the tripod.

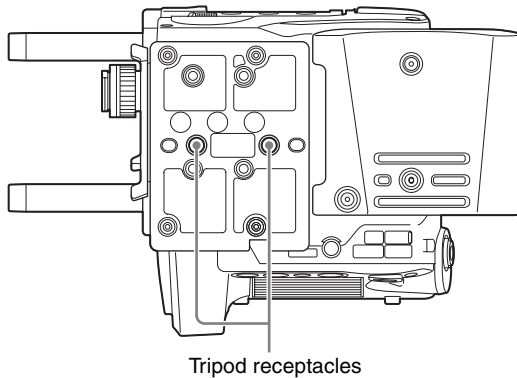

Notes

- Select an appropriate hole, considering the balance of the weight of the camera. If an inappropriate hole is selected, the camera may fall over.
- Check that the size of the selected hole matches that of the screw of the tripod. If they do not match, the camera cannot be attached to the tripod securely.

2-6 Mounting the CBK-WA01

A CBK-WA01 Wi-Fi Adapter can be mounted on the camera using an optional Wi-Fi mounting bracket (part number: 4-418-596-01) for connecting Wi-Fi capable devices to the camera.

For information about obtaining the Wi-Fi mounting bracket, consult your local Sony representative.

- 1 Attach the Wi-Fi mounting bracket onto the camera using the supplied +B3 × 5 screws.

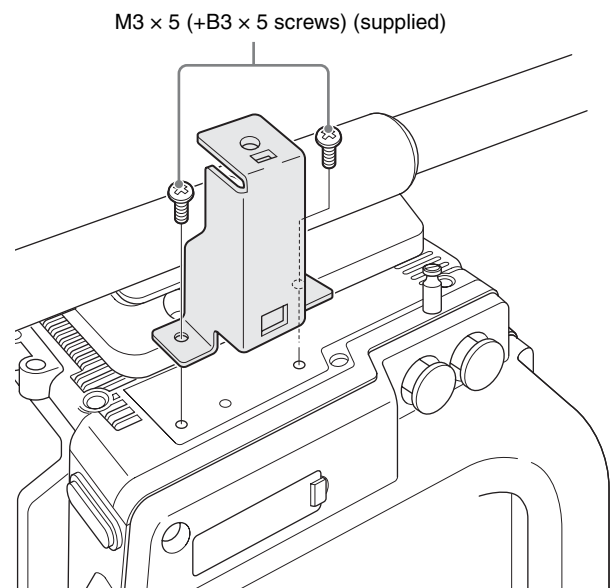

- 2 Place the protrusions on the rear of the CBK-WA01 into the holes in the mounting bracket, and fasten the screw to secure the CBK-WA01 to the bracket.

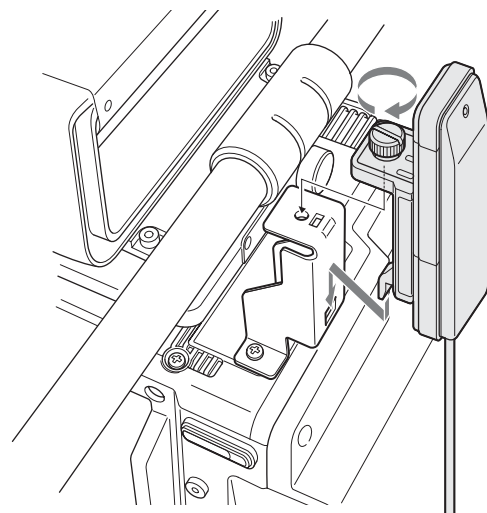

- 3** Connect the CBK-WA01 cable to a USB connector on the camera. Wrap excess cable length around the cable holder.

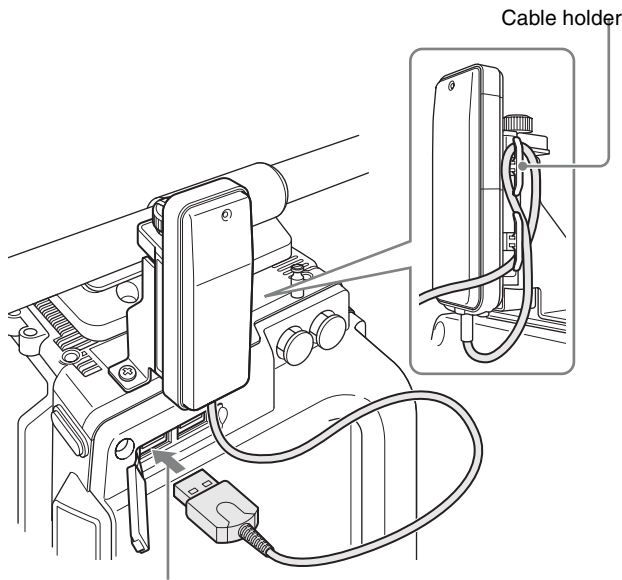

2-7 Preparing the Power Supply

This camera operates at 12 V DC (10.5 V to 17 V). To supply power to the camera, attach the supplied 8-pin power cable connector to a commercially available shielded cable, and then connect the cable to the DC IN connector (LEMO 8-pin) on the camera.

For details on connector pin assignments, see “Connector Pin Assignments” (page 65) in the Appendix. For details on the pin connections, consult your local Sony representative.

Notes

- Use of a power supply with 150 W or higher supply capacity is recommended to safely drive the camera. The specifications for the power supply cable should be chosen such that the voltage drop is less than 2 V. Example: If a 5-meter (16 ft 5 in.) AWG 18 × 3 cable is used to supply the camera and SR-R4, the voltage drop will be 0.5 to 1.0 V.
- If using the camera's 24 V DC output to drive peripherals, 12 V DC and 24 V DC power supplies must be connected to the camera via the DC IN connector (LEMO 8-pin) of the power cable (supplied).
- When using the SR-R4 docked on the camera, the connection of a 13 V to 17 V DC power source is recommended.

To turn on the camera

Set the CAM POWER switch to the ON position, and the camera is turned on.

Power is also supplied to viewfinder connected to the VF connector.

12 V or 24 V power can be fed to accessories via the DC OUT connectors. To supply 24 V power to accessories, 12 V and 24 V DC input power supplies must be connected via the DC IN connector of the camera.

For the pin assignment for the 24 V power supply DC IN connector, see “Connector Pin Assignments” (page 65) in the Appendix.

2-8 Setting the Date and Time

When the camera is used for the first time, the menu for setting the date and time is displayed in the viewfinder. Set the current date and time on the <Date/Hour Meter> page in the Config menu.

To set the menu using a monitor screen, connect a monitor to an SDI OUT connector.

- 1 Turn on the camera power supply.
- 2 Press the VF MENU button.

The menu appears in the viewfinder.

Camera	Camera
VF / SDI	System Format
Display Info	Base Setting
Config	Shutter/FPS
File	Shutter Assign
Network	Video Setting
Diagnosis	Bars/Test Signal

- 3 Turn the MENU SEL/ENTER dial to select Config, then press the MENU SEL/ENTER dial.
- 4 Turn the MENU SEL/ENTER dial to select Date/Hour Meter, then press the MENU SEL/ENTER dial.

The <Date/Hour Meter> page appears.

Date/Hour Meter	
2022 / 2 / 3	3 : 27
Date Type	Y/Mn/D
Hour Meter	3h

- 5 Turn the MENU SEL/ENTER dial to select Date, then press the MENU SEL/ENTER dial.

The date becomes editable.

Date/Hour Meter	
2022 / 2 / 3	3 : 27
Date Type	Y/Mn/D
Hour Meter	3h

- 6 Turn the MENU SEL/ENTER dial to set the date (year, month, day).

Turning the MENU SEL/ENTER dial moves to the next digit. Select the day, then press the MENU SEL/ENTER dial to confirm the setting.

- 7 Turn the MENU SEL/ENTER dial to select Time, then press the MENU SEL/ENTER dial.

The time becomes editable.

- 8 Turn the MENU SEL/ENTER dial to set the time, then press the MENU SEL/ENTER dial.

- 9 Turn the MENU SEL/ENTER dial to select Date Type, then press the MENU SEL/ENTER dial.

- 10 Turn the MENU SEL/ENTER dial to select the date format, then press the MENU SEL/ENTER dial.

You can select one of the following display formats.

Setting	Example display (18th December, 2011)
Y/Mn/D	2011/12/18
Mn/D	12/18

- 11 When finished, press the VF MENU button to exit menu operation.

3-1 Basic Operation of the Camera

The camera operates in two modes: Cine mode and Custom mode. In Cine mode, the camera acquires main line video information, without processing, for color grading in post-production while applying basic grading to the VF and SDI outputs. In Custom mode, images are created on location by adjusting the black/white level and gain of the main line signal.

Cine mode

- Shoots images with a fixed camera gain, and sensitivity specified using a light meter (EI mode).
- Sensitivity can be selected from 200EI, 250EI, 320EI, 400EI, 500EI, 640EI, 800EI, 1000EI, 1250EI, 1600EI, 2000EI, 2500EI, and 3200EI.
- In post-production, the gain can be set to the sensitivity selected during shooting.
- In intensified sensitivity shooting (e.g. 1600EI), the gain is automatically adjusted in response to the selected sensitivity for the VF/SDI/HD-Y outputs, even though the master video output darkens, to maintain appropriate monitoring levels.
- The Master Gain, Black R/G/B/M, White R/G/B, and Gamma R/G/B/M adjustment functions for master video output are fixed at factory default values.
- In HD mode, the video gamma can be set to S-Log2 or selected from user gammas.
- Video adjustment using ASC CDL is supported for the VF/SDI/HD-Y outputs. The adjustments are recorded as metadata together with the video for each frame. The video adjustments made during shooting can be recreated in post production by applying the metadata values to the video.
- The full latitude does not change when the sensitivity setting is changed, but the dynamic range and noise floor changes in post-production with suitable processing. When the sensitivity is set high, the dynamic range increases on one hand, while the noise in dark areas also increases. Conversely, when the sensitivity is set low, the

dynamic range decreases but the noise in the dark areas also decreases.

Custom mode

This mode allows camera gain to be adjusted and black/white level to be adjusted from the camera menu or optional remote control unit (RM) while shooting.

- Camera gain is adjustable in the range -6 dB to $+12$ dB in 3 dB increments (EI adjustment not supported).
- Black/white level is adjustable.
- Black/White, Gain, and following operations can be controlled from a remote control unit.
 - Shutter Speed
 - Filter Select
 - Rec Start/Stop
 - Rec Review
 - Bars/Test Signal
 - 12p Iris Control

The white balance can be set to 3200K (tungsten), 4300K (tungsten), or 5500K (daylight).

The camera supports HD mode recording, where images are down-converted to HD internally and recorded on the SR-R4. The recording format can be selected between HD mode and F65RAW mode.

3-2 Camera Settings

The camera can be configured from the following devices.

Subdisplay

You perform the basic setup configuration using the subdisplay on the side of the camera head.

The basic settings (settings page) is displayed on the subdisplay when power is applied to the camera. Press and hold the SETTING button for 1 second or longer to switch to Settings Change mode. The MENU SEL/ENTER dial, SETTING button and BACK button are used for Settings Change mode operation.

For details about settings on the subdisplay, see “3-3 Basic Settings using the Subdisplay” (page 25). For details about the subdisplay menu list, see “4-1 Subdisplay Menu List” (page 40).

Viewfinder or monitor

Detailed settings can be performed by displaying the menu (VF menu) in the viewfinder or on a monitor connected to an SDI OUT connector.

Press the VF MENU button on the side of the camera to display the VF menu in the viewfinder or on a monitor. The VF MENU button, MENU SEL/ENTER dial, and BACK button are used for VF menu operation.

For details about VF menu operations, see “3-4 VF Menu Basic Operation” (page 33). For details about the VF menu list, see “4-2 VF Menu List” (page 42).

Web browser

If the camera is connected to a network, the menus can be displayed in a web browser on a computer. The settings displayed are almost identical to the display in the viewfinder or on a monitor.

For details about web browser operations, see “Menu Operation using a Web Browser” (page 67).

Tablet device

If the camera is used with the optional Wi-Fi adapter (CBK-WA01), the menus can be displayed on a tablet device, such as an iPad, via a wireless LAN. The settings displayed are almost identical to the display in the viewfinder or on a monitor.

For details about tablet device operations, see “Operation using a Tablet Device” (page 68).

3-3 Basic Settings using the Subdisplay

Basic settings of the camera can be easily performed using the subdisplay. The items set on the subdisplay can also be set using the VF menu.

3-3-1 Basic Operation of the Subdisplay

The buttons and dial shown below are used for operation of the subdisplay.

Side panel of the camera head

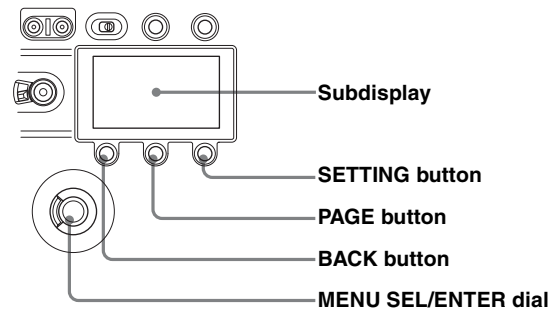

To display the settings pages

After the camera is turned on, the startup screen is displayed on the subdisplay for several seconds, after which the settings page is displayed.

23.98P	
△180.0	ND Clear
800E.I	6.0E
5500K	709 (800%)

Pressing the PAGE button advances to the next page. The following items can be set or checked on each settings page.

Settings page 1

23.98P		1
△180.0	ND Clear	3
800E.I	6.0E	5
5500K	709 (800%)	7
2		4

- 1 Video format
- 2 Shutter value
- 3 ND filter
- 4 Sensitivity (EI value)
- 5 Highlight latitude
- 6 Color temperature
- 7 Look-up table (LUT)

Settings page 2

1	Reel No. 999	Fan Mode MAX	2
3	24.0V 10.8V	Remain 30min	4
	TCG 00:00:00:00		5

- 1 Reel number
- 2 Fan operating mode
- 3 Voltages
- 4 Media remaining
- 5 Timecode

Settings page 3

1	AS1 Mag	AS2 Mag Position	2
3	AS3 OFF	AS4 OFF	4
5	Brightness 4	Diagnosis OK	6

- 1 ASSIGN button 1
- 2 ASSIGN button 2
- 3 ASSIGN button 3
- 4 ASSIGN button 4
- 5 Subdisplay brightness
- 6 Self diagnostics

To change a setting

Press and hold the SETTING button for 1 second or longer. The screen changes to Settings Change mode, and the selected item is displayed in inverse text.

23.98P	
Δ180.0	NDClear
800EI	6.0E
5500k	709(800%)

In this mode, the item you want to set is selected by turning the MENU SEL/ENTER dial. When the item you want to set is shown in inverse text, press the MENU SEL/ENTER dial.

Where there are multiple configuration items, the select screen is displayed.

Select screen (e.g. shutter value)

Shutter	
Step	Δ180.0
Continuous	

On this screen, turn the MENU SEL/ENTER dial to select an item. Press the MENU SEL/ENTER dial to display the change screen for the item.

Change screen (e.g. shutter value)

Shutter	Δ180.0
Δ360.0	
Δ270.0	
✓ Δ180.0	
Δ172.8	

The current value of the setting is displayed at the top right of the screen. Turn the MENU SEL/ENTER dial to select the value, then press the MENU SEL/ENTER dial. The value for the selected item is entered.

To cancel a changed setting

Press the BACK button before confirming the changed setting.

The setting is restored to the original value, and the display returns to the previous page.

Note

Pressing the VF MENU button enables menu operation in the viewfinder or on a monitor, and disables operation using the subdisplay.

Subdisplay when VF MENU button is pressed

23.98P	
Δ180.0	NDClear
800EI	6.0E
5500k	709(800%)

3-3-2 Setting the Video Format

The camera supports the following video format settings.

F65RAW mode:

23.98p, 24p, 29.97p, 25p, 50p, 59.94p, S59.94p (23.98p), S59.94p (29.97p), S60p (24p), S60p (25p)

HD mode (4:4:4 RGB):

23.98p, 29.97p, 24p, 25p, S59.94p (23.98p), S59.94p (29.97p), S60p (24p), S60p (25p)

HD mode (4:2:2 YCbCr):

23.98p, 29.97p, 24p, 25p, 50p, 59.94p, S59.94p (23.98p), S59.94p (29.97p), S60p (24p), S60p (25p)

F65RAW-HFR mode:

23.98pForPB, 29.97pForPB, 24pForPB, 25pForPB,
S119.88p (23.98p), S119.88p (29.97p), S120p (24p),
S120p (25p)

The mode can be switched between F65RAW mode, HD mode, and F65RAW-HFR mode on the <System Format> page in the VF menu.

For details, see “3-5 Setting the Shooting Mode” (page 35).

Note

It is recommended that the power be turned off and back on again after changing the video format.

Changing the video format

- 1 Select the video format on settings page 1, then press the MENU SEL/ENTER dial.

Settings page 1

Video format	
23.98P	
△180.0	NDClear
800EI	6.0E
5500K	709 (800%)

- 2 Turn the MENU SEL/ENTER dial to select the video format, and press the MENU SEL/ENTER dial.

Frame Rate	23.98P
✓23.98P	
29.97P	
59.94P	
S59.94P (23.98P)	

To set using the VF menu

Set on the <System Format> page in the Camera menu (page 43).

VF and SDI OUT connectors output format

Setting the camera main video format automatically determines the signal format that is output on the VF and SDI OUT connectors.

Camera image	VF connector output	SDI OUT connector output
23.98p	23.98PsF	23.98PsF
29.97p	29.97PsF	29.97PsF
24p	24PsF	24PsF
25p	25PsF	25PsF
50p	50i*	50i*

Camera image	VF connector output	SDI OUT connector output
59.94p	59.94i*	59.94i*
S59.94p	59.94i*	59.94i*
S60p	60i*	60i*

* The output image scan type can be set to Interlace or Frame Drop.

3-3-3 Setting the Shutter Value

The shutter of the camera can be viewed and adjusted, with settings displayed as shutter angles, just as for a film camera. Two operation methods are available for the adjustment: stepwise and continuous.

Step mode

Frequently-used shutter angle values can be selected, enabling step selection of the shutter values.

Step No.	Shutter angle
1	360.0 ^{a)}
2	270.0 ^{a)}
3	180.0
4	172.8
5	150.0
6	144.0
7	90.0
8	45.0
9	22.5
10	11.2

a) Selectable for the electronic shutter only.

The corresponding shutter speeds vary according to the frame frequency and frame rate of the selected video format.

Continuous mode (ECS)

The shutter value can be changed smoothly in continuous mode in the range 4.2° to 360.0° (electronic shutter) or 11.2° to 180.0° (mechanical rotary shutter).

To obtain your desired shutter value quickly, select a value nearest your desired one in Step mode, then switch to Continuous mode and adjust the shutter value.

Changing the shutter value in Step mode

In Step mode, one of the registered shutter values can be selected.

- 1 Select the shutter value on settings page 1, then press the MENU SEL/ENTER dial.

Settings page 1

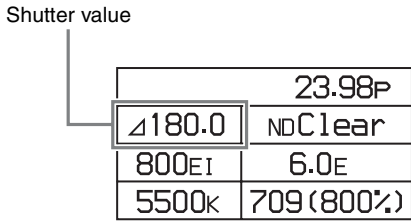

- 2 Select [Step], then press the MENU SEL/ENTER dial.

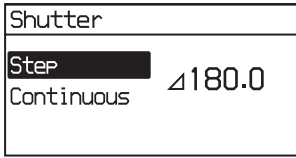

- 3 Turn the MENU SEL/ENTER dial to select the shutter value.

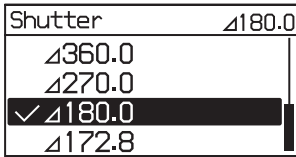

Pressing the MENU SEL/ENTER dial confirms the setting, and reflects the changed value on the camera. Pressing the BACK button cancels the shutter setting, and restores the previous value.

To set using the VF menu

Set on the <Shutter/FPS> page in the Camera menu (page 43).

Selecting an arbitrary shutter value

In Continuous mode, an arbitrary shutter value can be set.

- 1 Select the shutter value on settings page 1, then press the MENU SEL/ENTER dial.

Settings page 1

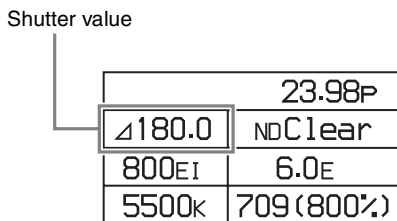

- 2 Select [Continuous], then press the MENU SEL/ENTER dial.

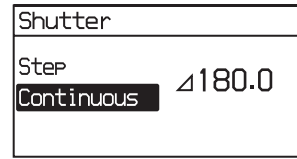

- 3 Turn the MENU SEL/ENTER dial to select the shutter value.

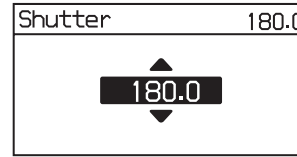

You do not need to press the MENU SEL/ENTER dial to set a value. The shutter value changes are reflected on the camera as the MENU SEL/ENTER dial is turned. Pressing the BACK button cancels the shutter setting, and restores the previous value.

To set using the VF menu

Set on the <Shutter/FPS> page in the Camera menu (page 43).

When not using the shutter

Press the E. button or M. button, whichever is lit, on the SHUTTER button for one second or longer. The shutter switches off and the light on both SHUTTER buttons go out.

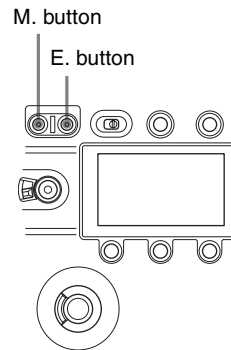

3-3-4 Selecting an ND Filter

The camera has built-in optical ND filters that can be used to match the illumination and natural lighting conditions. The following filters can be selected in F65RAW mode or HD mode. In F65RAW-HFR mode, the filter is fixed to Clear.

Filter density	Description
Clear	No filter is used.
0.9	1/8 optical transmittance

Filter density	Description
1.2	1/16 optical transmittance
1.5	1/32 optical transmittance
1.8	1/64 optical transmittance

- 1 Select the ND filter on settings page 1, and press the MENU SEL/ENTER dial.

Settings page 1

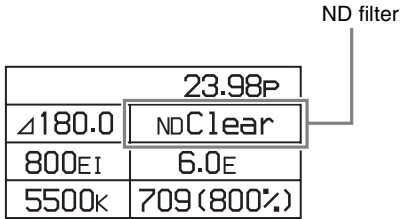

- 2 Turn the MENU SEL/ENTER dial to select the ND filter, then press the MENU SEL/ENTER dial.



To set using the VF menu

Set the ND Filter on the <Base Setting> page in the Camera menu (page 43).

3-3-5 Setting the Sensitivity (EI Value) (Cine Mode)

The sensitivity is determined by the EI value (Exposure Index). The viewfinder and monitor image brightness changes to match the EI value. But it has no affect on the recorded image.

The camera supports the following sensitivity settings: 200EI, 250EI, 320EI, 400EI, 500EI, 640EI, 800EI, 1000EI, 1250EI, 1600EI, 2000EI, 2500EI, and 3200EI.

- 1 Select the sensitivity on settings page 1, then press the MENU SEL/ENTER dial.

Settings page 1

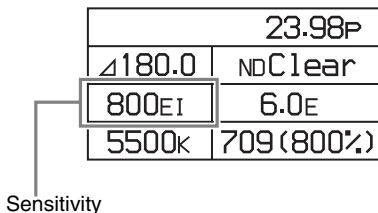

- 2 Turn the MENU SEL/ENTER dial to select the EI value, then press the MENU SEL/ENTER dial.

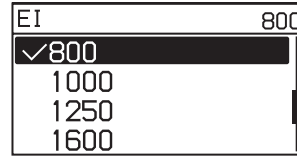

To set using the VF menu

Set the Exposure Index on the <Base Setting> page in the Camera menu (page 43).

3-3-6 Checking the Highlight Latitude (Cine Mode)

The highlight latitude can be checked on settings page 1 on the subdisplay.

The latitude is automatically assigned one of the following values, depending on the sensitivity setting.

Sensitivity (EI value)	Latitude
200EI	4.0E
250EI	4.4E
320EI	4.7E
400EI	5.0E
500EI	5.4E
640EI	5.7E
800EI	6.0E
1000EI	6.4E
1250EI	6.7E
1600EI	7.0E
2000EI	7.4E
2500EI	7.7E
3200EI	8.0E

The value is displayed in “xxEI” format and represents the highlight latitude displayed as a lens aperture value (f-stop) for key light from a gray chart with 18% reflectivity.

Settings page 1

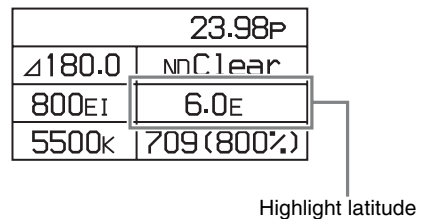

3-3-7 Setting the Color Temperature

The color temperature can be set to 3200K (tungsten), 4300K (tungsten), or 5500K (daylight) to match the shooting environment.

- 1 Select the color temperature on settings page 1, then press the MENU SEL/ENTER dial.

Settings page 1

23.98P	
Δ180.0	NDClear
800EI	6.0E
5500k	709 (800%)

Color temperature

- 2 Turn the MENU SEL/ENTER dial to select the color temperature, then press the MENU SEL/ENTER dial.

Color Temperature	5500K
3200k	
4300k	
✓5500k	

To set using the VF menu

Set the Color Temperature on the <Base Setting> page in the Camera menu (page 43).

3-3-8 Setting the SDI OUT Output LUT

The image output from the SDI OUT connectors is configured using a Look-up table (LUT). The images shot with the camera are intended for processing in post-production, and are not suitable for checking the results of shooting as-is on the scene. Setting a LUT changes the tone of the image displayed on a monitor connected to an SDI OUT connector, without affecting the main RAW image output, for ease of monitoring.

Setting	Description
Off	No LUT is configured.
709(800%) (default)	Outputs a signal that extends the dynamic range by up to 800% in video terms based on ITU-R709 with conventional monitor gamma.
S-Log2	Outputs a non-adjustable signal that uses S-Log gamma. Up to 1300% input light level can be reproduced.

Setting	Description
HG8009G40	Outputs a signal using hypergamma with 800% dynamic range, 109% white limit, and 40% video output for 18% gray card reflection.
HG8009G33	Outputs a signal using hypergamma with 800% dynamic range, 109% white limit, and 33% video output for 18% gray card reflection.
[User1] to [User5]	You can select an imported LUT, from up to five created using CVP File Editor, belonging to the group selected on the <LUT FILE> page in the VF menu.

- 1 Select the monitor look-up table on settings page 1, then press the MENU SEL/ENTER dial.

Settings page 1

23.98P	
Δ180.0	NDClear
800EI	6.0E
5500k	709 (800%)

LUT

- 2 Turn the MENU SEL/ENTER dial to select the look-up table to apply, then press the MENU SEL/ENTER dial.

LUT SEL	709 (800%)
✓709 (800%)	
S-Log2	
HG8009G40	
HG8009G33	

To set using the VF menu

Set on the <LUT> page in the VF/SDI menu (page 46).

3-3-9 Selecting the Fan Operating Mode

You can set the operating mode of the camera's built-in fans. The mode can be set to silence the fan speed noise or to provided maximum cooling to suit the shooting environment. You can select one of the following operating modes.

Setting	Fan operation
Auto1	The fans are automatically controlled according to the internal temperature, regardless of whether recording or not.
Auto2 (default)	The fans are automatically controlled according to the internal temperature. When recording, the fans are controlled to maintain quiet operation. ^{a)}
Min	In this mode, quiet fan operation is maintained regardless of whether recording or not. This is the best mode if recording for more than 30 minutes in a quiet environment, such as a concert hall. Use this mode in environments with ambient temperature of less than 30°C (86°F).
Max	Fan rotation set at the maximum speed to lower the internal temperature.

a) The coupling of the fan control with recording is available only when an SR-R4 is docked on the camera.

Note

Even when Min mode is selected, the speed of the fans automatically increases if the internal temperature rises.

- 1 Select the fan operating mode on settings page 2, then press the MENU SEL/ENTER dial.

Settings page 2

Fan operating mode

Reel No. 999	Fan Mode MAX
24.0V 10.8V	Remain 30min
TCG 00:00:00:00	

- 2 Turn the MENU SEL/ENTER dial to select the operating mode, then press the MENU SEL/ENTER dial.

Fan Mode	Max
Auto1	
Auto2	
Min	
✓Max	

To set using the VF menu

Set on the <Fan Mode> page in the Config menu (page 49).

3-3-10 Checking the Voltage

The voltage of the power supplies connected to the camera can be checked on settings page 2 on the subdisplay.

Settings page 2

Voltages

Reel No. 999	Fan Mode MAX
24.0V 10.8V	Remain 30min
TCG 00:00:00:00	

The voltage of the 24 V supply is displayed on the left, and the voltage of the 12 V supply on the right. If power is not supplied, “- -” is displayed.

If the voltage falls to the Near End level, the voltage indicator starts flashing. If the voltage falls to the End level, the indicator starts flashing rapidly.

The voltage Near End and End levels can be set on the <Battery Alarm> page in the Config menu (page 49).

For details, see “3-7-3 Setting the Voltage Warning Values” (page 38).

3-3-11 Checking the Remaining Media

When the SR-R4 recorder is docked with the camera, an estimate of the remaining recording time (recording units: minutes) on the memory card can be checked on settings page 2 on the subdisplay.

Settings page 2

Media remaining

Reel No. 999	Fan Mode MAX
24.0V 10.8V	Remain 30min
TCG 00:00:00:00	

3-3-12 Checking the Timecode

When the SR-R4 recorder is docked with the camera, the SR-R4 timecode can be checked on settings page 2 on the subdisplay.

Reel No. 999	Fan Mode MAX
24.0V 10.8V	Remain 30min
TCG 00:00:00:00	

Timecode

Time code display types

Indication	Meaning
TCG 00:00:00:00	Time code generator's time code data. DF or NDF is displayed, depending on the time code type.
TCR 00:00:00:00	LTC or VITC reader time code data. LTC or VITC is displayed on the right. Also, DF or NDF is displayed, depending on the time code type.
UBG 00 00 00 00	Time code generator's user bit data.
UBR 00 00 00 00	LTC or VITC reader user bit data. LTC or VITC is displayed on the right.
TM1 00:00:00:00	Timer1 timer value.
TM2 00:00:00:00	Timer2 timer value.

3-3-13 Assigning Functions to the ASSIGN Buttons

Separate functions can be assigned to each of the ASSIGN buttons 1 to 4 on the side of the camera body. The following functions are assigned to the buttons by factory default.

Button	Function
ASSIGN 1	Mag
ASSIGN 2	Mag Position
ASSIGN 3	Hi/Lo Key
ASSIGN 4	Rec Review

Functions that can be allocated to the ASSIGN buttons

Menu indication	Function
OFF	No function is allocated.
Mag	Displays a magnified image in the viewfinder and on the SDI OUT connectors. Each time the button is pressed, the magnification changes between 2-times, 4-times, and Off. When the magnification is 2-times or 4-times, the ASSIGN button allocated with the Mag function is lit. The display returns to normal after about 30 seconds.

Menu indication	Function
Mag Position	Selects the position of the image that is magnified by the Mag function. There are nine points on the screen that can act as the center point of the magnified image. This function sets the position of the magnified image as an area centered on one of these points. Each time the button is pressed, the area moves one position from top left to bottom right. When the display is magnified, the ASSIGN button allocated with the Mag Position function is lit.
Hi/Lo Key	Temporarily changes LUT for checking the high-luminance brightness and low-luminance darkness of the image in the viewfinder and from the SDI OUT connectors. Areas blown-out are displayed in red in Hi Key mode by setting Highlight Clip Indicator to On. The button toggles between high-luminance check (gain reduction), low-luminance check (gain amplification), and normal. The display returns to normal after about 30 seconds.
Fan Mode	Switches the fan operating mode. <i>For details on the fan operating mode, see "3-3-9 Selecting the Fan Operating Mode" (page 30).</i>
Rec Review	Plays the video just recorded. The playback interval (all or the last five seconds) follows the setting in the SR-R4 menu.
Bars	Outputs color bars. Can be assigned to ASSIGN 4 only.

- 1 Select AS1 to AS4 for the button you wish to assign on settings page 3, then press the MENU SEL/ENTER dial.

Settings page 3

ASSIGN buttons

AS1 Mag	AS2 Mag Position
AS3 OFF	AS4 OFF
Brightness 4	DIAGNOSIS OK

- 2 Turn the MENU SEL/ENTER dial to select the function to assign, then press the MENU SEL/ENTER dial.

AS1	Mag
✓ Mag	
Mag Position	
Hi/Lo Key	
Fan Mode	

To set using the VF menu

Set on the <Switch Assign> page in the Config menu (page 49).

3-3-14 Adjusting the Subdisplay Brightness

The brightness of the subdisplay can be adjusted to one of four levels.

- 1 Select Brightness on settings page 3, then press the MENU SEL/ENTER dial.

Settings page 3

AS1 Mag	AS2 Mag Position
AS3 OFF	AS4 OFF
Brightness 4	Diagnosis OK

Brightness

- 2 Turn the MENU SEL/ENTER dial to adjust the brightness, then press the MENU SEL/ENTER dial.

The higher the value, the brighter the subdisplay.



3-3-15 Checking the Self-Diagnostic Results

The results of self-diagnostics can be checked on settings page 3. If an internal error occurs, a warning or error message is displayed.

For details about messages, see “Warning/Error Messages” (page 58).

AS1 Mag	AS2 Mag Position
AS3 OFF	AS4 OFF
Brightness 4	Diagnosis OK

3-4 VF Menu Basic Operation

Detailed settings that cannot be configured on the subdisplay are set in the VF menu displayed in the viewfinder or on a monitor.

The VF MENU button, MENU SEL/ENTER dial, and BACK button on the side panel of the camera head are used to operate the VF menus.

The MENU SEL/ENTER dial has a knob that you turn to select items (MENU SEL) and a button you press to confirm values for items (ENTER).

Side panel of the camera head

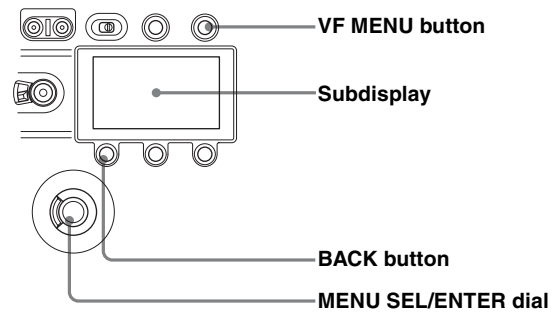

While the subdisplay is in Change mode, menu operations in the viewfinder or on a monitor cannot be performed.

For more information about settings on the subdisplay, see “3-3 Basic Settings using the Subdisplay” (page 25).

To display the settings screen

- 1 Press the VF MENU button.

The top menu screen appears. Categories are displayed on the left, and pages contained within that category are displayed on the right.

Top menu screen

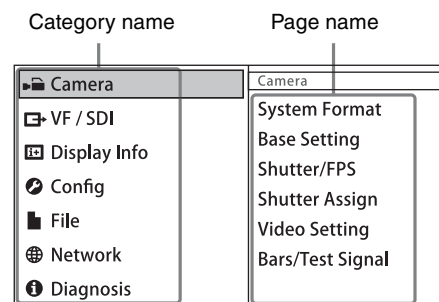

- Turn the MENU SEL/ENTER dial to select a category, then press the MENU SEL/ENTER dial.

The page select screen appears. Items within the selected page and the current values of those items are displayed. You can check the items and their values on each page by turning the MENU SEL/ENTER dial. Pressing the BACK button returns to the top menu screen.

Page select screen

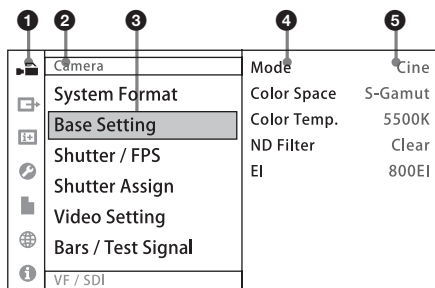

- Category icon
- Category name
- Page name
- Configuration item
- Current value

- Turn the MENU SEL/ENTER dial to select a page, then press the MENU SEL/ENTER dial.

The settings screen appears. Pressing the BACK button returns to the Page select screen.

Settings screen

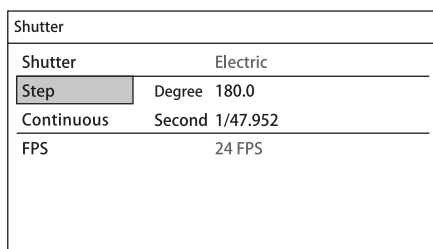

To change a setting

- Turn the MENU SEL/ENTER dial to move to the desired item.
 - Press the MENU SEL/ENTER dial.
- The list or spin box corresponding to the selected item is displayed.

Screen Example (List)

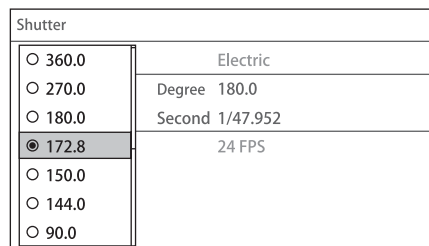

Screen Example (Spin box)

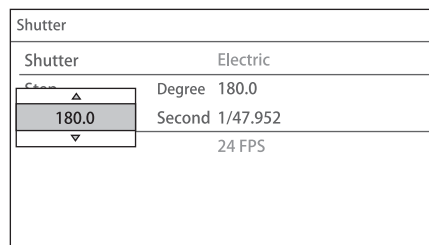

- Turn the MENU SEL/ENTER dial to select a value for the item.

To cancel a setting

Pressing the BACK button while the operating screen is displayed cancels the operation and restores the current value.

- Press the MENU SEL/ENTER dial to confirm the setting.

To enter a character string

You use a keyboard displayed on the screen to enter file names, passwords, and other text.

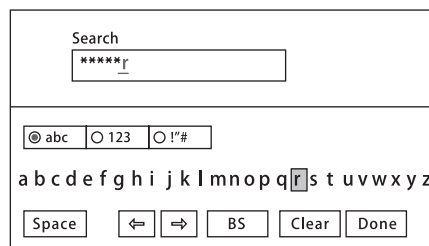

The string is displayed in the upper text box as you enter each character.

Turn the MENU SEL/ENTER dial to select the Done button, then press the MENU SEL/ENTER dial to confirm the entered character string.

To exit the menu

Press the VF MENU button.

3-5 Setting the Shooting Mode

The shooting mode can be set to RAW mode or HD mode. You select the mode on the <System Format> page of the Camera menu (page 43). You can also set the frame rate and the encoding on the <System Format> page.

<System Format> page

System Format	
RAW/HD	F65RAW
Frame Rate	23.98p
Signal Mode	— (HD Mode Only)
Bit Depth	— (HD Mode Only)
Encode	F65RAW-SQ
<input type="button" value="Set"/>	

RAW/HD

Selects the shooting mode.

F65RAW: Records 16-bit linear RAW data.

HD: Develops RAW data to HD internally, and records HD data.

F65RAW-HFR: 16-bit linear RAW data recorded at 120 fps (max.).

Notes

Observe the following points when using the unit with an SR-R4 mounted.

- If a frame rate setting with “ForPB” is set for Frame Rate, a gray screen is displayed when the camera is powered-on and the camera switches to video when you start playback.
- The viewfinder display cannot be magnified when playing back in F65RAW-HFR mode.

Frame Rate

Selects the frame rate. The frame rates that can be selected vary depending on the RAW/HD mode selection. For details about the frame rates that can be selected, see “3-3-2 Setting the Video Format” (page 26).

Signal Mode

Selects the signal format in HD mode. 4:4:4 RGB or 4:2:2 YCbCr can be selected.

Configurable in HD mode only.

Bit Depth

In HD mode, displays the number of recording bits.

“10bit” or “12bit” is automatically displayed according to the Encode setting.

When Encode is set to Lite or SQ, 10-bit recording is selected. When set to HQ, 12-bit recording is selected.

Encode

Selects the recording mode.

In F65RAW mode, “F65RAW-SQ” or “F65RAW-Lite” can be selected.

In HD mode, “SR-HQ” or “SR-SQ” can be selected when Signal Mode is set to 4:4:4 RGB, and “SR-SQ” or “SR-Lite” can be selected when Signal Mode is set to 4:2:2 YcbCr.

Not configurable in F65RAW-HFR mode.

To enable a setting

- 1 Select each parameter on the <System Format> page, select Set, and then press the MENU SEL/ENTER dial.
- 2 After confirming the setting in the confirmation dialog, select Execute, then press the MENU SEL/ENTER dial.

The settings are reflected on the camera.

3-6 Setting the Output Signal

3-6-1 Selecting the Output Video Signal

The type of video signals to be output on the SDI OUT and VF connectors can be selected. The settings are common to each connector.

You select the signal on the <VF/SDI Signal> page (page 47) in the VF/SDI menu.

Output signal when connected to SR-R4

The SR-R4 playback image is automatically output when playback is started on the SR-R4. When playback is stopped on the SR-R4, the output reverts to the camera image.

<VF/SDI Signal> page

VF/SDI Signal	
Effective Area	4096:2160
Color	Color
Scan Type (Over 30p)	Interlace
Image Invert Select	Off

Effective Area

Selects the output image.

4096:2160: Outputs the entire recorded image.

3840:2160: Outputs an image with 16:9 aspect ratio.

Anamorphic Unsqueeze x2: Outputs an undistorted image, with surplus areas, when using a 2x anamorphic lens.

Color

Selects the output channel.

Color: Outputs all RGB channels.

R: Outputs the R channel only.

G: Outputs the G channel only.

B: Outputs the B channel only.

Scan Type (Over 30p)

Selects whether to output images for reduced distortion of fast-moving subjects when Frame Rate is set to 50p or higher.

Interlace: Interlaced output at normal settings.

Frame Drop: Outputs signal with dropped frames to reduce the distortion of fast-moving subjects when Frame Rate is set to 50p or higher. Some motion smoothness is sacrificed in return for reduced distortion.

Image Invert Select

Selects the type of image inversion.

Off: No inversion

Vertical

Horizontal

Vertical & Horizontal

3-7 Viewing and Setting the Viewfinder Display

Besides the video image, the viewfinder can display text and messages showing the camera settings and operation status.

The same information can be displayed on a monitor connected to the SDI OUT connector.

3-7-1 Viewing the Basic Status Display

The following status information is displayed in the viewfinder when you press the VF DISPLAY button. The display status can be specified on the <Status1> and <Status2> pages in the Display Info menu (page 47).

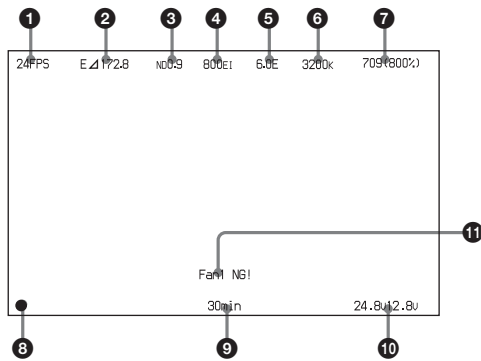

1 Frame rate

Displays the current frame rate.

2 Shutter angle

Displays the shutter value as a shutter angle. When using an electronic shutter, “E” is displayed before the angle. When using a mechanical rotary shutter, “R” is displayed.

3 ND filter

Displays the type of ND filter currently selected.

4 Sensitivity

Displays the currently set sensitivity as an EI value.

5 Highlight latitude

Displays the latitude for highlights relative to an 18% gray chart.

6 Color temperature filter mode

Indicates the state of the electrical filter.

7 Look-up table (LUT)

Displays the file name of the look-up table currently selected.

8 Recording status indicator

Displays “●” when the SR-R4 docked on the camera is recording.

9 Media remaining

Displays the approximate number of minutes remaining for the recording media in the SR-R4 docked on the camera.

10 Power supply voltages

Displays the state of the output voltages. The output from DC 24 V OUT is displayed on the left, and DC 12 V OUT on the right.

The voltage readout begins to flash if the corresponding input voltage falls to the Near End value specified on the <Battery Alarm> page in the Config menu. The indicator flashes more rapidly if the voltage falls to the End value.

11 Message area

Displays a warning/error message if an error occurs. The error details are also displayed in the self diagnostics field in settings page 3 on the subdisplay.

For details about messages, see “Warning/Error Messages” (page 58).

3-7-2 Setting the Marker Display

Various markers can be displayed in the viewfinder and on the monitor.

Turning status/marker display On/Off for each output

You can set whether to display status information and markers in the signal output from the VF and SDI OUT connectors on the <Mix> page in the Display Info menu (page 47).

<Mix> page

Mix		
[Status/Menu]	VF	On
	SDI	On
[Marker]	VF	On
	SDI	On
	Color	White
	Brightness	7

The default setting is to display status information and markers in the signals from the VF and SDI OUT connectors.

Item	Setting
[Status/Menu] VF	Sets whether to display status information in the VF connector signal.
SDI	Sets whether to display status information in the SDI OUT connector signal.
[Marker] VF	Sets whether to display markers in the VF connector signal.
SDI	Sets whether to display markers in the SDI OUT connector signal.
Color	Sets the display color of markers.
Brightness	Sets the marker display brightness in the range 1 to 10 (maximum brightness is 10).

Specifying the markers to display

When the marker display is turned On on the <Mix> page, you select the markers for display on the <Marker> page in the Display Info menu.

<Marker> page

Marker	
Center	Off
Effective	Off
Aspect Ratio	2.39:1
Width	—
Height	—

The default setting for all markers is “Off.”

Item	Setting
Center Marker	Sets whether to display the center marker.
Effective	Sets whether to display the effective pixel area.
Aspect Ratio	Selects the aspect ratio when Effective is set to On. The following options are available. 2.39:1, 2.35:1, 1.90:1, 1.85:1, 1.78:1, 1.66:1, 1.33:1, Variable* * When Variable is selected, the displayed aspect ratio is determined by the Width and Height settings. Example: Variable (1.78:1).
Width	Specifies the width of the effective pixel area (960 to 1920 pixels) when Aspect Ratio is set to Variable.
Height	Specifies the height of the effective pixel area (540 to 1080 pixels) when Aspect Ratio is set to Variable.

3-7-3 Setting the Voltage Warning Values

The Near End and End values used to issue battery voltage warnings when the supply voltage drops are set on the <Battery Alarm> page in the Config menu.

Two Near End and End values can be saved, and you can switch between them as required.

<Battery Alarm> page

Battery Alarm	
DC IN (24V) Type	Type1
Near End	22.2 V
End	21.6 V
DC IN (12V) Type	Type1
Near End	11.1 V
End	10.8 V

Item	Setting
DC IN (24V) Type	Selects the 24 V system supply settings. You can set Near End and End threshold values for both Type1 and Type2.
Near End	Sets the 24 V power supply Near End value (20.5 V to 30.0 V). The default is 22.2 V.
End	Sets the 24 V power supply End value (20.0 V to 24.0 V). The default is 21.6 V.
DC IN (12V) Type	Selects the 12 V system supply settings. You can set Near End and End threshold values for both Type1 and Type2.
Near End	Sets the 12 V power supply Near End value (11.0 V to 17.0 V). The default is 11.1 V.
End	Sets the 12 V power supply End value (10.5 V to 14.0 V). The default is 10.8 V.

3-7-4 Magnifying the Viewfinder Display

The image displayed in the viewfinder can be magnified by assigning the Mag function to an ASSIGN button. The magnification changes between 2-times, 4-times, and Off each time the ASSIGN button is pressed.

The position of the magnified image displayed in the viewfinder can be adjusted by assigning the Mag Position function to another ASSIGN button. The position of the magnified image moves one step from top left to bottom right each time the ASSIGN button is pressed.

Notes

- The magnified display returns to normal 30 seconds after pressing the ASSIGN button. Also, the display returns to normal when power is applied and when recording starts.
- If the image is magnified by 4 when using the Anamorphic Unsqueeze x2 function, the image is magnified in the vertical dimension by 4, but the horizontal dimension remains magnified by 2.

When the image is magnified, the following information is displayed in the viewfinder.

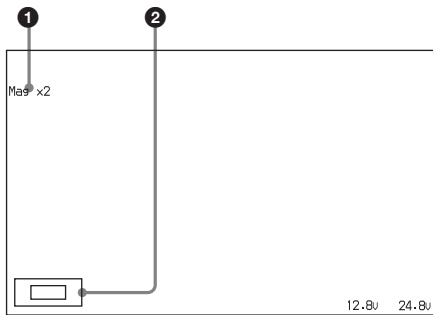

1 Magnification

When the image is magnified by 2, "Mag x 2" is displayed; when magnified by 4, "Mag x 4" is displayed.

2 Magnification position

Displays the position of the magnified image.

3-8 Restoring the factory default settings

Settings can be restored to their factory default values by executing the Gamma File Preset, LUT File Preset, and All File Preset commands on the <File Preset> page in the File menu (*page 51*), and the Preset command on the <Network Reset> page in the Network menu (*page 52*).

Execute the All File Preset command after upgrading software or replacing boards.

<File Preset> page

File Preset	
Gamma File Preset	Reset
LUT File Preset	Reset
All File Preset	Reset

4-1 Subdisplay Menu List

This section describes the menu list displayed on the subdisplay.

Item		Default	Set or display value	Remarks
Settings page 1				
Video format	FPS	N/A	S59.98p, S60p: 1 to 60 S119.88p, S120p: 1 to 120	
	Frame rate	23.98p	F65RAW mode: 23.98p, 24p, 29.97p, 25p, 50p, 59.94p, S59.94p (23.98p), S59.94p (29.97p), S60p (24p), S60p (25p) HD mode (4:4:4 RGB): 23.98p, 29.97p, 24p, 25p, S59.94p (23.98p), S59.94p (29.97p), S60p (24p), S60p (25p) HD mode (4:2:2 YcbCr): 23.98p, 29.97p, 24p, 25p, 50p, 59.94p, S59.94p (23.98p), S59.94p (29.97p), S60p (24p), S60p (25p) F65RAW-HFR mode: 23.98pForPB, 29.97pForPB, 24pForPB, 25pForPB, S119.88p (23.98p), S119.88p (29.97p), S120p (24p), S120p (25p)	
Electronic shutter		180.0	Step: 11.2, 22.5, 45.0, 90.0, 144.0, 150.0, 172.8, 180.0, 270.0, 360.0 Continuous: 4.2 to 360.0	
Mechanical rotary shutter		180.0	Step: 11.2, 22.5, 45.0, 90.0, 144.0, 150.0, 172.8, 180.0 Continuous: 11.2 to 180.0	Cannot be used in F65RAW-HFR mode.

Item	Default	Set or display value	Remarks
ND filter	Clear	F65RAW mode, HD mode: Clear, 0.9, 1.2, 1.5, 1.8, Close, Mainte F65RAW-HFR mode: Clear(HFR), Close, Mainte	Close: Filter closed (display only) Mainte: Maintenance mode, with no filter deployed (display only). Switched using the VF menu.
Sensitivity (Cine mode: EI value, Custom mode: dB value)	Cine mode: 800EI Custom mode: 0dB	Cine mode: 200EI, 250EI, 320EI, 400EI, 500EI, 640EI, 800EI, 1000EI, 1250EI, 1600EI, 2000EI, 2500EI, 3200EI Custom mode: -6dB, -3dB, 0dB, 3dB, 6dB, 9dB, 12dB	
Highlight latitude (display only)	6.0E	Cine mode: 4.0E, 4.4E, 4.7E, 5.0E, 5.4E, 5.7E, 6.0E, 6.4E, 6.7E, 7.0E, 7.4E, 7.7E, 8.0E Custom mode: 6.0E (12dB to 0dB), 5.5E (-3dB), 5.0E (-6dB)	Automatically changes according to the sensitivity setting.
Color temperature	5500K	3200K, 4300K, 5500K	
LUT	709(800%)	Off, 709(800%), S-Log2, HG8009G40, HG8009G33, [User1], [User2], [User3], [User4], [User5]	The data name is displayed for [User1] to [User5]
Settings page 2			
Reel number	N/A	1 to 999, --	
Fan operating mode	Auto2	Auto1, Auto2, Min, Max	
Voltage (display only)	N/A	0.1 V increments	Displays the voltages of the 12 V and 24 V system power supplies.
Media remaining (display only)	N/A	0 to 999min, --min, FULL, 16h to 999h	Displays the remaining recording time for SR-R4 media.
Timecode (display only)	N/A	TCG, TCR, UBG, UBR, TM1, TM2	Displays the SR-R4 timecode.
Settings page 3			
ASSIGN button 1	Mag	Mag, Mag Position, Hi/Lo Key, Fan Mode, Rec Review, Off	
ASSIGN button 2	Mag Position		
ASSIGN button 3	Hi/Lo Key		
ASSIGN button 4	Rec Review	Mag, Mag Position, Hi/Lo Key, Fan Mode, Rec Review, Bars, Off	
Subdisplay brightness	4	1 to 4	
Self diagnostics (display only)	N/A	OK, Warning/error message	Displays self-diagnostics results. A message is displayed if an error occurs. <i>For details, see "Warning/Error Messages" (page 58).</i>

4-2 VF Menu List

This section describes the VF menu items displayed in the viewfinder or on a monitor.

Note

The items displayed in a web browser or on a tablet device are basically the same as the VF menu, with one exception. The item not displayed on these devices is noted in the following table.

The VF menu has the following structure.

Menu	Setting
Camera	Sets the camera's basic functions and image recording settings.
VF/SDI	Sets the monitor signal settings for output on the VF and SDI OUT connectors.
Display Info	Sets the display of status information and marker display in the viewfinder and on a monitor.
Config	Sets the ASSIGN buttons, warning voltage values, and cameras settings not related to output image signals.
File	Restores the menu settings to their factory default values.
Network	Sets wired/wireless LAN networks settings for connecting a camera. Not displayed in web browsers or on tablet devices.
Diagnosis	Displays self-diagnostics information.

4-2-1 Camera Menu

Page	Configuration item	Default	Settings	Remarks
<System Format> Signal format settings	RAW/HD	F65RAW	F65RAW, HD, F65RAW-HFR	Sets the recording mode.
	Frame Rate	23.98p	F65RAW mode: 23.98p, 24p, 29.97p, 25p, 50p, 59.94p, S59.94p (23.98p), S59.94p (29.97p), S60p (24p), S60p (25p) HD mode (4:4:4 RGB): 23.98p, 29.97p, 24p, 25p, S59.94p (23.98p), S59.94p (29.97p), S60p (24p), S60p (25p) HD mode (4:2:2 YcbCr): 23.98p, 29.97p, 24p, 25p, 50p, 59.94p, S59.94p (23.98p), S59.94p (29.97p), S60p (24p), S60p (25p) F65RAW-HFR mode: 23.98pForPB, 29.97pForPB, 24pForPB, 25pForPB, S119.88p (23.98p), S119.88p (29.97p), S120p (24p), S120p (25p)	Sets the frame rate.
	Signal Mode	4:4:4 RGB	4:4:4 RGB, 4:2:2 YCbCr	Selects the recording signal format in HD mode.
	Bit Depth	10bit	10bit, 12bit	In HD mode, displays the number of recording bits (Display only).
	Encode	F65RAW-SQ	F65RAW mode: F65RAW-SQ, F65RAW-Lite HD mode (4:4:4 RGB): SR-SQ, SR-HQ HD mode (4:2:2 YcbCr): SR-SQ, SR-Lite F65RAW-HFR mode: F65RAW-HFR (display only)	Selects the recording mode.
Set	--	Execute by Enter.		

Page	Configuration item	Default	Settings	Remarks
<Base Setting> Basic settings	Shoot Mode	Cine	Cine, Custom	
	Color Space	S-Gamut	S-Gamut, F900	Selects the colors reproducibility. It is fixed to S-Gamut in F65RAW mode. S-Gamut: This mode enables recording with wide color space comparable to film cameras. F900: This mode enables color reproduction equivalent to conventional cameras.
	Color Temperature	5500K	3200K, 4300K, 5500K	3200K, 4300K: Tungsten 5500K: Daylight
	ND Filter	Clear	F65RAW mode/HD mode: Clear, 0.9, 1.2, 1.5, 1.8, Close, Maintenance F65RAW-HFR mode: Clear(HFR), Close, Maintenance	Clear: No filter is used. 0.9: 1/8 optical transmittance 1.2: 1/16 optical transmittance 1.5: 1/32 optical transmittance 1.8: 1/64 optical transmittance Close: Filter closed (Display only) Maintenance: Maintenance mode, with no filter deployed.
	Exposure Index	800EI	200EI, 250EI, 320EI, 400EI, 500EI, 640EI, 800EI, 1000EI, 1250EI, 1600EI, 2000EI, 2500EI, 3200EI	Sets the sensitivity as an EI value (Cine mode only).
	Master Gain	0dB	-6dB, -3dB, 0dB, +3dB, +6dB, +9dB, +12dB	Sets the sensitivity using dB values (Custom mode only).
	Highlight Latitude	6.0E	Cine mode: 4.0E, 4.4E, 4.7E, 5.0E, 5.4E, 5.7E, 6.0E, 6.4E, 6.7E, 7.0E, 7.4E, 7.7E, 8.0E Custom mode: In HD mode with Gamma set to S-Log2, F65RAW mode, or F65RAW-HFR mode: 5.0E, 5.5E, 6.0E In HD mode with Gamma set to HG8009G40 or HG8009G33: 5.0E, 5.3E Gamma=User1 to User5: --	Display only. Display changes in response to sensitivity (<i>page 29</i>).
<Shutter/FPS> Shutter settings	Shutter	Electronic	Electronic, M-Rotary, Off	Displays the currently selected shutter.
	Degree	180.0	--	Displays the shutter angle (4.2 to 360.0). (Display only)
	Second	1/47.952	--	Displays the aperture time (Display only).
	Step	180.0	360.0, 270.0, 180.0, 172.8, 150.0, 144.0, 90.0, 45.0, 22.5, 11.2	Changes the shutter value in step mode. 360.0 and 270.0 are available for electronic shutter only.
	Continuous	180.0	4.2 to 360.0 (Electronic) 11.2 to 180.0 (M. Rotary)	Changes the shutter value in continuous variable mode.
	FPS	--	1 to 120 (Electronic) 8 to 60 (M. Rotary)	Sets the number of frames shot per second when Select FPS format is selected.

Page	Configuration item	Default	Settings	Remarks
<Shutter Assign> Shutter step settings	Step 1	360.0	4.2 to 360.0	Registers the shutter angles for each step.
	Step 2	270.0		
	Step 3	180.0		
	Step 4	172.8		
	Step 5	150.0		
	Step 6	144.0		
	Step 7	90.0		
	Step 8	45.0		
	Step 9	22.5		
	Step 10	11.2		
	Add	--	Execute by Enter.	Adds a shutter step value.
	Delete	--	Execute by Enter.	Deletes a shutter step value.
	Preset	--	Execute by Enter.	Restores the shutter step values to factory default values.
<Video Setting> Video settings	Gamma Category	Special	Hyper, Special, User	Selects the gamma category (HD mode only).
	Table	1:S-Log2	Hyper category: 7:HG8009G40 8:HG8009G33 Special category: 1:S-Log2 User category: 1:709(800%)	Specifies the specific table for the selected gamma category (HD mode only). For User category, tables can be created for [User1] to [User5] using CVP File Editor and then imported. The "1:709(800%)" table is overwritten if a user-defined table is imported.
	White	--	--	Adjusts the gain of the main line signal (Custom mode only).
	R	0	-256 to 255	
	G	0	-256 to 255	
	B	0	-256 to 255	
	Black	--	--	
	Master	0	-256 to 255	
	R	0	-256 to 255	
	G	0	-256 to 255	
	B	0	-256 to 255	
<Bars/Test Signal> Color bar and test signal settings	Color Bar	Off	On, Off	Turns the output of color bars On/Off.
	Test Signal	Off	Off, Saw, Step	Sets the test waveform output.

4-2-2 VF/SDI Menu

Page	Configuration item	Default	Settings	Remarks
<VF/SDI Tone & Color> LUT, ICT, and color space settings	LUT/ASC CDL	On	On, Off	Sets whether to apply an LUT or ASC CDL (LUT can be applied in HD mode when Gamma is set to Special, F65RAW mode, or F65RAW-HFR mode only).
	Select	709(800%)	709(800%), S-Log2, HG8009G40, HG8009G33, [User1], [User2], [User3], [User4], [User5]	Selects the LUT (HD mode when Gamma is set to Special, F65RAW mode, or F65RAW-HFR mode only). 709(800%): Signal with 800% dynamic range relative to ITU-R709. S-Log2: Unprocessed signal for post production color grading. Can reproduce up to 1300% of the input level. HG8009G40: Hypergamma signal with 800% dynamic range, 109% white limit, and 40% video output 18% gray card reflection. HG8009G33: Hypergamma signal with 800% dynamic range, 109% white limit, and 33% video output 18% gray card reflection. [User1] to [User5]: Imported LUT signal created using CVP File Editor.
	Color Space	ITU-R BT.709	Camera menu > Base Setting > Color Space: S-Gamut S-Gamut, ITU-R BT.709, F900 Camera menu > Base Setting > Color Space: F900 ITU-R BT.709, F900	Sets the color space for VF/SDI output. S-Gamut: Wide color space comparable with film cameras. F900: Color space equivalent to conventional cameras ITU-R BT709: Color space equivalent to ITU-R BT709
<ASC CDL> ASC CDL settings	ASC CDL	Off	On, Off	Adjusts the ASC CDL parameters. To adjust ASC CDL parameters in HD mode, set Gamma to S-Log2.
	ICT/LUT	--	--	Displays the LUT or ASC CDL selected using LUT/ASC CDL Select.
	Slope			Adjusts the individual R, G, B values of the ASC CDL slope function.
	R	1.000	0.000 to 3.999	
	G	1.000	0.000 to 3.999	
	B	1.000	0.000 to 3.999	
	Offset	--	--	Adjusts the individual R, G, B values of the ASC CDL offset function.
	R	0.000	-1.000 to 0.999	
	G	0.000	-1.000 to 0.999	
	B	0.000	-1.000 to 0.999	
	Power	--	--	Adjusts the individual R, G, B values of the ASC CDL power function.
	R	1.000	0.700 to 1.200	
	G	1.000	0.700 to 1.200	
B	1.000	0.700 to 1.200		
Saturation	1.000	0.000 to 2.000		Adjusts the value of the ASC CDL saturation function.

Page	Configuration item	Default	Settings	Remarks
<VF/SDI Signal> Output signal settings	Effective Area	4096:2160	4096:2160, 3840:2160, Anamorphic Unsqueeze x2	Selects the video for output (F65RAW, F65RAW-HFR only).
	Color	Color	Color, R, G, B	Selects the output RGB channels.
	Scan Type (Over 30p)	Interlace	Interlace, Frame Drop	Selects whether to output video with reduced distortion of fast-moving subjects when Frame Rate is set to 50p or higher.
	Image Invert Select	Off	Off, Vertical, Horizontal, Vertical & Horizontal	Selects the type of image inversion. Off: No image inversion Vertical: Top to bottom Horizontal: Left to right Vertical & Horizontal: Top to bottom and left to right

4-2-3 Display Info Menu

Page	Configuration item	Default	Settings	Remarks
<Exposure Assist> Exposure assistant function settings	Highlight Clip Indicator(Hi-Key)	Off	On, Off	Selects whether to enable the false color correction function for blown-out highlight areas when Gamma is set to Hi-Key.
<Mix> Status, marker display settings	[Status/Menu] VF	On	On, Off	Displays the status/menu in the viewfinder.
	SDI	On	On, Off	Displays the status/menu on the monitor.
	[Marker] VF	On	On, Off	Displays markers in the viewfinder.
	SDI	On	On, Off	Displays markers on the monitor.
	Color	White	White, Yellow, Cyan, Green, Magenta, Red, Blue	Sets the display color of markers.
	Brightness	7	1 to 10	Adjusts the brightness of the marker display.
<Status1> Status indicator display item settings	FPS	Off	On, Off	Turns the frame rate display On/Off.
	ND Filter	Off	On, Off	Turns the ND filter display On/Off.
	Color Temperature	Off	On, Off	Turns the color temperature display On/Off.
	EI/Master Gain	Off	On, Off	Turns the EI value display On/Off.
	Shutter	Off	On, Off	Turns the shutter operation status display On/Off.
	Media Remain	Off	On, Off	Turns the media remaining display On/Off.



Page	Configuration item	Default	Settings	Remarks
<Status2> Status indicator display item settings	Battery DC IN 12V	Off	On, Off	Turns the 12 V supply voltage display On/Off.
	Battery DC IN 24V	Off	On, Off	Turns the 24V supply voltage display On/Off.
	Message	On	On, Off	Turns the message display On/Off.
	LUT	On	On, Off	Turns the LUT file name display On/Off.
	Hi/Lo Key	On	On, Off	Sets whether to enable/disable the Hi/Lo Key function assigned to an assignable switch.
	Rec	On	On, Off	Turns the recording indicator On/Off.
<Marker> Marker indicator display item settings	Center	Off	On, Off	Turns the center marker On/Off.
	Effective	Off	On, Off	Turns the effective pixel area marker display On/Off.
	Aspect Ratio	2.39:1	2.39:1, 2.35:1, 1.90:1, 1.85:1, 1.78:1, 1.66:1, 1.33:1, Variable	Sets the aspect ratio when Effective is set to On. Displays "Variable (Width/Height:1)" ratio when Aspect Ratio is set to Variable.
	Width	960	960 to 1920	Specifies the width of the effective pixel area when Aspect Ratio is set to Variable.
	Height	540	540 to 1080	Specifies the height of the effective pixel area when Aspect Ratio is set to Variable.

4-2-4 Config Menu

Page	Configuration item	Default	Settings	Remarks
<Switch Assign> ASSIGN button function assignment	Assign 1	Mag	Off, Mag, Mag Position, Hi/Lo Key, Fan Mode, Rec Review	<p>Off: No function is allocated.</p> <p>Mag: Displays a magnified image in the viewfinder and on the SDI OUT connectors.</p> <p>Each time the button is pressed, the magnification changes between 2-times, 4-times, and Off. When the magnification is 2-times or 4-times, the ASSIGN button allocated with the Mag function is lit.</p> <p>Mag Position: Selects the position of the image that is magnified by the Mag function.</p> <p>Each time the button is pressed, the position moves from top left to bottom right. When the display is magnified, the ASSIGN button allocated with the Mag Position function is lit.</p> <p>Hi/Lo Key: Temporarily changes LUT for checking the high-luminance brightness and low-luminance darkness of the image in the viewfinder and from the SDI OUT connectors. The button toggles between high-luminance check (gain reduction), low-luminance check (gain amplification), and normal.</p> <p>Fan Mode: Switches the fan operating mode. For details on the fan operating mode, see "3-3-9 Selecting the Fan Operating Mode" (page 30).</p> <p>Rec Review: Plays the video just recorded.</p> <p>Bars: Outputs color bars.</p>
	Assign 2	Mag Position		
	Assign 3	Hi/Lo Key		
	Assign 4	Rec Review	Off, Mag, Mag Position, Hi/Lo Key, Fan Mode, Rec Review, Bars	
<Slate Data> Slate information display	Reel*	--	--	<p>Displays information specified on the "Slate" page of the F65Remote (excluding Reel, Camera Index, Shot).</p> <p>* For Reel, Camera Index, Shot: Displays information specified on the SR-R4.</p>
	Scene	--	--	
	Take	--	--	
	Camera Index*	--	--	
	Cut	--	--	
	Shot*	--	--	
	Project	--	--	
	Production	--	--	
	Director Name	--	--	
	Director of Photography Name	--	--	
	Description	--	--	
	Next	--	Execute by ENTER.	Moves to next page.
	Back	--	Execute by ENTER.	Moves to previous page.
	Clear	--	Cancel/OK Execute by ENTER.	Clears the items (excluding Reel, Camera Index, Shot).

Page	Configuration item	Default	Settings	Remarks
<Fan Mode> Fan operating mode select	Fan Mode	Auto2	Auto1, Auto2, Min, Max	Auto1: Automatic control, according to the internal temperature. Auto2: Automatic control, according to the internal temperature, and maintains quiet operation when recording. Min: Quiet mode, without synchronization with recording (can be used at ambient temperatures of less than 30°C (86°F)). Max: High-speed mode, fan rotates at maximum speed.
<Date/Hour Meter> Date/Time settings and accumulated ON time display	Date	--	yyyy/mm/dd	Sets the current date.
	Time	--	hh:mm	Sets the current time.
	Hour Meter	--	0H to 99999H	Displays the accumulated powered-ON time since reset from the Service menu.
	Date Type	Y/Mn/D	Y/Mn/D, Mn/D	Selects the date display format.
<Sync> Sync signal settings	Genlock			
	Input Signal	HD-Y	HD-Y, HD-SDI	Selects the input connector for the external sync signal. The genlock signal must be reapplied after modifying this setting. HD-Y: HD 3-level sync HD-SDI: HD-SDI input
	Status	--	Locked, Not Locked, No Signal	Display only. Locked: Synchronized successfully. Not Locked: Not synchronized. No Signal: There is no input signal.
<Battery Alarm> Supply voltage settings	DC IN (24V) Type	Type1	Type1, Type2	Selects the 24 V system supply settings.
	Near End	22.2 V	20.5 V to 30.0 V	Sets the power supply voltage drop warning level for the 24 V supply.
	End	21.6 V	20.0 V to 24.0 V	Sets the power supply exhausted warning level for the 24 V supply.
	DC IN (12V) Type	Type1	Type1, Type2	Selects the 12 V system supply settings.
	Near End	11.1 V	11.0 V to 17.0 V	Sets the power supply voltage drop warning level for the 12 V supply.
	End	10.8 V	10.5 V to 14.0 V	Sets the power supply exhausted warning level for the 12 V supply.

4-2-5 File Menu

Page	Configuration item	Default	Settings	Remarks
<Gamma File> Gamma file settings	1			Sets imported user gamma file created using CVP File Editor. A preset value of 709(800%) gamma is stored in configuration item 1 as the default gamma value. A user gamma file can be imported, overwriting the preset value. This value is selected when Gamma File Preset is executed on the <File Preset> page. Importing a gamma file stores all gamma data within the camera and is user-selectable.
	Name	709(800%)	(Up to 12 characters), --	
	Comment	Preset entry		
	2			
	Name	--	(Up to 12 characters), --	
	Comment	--		
	3			
	Name	--	(Up to 12 characters), --	
	Comment	--		
	4			
	Name	--	(Up to 12 characters), --	
	Comment	--		
	5			
	Name	--	(Up to 12 characters), --	
Comment	--			
Import	--	Execute by Enter.	Imports gamma file created using CVP File Editor (up to five) from USB flash memory or SD memory card.	
<LUT File> LUT file settings	Group	--	(Up to 12 characters)	Displays the group name, with the LUT data settings belonging to the group displayed in Data. The group name and LUT data grouping reflect objects edited using CVP File Editor.
	Data	--		Displays the names of the imported user LUTs in a list. Selecting an item enables the LUT data settings (up to five) belonging to the same group for selection using ICT Select on the <VF/SDI Tone Setting> page and from the subdisplay of the camera.
	Import		Execute by Enter.	Imports LUT files created using CVP File Editor for up to twenty groups. Up to five LUT data settings can be created and imported for each group, for a total of 100 LUT data settings. When a LUT data setting is selected, all LUT data settings within the selected group are stored in the camera and can be selected.

Page	Configuration item	Default	Settings	Remarks
<All File> Configuration file import/export	Import	--	Execute by Enter.	Imports the settings of all menu parameters (excluding the following) from a configuration file. <ul style="list-style-type: none"> All Network menu items <Date/Hour Meter> in the Config menu Gamma File and LUT File in the File menu
	Export	--	Execute by Enter.	Exports the settings of all menu parameters (excluding the following) to a configuration file. <ul style="list-style-type: none"> All Network menu items <Date/Hour Meter> in the Config menu Gamma File and LUT File in the File menu
<File Preset> Restore settings to factory default	Gamma File Preset	--	Execute by Enter.	Deletes all gamma files created using CVP File Editor, and restores the factory default setting.
	LUT File Preset	--	Execute by Enter.	Deletes all LUT files created using CVP File Editor, and restores the factory default setting.
	All File Preset	--	Execute by Enter.	Restores all settings (excluding the following) to the factory default values. <ul style="list-style-type: none"> All Network menu items <Date/Hour Meter> in the Config menu Gamma File and LUT File in the File menu
<Media Format> Formatting media	M.S./SD Format	--	Execute by Enter.	Initializes the media and creates folders for the F65.

4-2-6 Network Menu

This menu is not displayed in web browsers or on tablet devices.

Page	Configuration item	Default	Settings	Remarks
<LAN Setting> IP address settings	DHCP	Disabled	Enabled, Disabled	Sets whether to automatically obtain an IP address from a DHCP server.
	IP Address	192.168.1.1	0.0.0.0 to 255.255.255.255	If DHCP is enabled, displays the IP address obtained from the DHCP server.
	Subnet Mask	255.255.255.0	0.0.0.0 to 255.255.255.255	
	Default Gateway	0.0.0.0	0.0.0.0 to 255.255.255.255	
	Set	--	Execute by Enter.	

Page	Configuration item	Default	Settings	Remarks
<Wi-Fi Setting> Wi-Fi settings	Wi-Fi	Disabled	Enabled, Disabled	Enables/disables the Wi-Fi settings. Enable for connection.
	Wi-Fi Status	No connectivity	Excellent, Good, Weak, No connectivity	Displays the communication/connection status.
	SSID	(Blank)	(Blank), String of up to 32 characters	Displays the network name.
	Network Type	--	Infra, ad-hoc	Displays the network connection mode.
	IP Address	--	0.0.0.0 to 255.255.255.255	Displays the value obtained from the DHCP server.
	Subnet Mask	--	0.0.0.0 to 255.255.255.255	
	Default Gateway	--	0.0.0.0 to 255.255.255.255	
	Scan Network	--	Execute by Enter.	Scans the network access point.
	Connect Manually	--	Execute by Enter.	Used to enter the network access point.
	ad-hoc Setting	--	Execute by Enter.	Configures ad-hoc network mode.
	SSID	(Blank)	(Blank), String of up to 32 characters	Sets the network name. Displayed only when Scan Network is executed.
	Network Type	Infra	Infra, ad-hoc	Displays the connection mode.
	Authentication	WPA2PSK	Infra: WPA2PSK, WPA2PSK ad-hoc: OPEN, SHARED	Sets the network authentication method. Displayed only when Scan Network is executed.
	Encryption	AES	Infra: TKIP, AES ad-hoc: WEP	Sets the data encryption method. Displayed only when Scan Network is executed.
	WEP Key Index	1	1, 2, 3, 4	Selects the WEP key index number when using ad-hoc mode.
	Input Select	ASCII8-63	ASCII8-63, HEX64, ASCII5, ASCII13, HEX10, HEX26	Selects the network encryption key format. ASCII8-63: 63 characters in 8-bit ASCII format. HEX64: 64 digits in hexadecimal format. ASCII5: 5 characters in ASCII format. ASCII13: 13 characters in ASCII format. HEX10: 10 digits in hexadecimal format. HEX26: 26 digits in hexadecimal format. ASCII5, ASCII13, HEX10, and HEX26 are valid only in ad-hoc mode.
	Key	(Blank)	63-character ASCII or 64-digit hexadecimal	Sets the network encryption key.
Set	--	Execute by Enter.		
<Remote Setting> Remote control settings	Access Password	Disabled	Enabled, Disabled	Sets access permissions for remote control over a network.
		sonyf65	(Blank), String of up to 32 characters	Sets the password for access via a network.
<Network Reset> Network settings reset	Network Settings	--	Execute by Enter.	Resets the network settings.

4-2-7 Diagnosis Menu

Page	Configuration item	Default	Settings	Remarks
<Version> Version information display	System	--	V X.xx	Displays the version of the system, ICs, and software.
	DIF1 PLD	--	V X.xxy-yy	
	DIF1 CPU	--	V X.xxy-yy	
	DIF2 PLD	--	V X.xxy-yy	
	DIF2 CPU	--	V X.xxy-yy	
	DIF3 PLD	--	V X.xxy-yy	
	DIF3 CPU	--	V X.xxy-yy	
	DIF_CONF	--	V X.xxy-yy	
	VDA PLD	--	V X.xxy-yy	
	VDA_CONF	--	V X.xxy-yy	
	SY PLD	--	V X.xxy-yy	
	SY CPU	--	V X.xxy-yy	
	AT PLD	--	V X.xxy-yy	
	AT CPU	--	V X.xxy-yy	
	Update	--	Execute by Enter.	Updates the system. Consult your local Sony representative if you need to update the system.
<Maintenance> Maintenance tasks	APR (Auto Pixel Restoration)	--	Execute by Enter.	Automatically adjusts the image sensor.
	VF Delay (Clock)	1	0, 1, 2, 3, 4	Sets the delay of the viewfinder and HD-Y signals relative to the SDI signal.

Appendix

Metadata

The camera and lens metadata is output on the master output, and is recorded on the SR-R4. The output metadata is comprised by metadata in format based on SMPTE RDD18 and non-realtime metadata in proprietary format. Slate information entered using the F65Remote application on a tablet device is output in non-realtime metadata.

The following metadata items are output.

RDD 18 format metadata set

Lens unit metadata set

Item name	Data type	Length (bytes)	Local tag	Meaning
Lens Unit Metadata	Set Key (UL)	16	–	Lens Unit Metadata Set Key. 06.0E.2B.34.02.53.01.01.0C.02.01.01.01.01.00.00
Length	BER Length	4	–	Metadata set length.
Lens Attributes	UTF8 String	Variable	80.07	Lens classification, excluding Cooke /i lens.

Camera unit metadata set

Item name	Data type	Length (bytes)	Local tag	Meaning
Camera Unit Metadata	Set Key (UL)	16	–	Camera Unit Metadata Set Key. 06.0E.2B.34.02.53.01.01.0C.02.01.01.02.01.00.00
Length	BER Length	4	–	Metadata set length.
Exposure Index of Photo Meter	UInt16	2	81.15	Setting of the photo meter in ISO exposure index.
Neutral Density Filter Wheel Setting	UInt16	2	81.03	Transmittance of the built-in optical density (ND) filter.
Capture Frame Rate	Rational	8	81.06	Rate at which frames are captured in frames per second.
Image Sensor Readout Mode	UInt8	1	81.07	Image sensor readout mode.
Shutter Speed (Angle)	UInt32	4	81.08	Shutter speed as an angle (measured in minutes).

Item name	Data type	Length (bytes)	Local tag	Meaning
ISO Sensitivity	UInt16	2	81.0B	Sensitivity to light in ISO exposure index.
White Balance	UInt16	2	81.0E	White Balance value defined by the temperature in Kelvin.
Capture Gamma Equation	Label	16	32.10	Type of gamma curve applied to the main line video.
Gamma for CDL	UInt8	1	81.16	Name of the color space that applies ASC CDL.
ASC CDL V1.2	Array of Float16	28	81.17	ASC Color Decision List (V1.2). Contains ten parameters.
Camera Attributes	UTF8 String	Variable	81.14	Model name and serial number of the camera.

Sony F65 camera metadata set

Item name	Data type	Length (bytes)	Local tag	Meaning
User Defined Acquisition Metadata	Set Key (UL)	16	–	User Defined Acquisition Metadata Set Key. 06.0E.2B.34.02.53.01.01. 0C.02.01.01.7F.01.00.00
Length	BER Length	4	–	Sony F65 camera metadata set length.
UDAM Set Identifier	AUID	16	E0.00	Sony F65 metadata set identifier. 20500000-f0c0-1181-9669-08004678031c
Effective Marker Coverage	Rational	8	E1.01	Shrink ratio of the effective frame to the payload picture frame expressed as pixels along the short edges. For example, the coverage value for 90% area of 4096 × 2160 is expressed as 1944/2160.
Effective Marker Aspect Ratio	Rational	8	E1.02	Aspect ratio of the effective frame. For example, the aspect ratio for 90% area of 4096 × 2160 is expressed as 3686/1944.
Camera Process Discrimination Code	UInt16	2	E1.03	For F65 internal use only (F65RAW mode output only).
Rotary Shutter Mode	Boolean	1	E1.04	Mechanical rotary shutter mode. TRUE: Mechanical rotary shutter is in use. FALSE: Electronic shutter only is in use or shutter is off.
Raw Black Code Value	UInt16	2	E1.05	Code value of reference black level (shielded sensor) (F65RAW mode output only).
Raw Gray Code Value	UInt16	2	E1.06	Code value of light from 18% reflectance chart at suitable exposure (F65RAW mode output only).
Raw White Code Value	UInt16	2	E1.07	Code value of light from 90% reflectance chart at suitable exposure (F65RAW mode output only).
Monitoring Base Curve	AUID	16	E1.0B	16-byte UID indicating the monitoring characteristics. Base curve used in combination with CDL, etc.
Monitoring Descriptions	UTF8 String	12	E1.09	Name of LUT applied to the VF/SDI outputs.

Cooke Protocol Lens metadata set

Item name	Data type	Length (bytes)	Local tag	Meaning
User Defined Acquisition Metadata	Set Key (UL)	16	–	User Defined Acquisition Metadata Key 06.0E.2B.34.02.53.01.01.0C.02.01.01.7F.01.00.00
Length	BER Length	4	–	Cooke Protocol Lens metadata set length.

Item name	Data type	Length (bytes)	Local tag	Meaning
UDAM Set Identifier	AUID	16	E0.00	Cooke Protocol Lens metadata set identifier.
Cooke Protocol Calibration Type	UInt8	1	E2.03	Lens data distance unit. 0: mm 1: 0.1 inch
Cooke Protocol Binary Metadata	Data Stream	Variable	E2.01	Lens position data in binary format defined by Cooke /i protocol.
Cooke Protocol User Metadata	Data Stream	Variable	E2.02	Cooke /i protocol user data.
Lens Attribute	UTF8 String	Variable	80.07	Lens serial number.

Non-realtime metadata

Item name	Data type	Length (bytes)	Local tag	Meaning
Slate1 Unit Metadata	Set Key (UL)	1	–	Local definition key (01) for the first packet.
Length	4-byte length	4	–	Data length of first packet, excluding the Key and Length attributes.
Description	UTF8 String	Variable (128 max.)	01.01	Comment area.
Project	UTF8 String	Variable (24 max.)	01.02	Name of project.
Director Name	UTF8 String	Variable (24 max.)	01.03	Name of director.
Director Of Photography Name	UTF8 String	Variable (24 max.)	01.04	Name of director of photography.
Production	UTF8 String	Variable (24 max.)	01.05	Name of production house.
Slate2 Unit Metadata	Set Key (UL)	1		Local definition key (02) for the second packet.
Length	4-byte length	4		Data length of second packet, excluding the Key and Length attributes.
Reel	UTF8 String	Variable (8 max.)	02.01	Reel number.
Scene	UTF8 String	Variable (8 max.)	02.02	Scene number.
Cut	UTF8 String	Variable (8 max.)	02.03	Cut number.
Take	UTF8 String	Variable (8 max.)	02.04	Take number.
Shot	UTF8 String	Variable (8 max.)	02.05	Shot number.
Camera Index	UTF8 String	Variable (8 max.)	02.06	Index used to identify the camera used for shooting.

Warning/Error Messages

If the battery voltage drops or an error is detected when power is applied or during operation, the corresponding indicator lights up/flashes and a message appears on the subdisplay. The error details are displayed in the self-diagnostics on settings page 3 on the subdisplay and in the viewfinder.

Warnings and error messages occurring on the SR-R4 are also displayed in the self-diagnostics field.

For details about SR-R4 messages, refer to the operation manual of the SR-R4.

A message prompt is also displayed in the viewfinder/monitor to execute the APR function if a defect is detected in the image sensor when the camera powers on or if the APR function is not executed regularly. If prompted, execute Automatic Pixel Noise Reduction on the <Maintenance> page of the Diagnosis menu.

Indicator	Subdisplay	Self diagnostics field indication	Meaning
REC: Flashing red	12 V power supply voltage indicator flashing	12V Battery (Near End)	The voltage of the 12 V power supply has fallen to the Near End value setting.
REC: Flashing red rapidly	12 V power supply voltage indicator flashing rapidly	12V Battery (End)	The voltage of the 12 V power supply has fallen to the End value setting.
REC: Flashing red	24 V power supply voltage indicator flashing	24V Battery (Near End)	The voltage of the 24 V power supply has fallen to the Near End value setting.
REC: Flashing red rapidly	24 V power supply voltage indicator flashing rapidly	24V Battery (End)	The voltage of the 24 V power supply has fallen to the End value setting.
REC: Flashing when synced with SR-R4.	Media remaining indicator flashing	Media Remain (Near End)	The remaining media on the SR-R4 has reduced to the Near End value setting.
REC: Flashing when synced with SR-R4.	Media remaining indicator flashing rapidly	Media Remain (End)	The remaining media on the SR-R4 has reduced to the End value setting.
DIAGNOSIS: Flashing red rapidly	Displays same message as self diagnostics field in a dialog.	Temperature NG! Shutdown Camera	The internal camera temperature has reached its limit. Turn off the camera power supply. <i>Consult your local Sony representative.</i>
DIAGNOSIS: Flashing red rapidly	Fan1 NG!	Fan1 NG!	Fan 1 near the top panel stopped. <i>Consult your local Sony representative.</i>
DIAGNOSIS: Flashing red rapidly	Fan2 NG!	Fan2 NG!	Fan 2 near the top panel stopped. <i>Consult your local Sony representative.</i>
DIAGNOSIS: Flashing red	Sync Error	Sync Error	A sync error occurred. <i>If the error continues, consult your local Sony representative.</i>
DIAGNOSIS: Lit red DOCK: Lit yellow	Optical Level Care	Optical Level Care	The optical level of the Recorder connector has reduced to caution level. Clean the Recorder connector or replace the optical module.
DIAGNOSIS: Lit red DOCK: Lit red	Optical Level NG	Optical Level NG	A light reception error occurred with the Recorder connector. Immediately, clean the Recorder connector or replace the optical module.
DIAGNOSIS: Lit red DOCK: Not lit	Optical Level No Input	Optical Level No Input	No signal is input on the Recorder connector.
DIAGNOSIS: Lit red	CRCC Error occurred	CRCC Error occurred	A Cyclic Redundancy Check Code (CRCC) error occurred with the Recorder connector. Clean the recorder connector. <i>If the error continues, even after cleaning, consult your local Sony representative.</i>

Indicator	Subdisplay	Self diagnostics field indication	Meaning
–	Unsupported device	Unsupported device	Unsupported USB device is connected to the USB connector.
–	Hubs not supported	Hubs not supported	The camera does not support USB hubs.

Precautions

Use and storage

Do not subject the unit to severe shocks

The internal mechanism may be damaged or the body warped.

Do not block the ventilation holes

If the ventilation holes are blocked, not only are the characteristics not guaranteed, but also extreme degradation of the internal parts will likely result, causing defects of the camera.

For the locations of the ventilation holes, see the figures in “1-3 Locations and Functions of Parts” (page 11).

After use

Always turn off the power.

Use and storage locations

Store in a level, ventilated place. Avoid using or storing the unit in the following places:

- Places subject to temperature extremes
- Very damp places
- Places subject to severe vibration
- Near strong magnetic fields
- In direct sunlight or close to heaters for extended periods

To prevent electromagnetic interference from portable communications devices

The use of portable telephones and other communications devices near this unit can result in malfunctions and interference with audio and video signals.

It is recommended that the portable communications devices near this unit be powered off.

Note on laser beams

Laser beams may damage the image sensor device. If you shoot a scene that includes a laser beam, be careful not to let the laser beam be directed into the lens of the camera.

Condensation

If you move the camera from a very cold place to a warm place, or use it in a damp location, condensation may form on the lens or inside the camera.

The camera has no built-in condensation indicator. If you find condensation on the body or lens, switch the camera off and wait for the condensation to disappear for about one hour.

Image sensor phenomena

The following phenomena that may appear in images are specific to image sensors. They do not indicate malfunctions.

White flecks

Although the image sensors are produced with high-precision technologies, fine white flecks may be generated on the screen in rare cases, caused by cosmic rays.

This is related to the principle of image sensors and is not a malfunction.

The white flecks especially tend to be seen

- when operating at a high environmental temperature

Aliasing

When fine patterns, stripes, or lines are shot, they may appear jagged or flicker.

To forcibly open the shutter

Should the shutter to control incoming light to the image sensor not open, immediately consult your local Sony representative.

If you want to continue shooting urgently, you can use the shutter emergency open screw (*page 11*) to forcibly open the shutter to a position that ensures an optical light path.

For information about using the shutter emergency open screw, consult your local Sony representative.

When setting the video format

It is recommended that the power be turned off and back on again after changing the video format.

Cleaning the Recorder Connector

Note

Before cleaning the recorder connector, always check that the power supply is disconnected before proceeding.

If the recorder connector is dirty, there is increased risk of errors in the data transmission between the camera and the SR-R4. The recorder connector should be cleaned if any of the following conditions occurs.

- DOCK indicator is lit yellow or red.
- DIAGNOSIS indicator is lit red and the “CRCC Error occurred” message is displayed.

You will need the following items in order to clean the recorder connector:

- Commercially available optical fiber cleaning swabs
- 99.5% (or higher) pure alcohol

- 1 Remove the SR-R4. If the SR-R4 was not connected, remove the connector cap from the recorder connector.
- 2 Press the recorder connector using your finger ①, and open the protective shutter to expose the optical contacts.

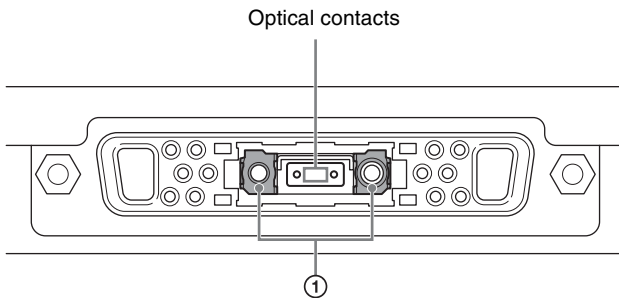

- 3 Dip an optical fiber cleaning swab in alcohol and gently wipe the whole optical contacts area about five times.

Notes

- Always use alcohol only in well-ventilated areas away from heat or flame.
- Wiping firmly may damage the optical fiber contacts.

- 4 Release the connector’s protective shutter, and connect the SR-R4. If not connecting the SR-R4, reattach the connector cap.

About “Memory Stick Duo”

Supported types of “Memory Stick”

You can use “Memory Stick Duo” or “Memory Stick PRO Duo.”

The camera operations have been checked using “Memory Stick” media up to 32 GB.

This camera is not compliant with high-speed data transfer with this type of “Memory Stick.”

Operations checked with:

MSX-M2GN
MSX-M1GST
MSX-M2GST
MS-HX8
MS-HX32
MS-MT2G
MS-MT4G
MS-MT16G
MS-MT32G

Note on data read/write speed

Data read/write speed may vary depending on the combination of the “Memory Stick” and “Memory Stick” compliant product you use.

Inserting a “Memory Stick Duo”

Insert a “Memory Stick Duo” with the label side facing left into the “Memory Stick Duo” slot until it clicks and the access lamp lights in red. Check that the access lamp then goes off.

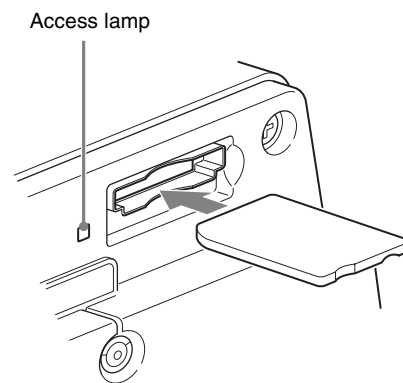

Note

If it does not fit into the slot properly or if there is some resistance when you insert it, the “Memory Stick Duo” may be turned around or upside-down. Do not force the “Memory Stick Duo” into the slot. Confirm the direction of the notch and arrow on the “Memory Stick Duo” before

inserting the “Memory Stick Duo,” and then try inserting it again.

To remove a “Memory Stick Duo”

Confirm that the access lamp is not flashing red, then lightly push in the “Memory Stick Duo” to release the lock.

Note

If the access lamp is flashing red, data is being read from or written to the “Memory Stick Duo.” At this time, do not shake the product or subject it to shock. Do not turn off the power to the product or remove the “Memory Stick Duo.” Doing so may damage the data.

Protecting saved data

To prevent accidental erasure of important setup data, use the LOCK switch on the “Memory Stick Duo.”

Slide the switch upward to the write protect position.

This ensures that you cannot inadvertently overwrite data on the “Memory Stick Duo.”

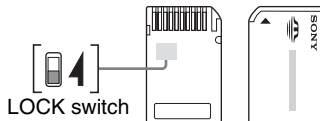

Note

The “Memory Stick Duo” does not have a LOCK switch. When using “Memory Stick Duo” media, be careful not to inadvertently overwrite or erase your data.

Precautions

- Do not attach anything other than the supplied label to the “Memory Stick Duo” labeling position.
- Attach the label so that it does not stick out beyond the labeling position.
- Carry and store the “Memory Stick Duo” in its case.
- Do not touch the connector of the “Memory Stick Duo” with anything, including your finger or metallic objects.
- Do not strike, bend, or drop the “Memory Stick Duo.”
- Do not disassemble or modify the “Memory Stick Duo.”
- Do not allow the “Memory Stick Duo” to get wet.
- Do not use or store the “Memory Stick Duo” in a location that is:
 - Extremely hot, such as in a car parked in the sun
 - Under direct sunlight
 - Very humid or subject to corrosive substances
- To prevent data loss, make backups of data frequently. In no event will Sony be liable for any loss of data.
- Unauthorized recording may be contrary to the provisions of copyright law. When you use a “Memory Stick Duo” that has been pre-recorded, be sure that the material has been recorded in accordance with copyright and other applicable laws.

- “Memory Stick” and  are trademarks of Sony Corporation.
- “Memory Stick Duo” and **MEMORY STICK DUO** are trademarks of Sony Corporation.
- “Memory Stick PRO Duo” and **MEMORY STICK PRO DUO** are trademarks of Sony Corporation.

Specifications

General

Power requirements	10.5 V to 17 V DC
Power consumption	Approx. 65 W with 23.98 PsF (Mechanical rotary shutter operating, not including lens, viewfinder)
Operating temperature	0 °C to 40 °C (32 °F to 104 °F)
Storage temperature	-20 °C to +60 °C (-4 °F to +140 °F)

Imagers

Imagers	Super 35-mm CMOS image sensor
Method	Single sensor
Aspect ratio	17:9

Electrical characteristics

Latitude	14-stop
Registration	Within 0.02% (not including lens distortion)
Geometric distortion	Negligible (not including lens distortion)

Optical system specifications

Lens mount	PL Mount
Flange focal length	52.00 mm (-0.03 mm to +0.05 mm adjustable in 0.01 mm increments by shim replacement)

Input/output connectors

DC IN	LEMO 8-pin male (1), 10.5 V to 17 V DC, 24 V DC
DC OUT	12 V: 11-pin (1), 12 V DC, 4 A maximum 24 V: 3-pin (1), 24 V DC, 4 A maximum (The usable current may be limited depending on the load and input conditions.)
VF	20-pin (1)
LENS	12-pin (1)
SDI OUT	4:2:2, BNC type (2), HD-SDI signal, BTA-S004A-compliant, 75 ohms, 0.8 Vp-p, 1.485 Gbps
HD-Y OUT	BNC type (1), 75 ohms, 1.0 Vp-p

GENLOCK IN	BNC type (1), 75 ohms, SMPTE 274M HD 3-level sync, 0.6 Vp-p Or HD-SDI signal, BTA-S004A- compliant
REMOTE	8-pin (1)
EXT I/O	LEMO 5-pin, female (1)
$\frac{\square}{\square}$ (network)	RJ-45 type (1), 10BASE-T, 100BASE- TX
Lens mount hot shoe	4-pin (2), conforming to ARRI LDS (Lens Data System) and Cooke /i Intelligent Electronic Lens System
USB	Type A, USB2.0 Hi-Speed (2)
“Memory Stick” (MS)/SD memory card	Combo-connector (1) Supports “Memory Stick Duo”, “Memory Stick PRO Duo” Supports SD memory cards, SDHC memory cards up to class 10

Supplied accessories

+B3 × 5 screws (4)
Cable clamp belt (1)
Belt bracket (1)
Power cable connector (LEMO 8-pin) (1)
Filter mounting kit (holder, mounting tool, filter template) (1)
Operation guide (1)
Operation manual (CD-ROM) (1)

Optional accessories

Portable Memory Recorder SR-R4
HD Electronic Viewfinder HDVF-C30WR (2.7-inch type, color)
Wi-Fi Adapter CBK-WA01 “Memory Stick Duo”

Design and specifications are subject to change without notice.

Note

Always verify that the unit is operating properly before use. SONY WILL NOT BE LIABLE FOR DAMAGES OF ANY KIND INCLUDING, BUT NOT LIMITED TO, COMPENSATION OR REIMBURSEMENT ON ACCOUNT OF THE LOSS OF PRESENT OR PROSPECTIVE PROFITS DUE TO FAILURE OF THIS UNIT, EITHER DURING THE WARRANTY PERIOD OR AFTER EXPIRATION OF THE WARRANTY, OR FOR ANY OTHER REASON WHATSOEVER.

Dimensions

Unit: mm (inches)

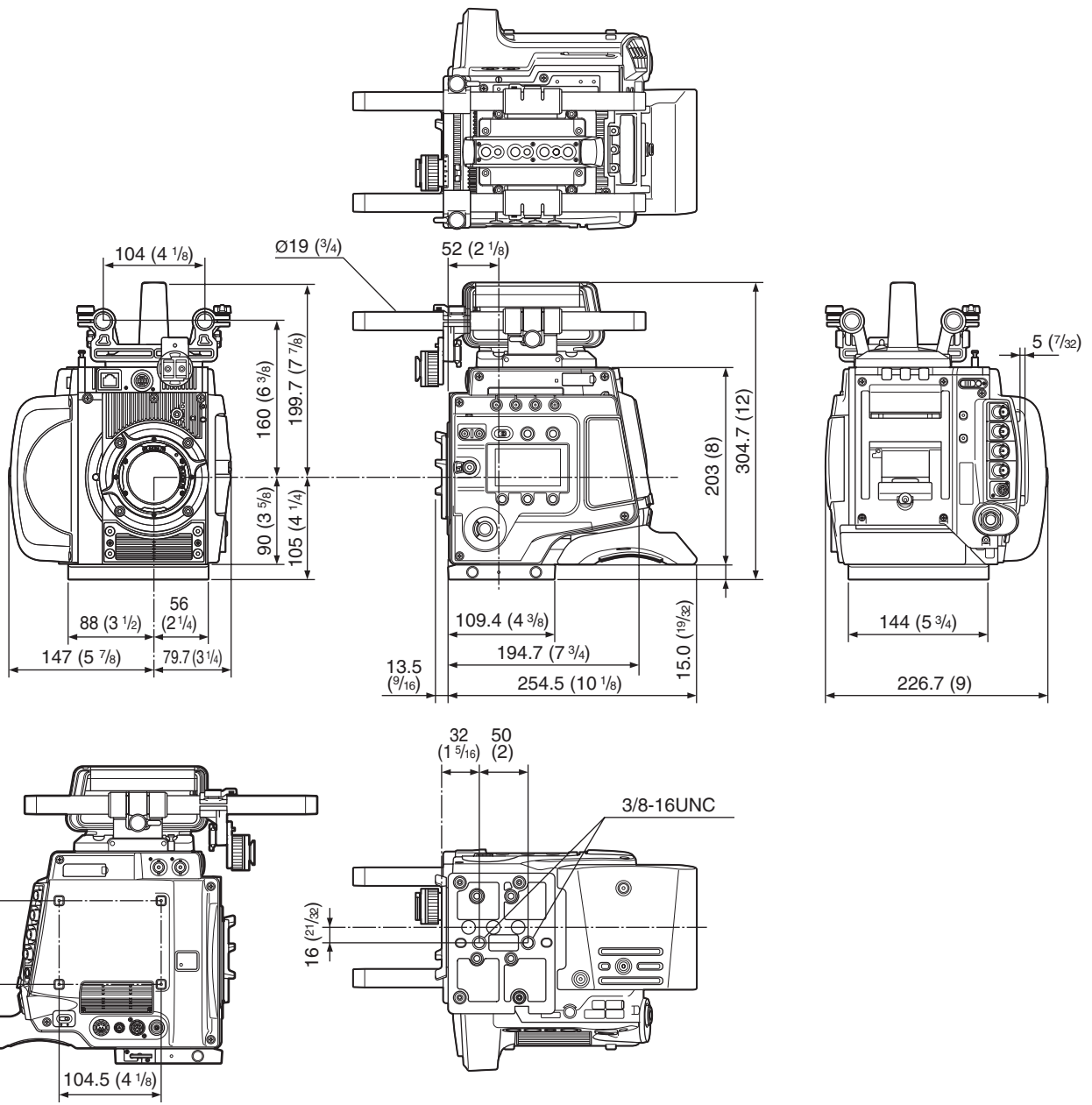

Weight: Camera head 5 kg (11 lb)
 With accessories 6.5 kg (14 lb 5 oz)

Connector Pin Assignments

REMOTE (8-pin female)

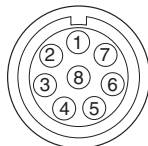

(External View)

No.	Signal	I/O	Specifications
1	TX (+)	OUT	SERIAL Data out
2	TX (-)	OUT	
3	RX (+)	IN	SERIAL Data in
4	RX (-)	IN	
5	TX-GND	—	GND for TX
6	UNREG	OUT	+10.5 to +17 V dc, 200mA (max)
7	UNREG-GND	—	GND for UNREG
8	VIDEO	OUT	75Ω, 1.0 Vp-p
	CHASSIS GND	—	CHASSIS GND

Lens-mount hot shoe (4-pin)

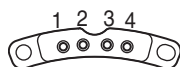

No.	Signal	I/O	Specifications
1	RX	IN	SERIAL DATA in
2	TX	OUT	SERIAL DATA out
3	GND	—	GND for +24 V
4	+24 V	OUT	+24 V, 200 mA (MAX)

LENS (12-pin female)

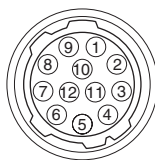

(External View)

No.	Signal	I/O	Specifications
1	RET VIDEO ENABLE	IN	Not used
2	VTR START/ STOP	IN	Not used
3	GND	—	GND for UNREG
4	—	—	Not used

No.	Signal	I/O	Specifications
5	IRIS CONT	OUT	+3.4 V (F16) to +6.2 V (F2.8)
6	UNREG	OUT	+10.5 V to +17 V 500 mA (MAX)
7	IRIS POSITION	IN	+3.4 V (F16) to +6.2 V (F2.8)
8	—	—	Not used
9	—	—	Not used
10	—	—	Not used
11	NC		No connection
12	NC		No connection

VF (20-pin female)

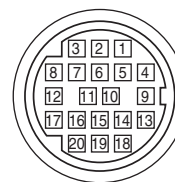

(External View)

No.	Signal	I/O	Specifications
1	S-DATA	IN/OUT	TTL level
2	NC		No connection
3	NC		No connection
4	SCK	OUT	TTL level
5	NC		No connection
6	NC		No connection
7	NC		No connection
8	G TALLY	OUT	ON: 5 V OFF: GND
9	NC		No connection
10	NC		No connection
11	NC		No connection
12	Y VIDEO	OUT	1.0 Vp-p, Zo=75Ω
13	VIDEO GND	—	GND for VIDEO
14	Pb VIDEO	OUT	±0.35 Vp-p, Zo=75Ω
15	Pr VIDEO	OUT	±0.35 Vp-p, Zo=75Ω
16	NC		No connection
17	R TALLY	OUT	ON: 5 V OFF: GND
18	NC		No connection
19	UNREG GND	—	GND for UNREG
20	UNREG	OUT	+10.5 V to +17 V

DC IN (8-pin male)

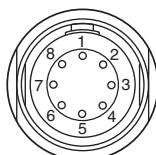

(External View)

No.	Signal	I/O	Specifications
1	UNREG_GND	—	GND for +12 V
2	UNREG_GND	—	GND for +12 V
3	UNREG_GND (24 V)	—	GND for +24 V
4	UNREG_24 V_IN	IN	+24 V
5	UNREG_12 V_IN	IN	+12 V
6	UNREG_12 V_IN	IN	+12 V
7	UNREG_12 V_IN	IN	+12 V
8	UNREG_GND	—	GND for +12 V

EXT I/O (5-pin female)

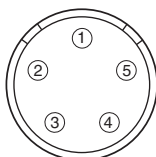

(External View)

No.	Signal	I/O	Specifications
1	EXT_CMD1_OUT	OUT	RS-232C
2	EXT_CMD0_OUT	OUT	
3	EXT_CMD1_IN	IN	
4	EXT_CMD0_IN	IN	
5	GND	—	

□ (Modular jack)

Conforming to IEEE 802.3u (100BASE-TX), IEEE802.3 (10BASE-T)

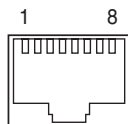

(External View)

No.	Signal	I/O	Specifications
1	TXD (+)	OUT	
2	TXD (-)	OUT	
3	RXD (+)	IN	
4	NC	—	
5	NC	—	
6	RXD (-)	IN	

No.	Signal	I/O	Specifications
7	NC	—	
8	NC	—	

USB

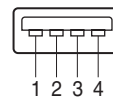

(External View)

No.	Signal	I/O	Specifications
1	VBUS	OUT	5 V dc, 500 mA (max)
2	D-	IN/OUT	
3	D+	IN/OUT	
4	GND	—	

DC OUT 12 V (11-pin female)

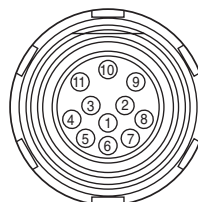

(External View)

No.	Signal	I/O	Specifications
1	NC		
2	NC		
3	NC		
4	NC		
5	NC		
6	NC		
7	NC		
8	NC		
9	UNREG_GND	—	
10	NC		
11	UNREG_12 V_OUT	OUT	+12 V DC 4 A (MAX)

DC OUT 24 V (3-pin female)

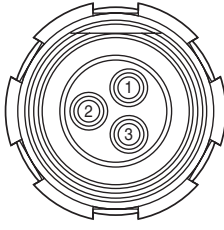

(External View)

No.	Signal	I/O	Specifications
1	UNREG_GND (24 V)	—	
2	UNREG_24 V_OUT	OUT	+24 V DC 4 A (MAX)
3	REC trigger	IN	OPEN or +5 V: Normal GND: Active

Menu Operation using a Web Browser

The settings menus of this camera can be controlled from a computer using a Web browser.

Supported OS

Windows XP, Windows Vista, Windows 7
Mac OS X

Supported browsers

Firefox 8 or Later
Google Chrome 13 or Later
Safari 5 or later

To display the menu

- 1 Set the IP address in the IP Address field on the <LAN Setting> page in the Network menu.
Example: 192.168.1.2
- 2 Connect a computer to the camera via a hub or directly using a cross cable.
- 3 Launch the web browser on the computer and enter `http://` then the IP address you set on the <LAN Setting> page.

Example: `http://192.168.1.2`

The following menu screen appears.

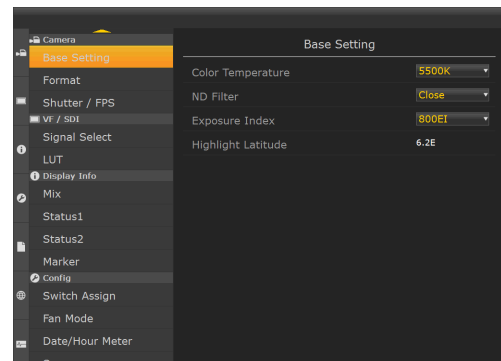

- Windows and Windows Vista are registered trademarks of Microsoft Corporation in the United States and other countries.
- Mac OS is a registered trademark of Apple Inc.
- Firefox is a registered trademark of the Mozilla Foundation in the United States and other countries.
- Google Chrome is a trademark of Google Inc.

Operation using a Tablet Device

The camera can be operated wirelessly by installing the “F65Remote” application for tablet devices. A CBK-WA01 Wi-Fi adapter (option) is required for wireless operation.

For details about mounting the CBK-WA01, see “2-6 Mounting the CBK-WA01” (page 21).

Operations using F65Remote

- Display and set frequently used menu settings in a list (Control screen)
- Display menu setting status from video signal input to output (Output Signal Map screen)
- Display and change camera configuration settings (Menu screen)*
- Display Operation Manual (Manual screen)
- Display list of files recorded in SRMemory (File List screen)**
- Display slate information (Slate screen)**

* Some menus cannot be displayed.

** Not supported in Android version.

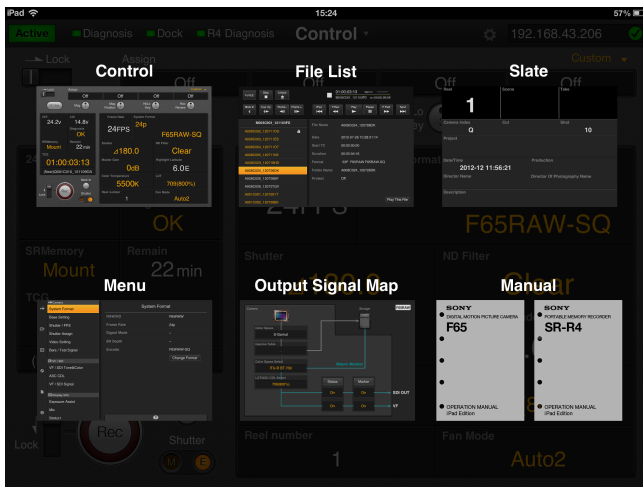

Supported devices

iPad, iPad2, iPad (third generation)¹⁾ iOS 5.0 or later
Android devices²⁾ Android 3.2

1) Use of iPad2 or iPad (third generation) or later is recommended.

2) Operation tested on Sony tablet S devices only.

Camera and Tablet Device Connections

There are two modes supported for connecting devices.

Infrastructure mode

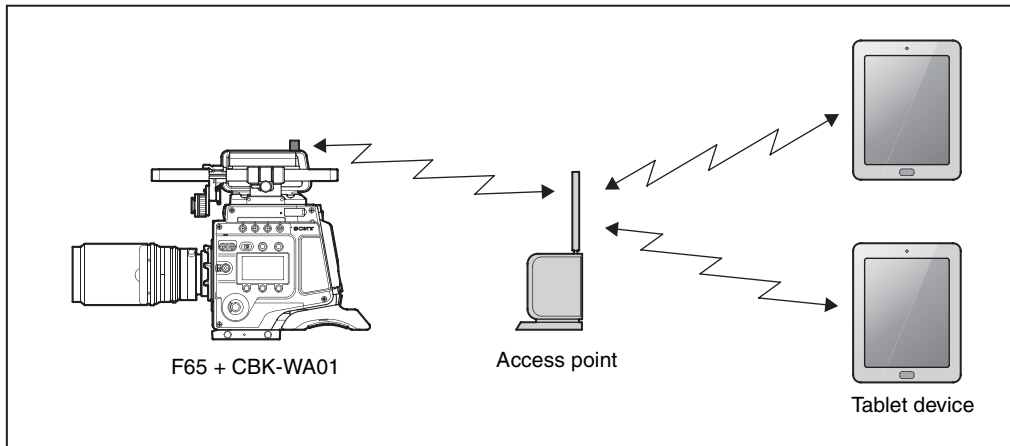

Ad-hoc mode

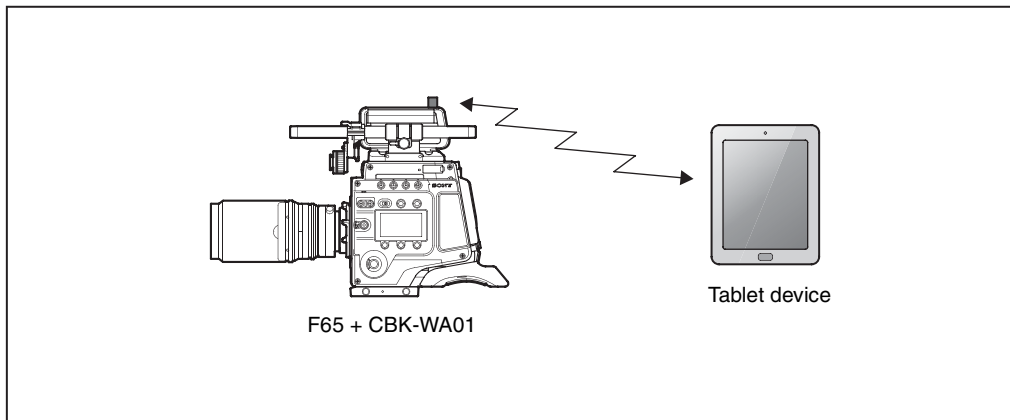

Infrastructure mode

Uses a Wi-Fi connection between the camera and tablet device via a wireless LAN access point.

In this mode, multiple devices can communicate with the camera wirelessly via the access point. Use this mode if you plan to connect with and control a camera from more than one tablet device.

Ad-hoc mode

Uses a direct Wi-Fi connection between the camera and tablet device.

In this mode, an access point is not required, and only a single device can communicate with the camera wirelessly. Use this mode if an access point cannot be set up due to difficulty guaranteeing the power supply or other reasons.

For details about the connection method, refer to the help for the tablet device.

Notes

- Connection using IEEE802.11n is not supported in ad-hoc mode. Data encryption method uses WEP only.

- Some tablet devices are not equipped with the necessary hardware for ad-hoc mode. For details, refer to the operating instructions for your tablet device.
- While multiple tablet devices can connect to the camera in infrastructure mode, only the device that is “Active” may modify the camera settings. Other connected devices may only monitor the settings.
- If the camera is connected using a network cable and the IP address settings on the <LAN Setting> page and the <Wi-Fi Setting> page in the Network menu are the same, then Wi-Fi is disabled. To use LAN and Wi-Fi simultaneously, set different values for the IP address settings on the <LAN Setting> page and the <Wi-Fi Setting> page. If the camera is not connected using a network cable, then Wi-Fi is enabled, even if the same IP address is set on both pages.
- If connection is difficult or unstable when using WEP as the data encryption method, use another encryption method or another device.

iPad is a trademark of Apple Inc., registered in the U.S. and other countries. IOS is a trademark or registered trademark of Cisco in the U.S. and other countries and is used under license. Android is a trademark of Google Inc.

Color Space According to the COLOR SPACE Settings

The color space of the camera main signal, recorded by the SR-R4 when connected, is S-GAMUT mode. The color space of the output signal for the viewfinder and SDI OUT connectors is converted to ITU-R BT.709 color space.

Colorimetry

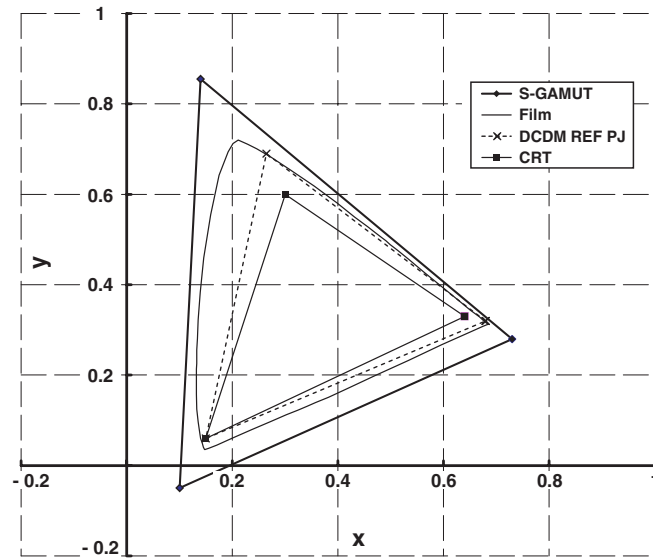

1. Virtual chromaticity points at S-GAMUT

The virtual color space at S-GAMUT is shown in the above chart. The virtual chromaticity points are as follows:

	x	y
R	0.73	0.28
G	0.14	0.855
B	0.1	-0.05

When converting the color space of a video source shot with this camera in S-GAMUT mode, use these virtual chromaticity points.

These chromaticity points are “virtual” because they do not represent the actual, accurate color space but are the calculated values for calculation of color space conversion. These virtual chromaticity points have been introduced because the actual color space cannot be represented as a triangle in this colorimetry.

The following equation provides a simple conversion from the color space for S-GAMUT to that for conventional cameras (HDC-F950, HDW-F900R, etc.):

$$\begin{bmatrix} R \\ G \\ B \end{bmatrix} = \begin{bmatrix} 1.306240 & -0.233075 & -0.073165 \\ -0.126851 & 1.178376 & -0.051526 \\ 0.000120 & -0.085649 & 1.085529 \end{bmatrix} \begin{bmatrix} R_w \\ G_w \\ B_w \end{bmatrix}$$

(R_w, G_w, B_w): RGB values for the original color space for S-GAMUT
(R, G, B): Values after being converted to the color space for conventional cameras

Use the following equations to convert from S-GAMUT to another color gamut.

Converting to ITU-R.BT709/sRGB

$$\begin{bmatrix} R \\ G \\ B \end{bmatrix} = \begin{bmatrix} 1.8779151284 & -0.7941687613 & -0.0837463671 \\ -0.1768069813 & 1.3509996209 & -0.1741926396 \\ -0.0262011264 & -0.1484222623 & 1.1746233888 \end{bmatrix} \begin{bmatrix} R_w \\ G_w \\ B_w \end{bmatrix}$$

(R_w, G_w, B_w): RGB values for the original color space for S-GAMUT
(R, G, B): RGB values after conversion

Converting to ACES-GAMUT (Academy Color Encoding Specification)

• Daylight: 5500K

$$\begin{bmatrix} R \\ G \\ B \end{bmatrix} = \begin{bmatrix} 0.8764457030 & 0.0145411681 & 0.1090131290 \\ 0.0774075345 & 0.9529571767 & -0.0303647111 \\ 0.0573564351 & -0.1151066335 & 1.0577501984 \end{bmatrix} \begin{bmatrix} R_w \\ G_w \\ B_w \end{bmatrix}$$

• Tungsten: 3200K or 4300K

$$\begin{bmatrix} R \\ G \\ B \end{bmatrix} = \begin{bmatrix} 1.0110238740 & -0.1362526051 & 0.1252287310 \\ 0.1011994504 & 0.9562196265 & -0.0574190769 \\ 0.0600766530 & -0.1010185315 & 1.0409418785 \end{bmatrix} \begin{bmatrix} R_w \\ G_w \\ B_w \end{bmatrix}$$

(R_w, G_w, B_w): RGB values for the original color space for S-GAMUT
(R, G, B): RGB values after conversion

Use the following equation to express the S-GAMUT as an XYZ color space.

$$\begin{bmatrix} X \\ Y \\ Z \end{bmatrix} = \begin{bmatrix} 0.7064827132 & 0.1288010498 & 0.1151721641 \\ 0.2709796708 & 0.7866064112 & -0.0575860820 \\ -0.0096778454 & 0.0046000375 & 1.0941355587 \end{bmatrix} \begin{bmatrix} R_w \\ G_w \\ B_w \end{bmatrix}$$

(R_w, G_w, B_w): RGB values for the original color space for S-GAMUT
(X, Y, Z): Values after conversion to XYZ color space

2. Color space for film

The color space for film shown in the above chart represents measurements from VISION Premier Film EK 2393.

Notice Concerning Software Governed by the GNU GPL/LGPL

This product includes software to which the GNU General Public License (“GPL”) or GNU Lesser General Public License (“LGPL”) applies.

Under the terms of the GPL/LGPL, of which a copy is attached, you have the right to obtain, modify, and distribute copies of the source code of this software.

Package list

lzo
blktrace
compcache
directfb
e2fsprogs
net-tools
gawk
gdisk
gpm
iputils
libtool
libcap
memstat
mkcramfs
ncurses
nfs-utils
procinfo
pump
time
util-linux-ng
vsftpd
wireless-tools
acl
bash
busybox
coreutils
diffutils
dosfstools
ethtool
findutils
fuse
glib
grep
ksymoos
less
liboil
libusb
minicom
oprofile
procps
setserial
tar
tofrodos

vim
which
xz
iptables
mtd-utils
glibc-libpthread_ptt
module-init-tools
netbase
lrzsz
mdadm
linux-kernel
at
camif
logrotate
sysklogd
udhcp

To obtain information on the source code and/or the source code for this software. Consult your nearest Sony Service.

The GNU General Public License (GPL)

Version 2, June 1991

Copyright (C) 1989, 1991 Free Software Foundation, Inc.
59 Temple Place, Suite 330, Boston, MA 02111-1307 USA
Everyone is permitted to copy and distribute verbatim copies
of this license document, but changing it is not allowed.

Preamble

The licenses for most software are designed to take away your freedom to share and change it. By contrast, the GNU General Public License is intended to guarantee your freedom to share and change free software—to make sure the software is free for all its users. This General Public License applies to most of the Free Software Foundation’s software and to any other program whose authors commit to using it. (Some other Free Software Foundation software is covered by the GNU Library General Public License instead.) You can apply it to your programs, too.

When we speak of free software, we are referring to freedom, not price. Our General Public Licenses are designed to make sure that you have the freedom to distribute copies of free software (and charge for this service if you wish), that you receive source code or can get it if you want it, that you can change the software or use pieces of it in new free programs; and that you know you can do these things.

To protect your rights, we need to make restrictions that forbid anyone to deny you these rights or to ask you to surrender the rights. These restrictions translate to certain responsibilities for you if you distribute copies of the software, or if you modify it.

For example, if you distribute copies of such a program, whether gratis or for a fee, you must give the recipients all the rights that you have. You must make sure that they, too, receive or can get the source code. And you must show them these terms so they know their rights.

We protect your rights with two steps: (1) copyright the software, and (2) offer you this license which gives you legal permission to copy, distribute and/or modify the software.

Also, for each author’s protection and ours, we want to make certain that everyone understands that there is no warranty for this free software. If the software is modified by someone else and passed on, we want its recipients to know that what they have is not the original, so that any problems introduced by others will not reflect on the original authors’ reputations.

Finally, any free program is threatened constantly by software patents. We wish to avoid the danger that redistributors of a free program will individually obtain patent licenses, in effect making the program proprietary. To prevent this, we have made it clear that any patent must be licensed for everyone’s free use or not licensed at all.

The precise terms and conditions for copying, distribution and modification follow.

TERMS AND CONDITIONS FOR COPYING, DISTRIBUTION AND MODIFICATION

0. This License applies to any program or other work which contains a notice placed by the copyright holder saying it may be distributed under the terms of this General Public License. The “Program”, below, refers to any such program or work, and a “work based on the Program” means either the Program or any derivative work under copyright law: that is to say, a work containing the Program or a portion of it, either verbatim or with modifications and/or translated into another language. (Hereinafter, translation is included without limitation in the term “modification”.) Each licensee is addressed as “you”.

Activities other than copying, distribution and modification are not covered by this License; they are outside its scope. The act of running the Program is not restricted, and the output from the Program is covered only if its contents constitute a work based on the Program (independent of having been made by running the Program). Whether that is true depends on what the Program does.

1. You may copy and distribute verbatim copies of the Program’s source code as you receive it, in any medium, provided that you conspicuously and appropriately publish on each copy an appropriate copyright notice and disclaimer of warranty; keep intact all the notices that refer to this License and to the absence of any warranty; and give any other recipients of the Program a copy of this License along with the Program.

You may charge a fee for the physical act of transferring a copy, and you may at your option offer warranty protection in exchange for a fee.

2. You may modify your copy or copies of the Program or any portion of it, thus forming a work based on the Program, and copy and distribute such modifications or work under the terms of Section 1 above, provided that you also meet all of these conditions:
 - a) You must cause the modified files to carry prominent notices stating that you changed the files and the date of any change.
 - b) You must cause any work that you distribute or publish, that in whole or in part contains or is derived from the Program or any part thereof, to be licensed as a whole at no charge to all third parties under the terms of this License.
 - c) If the modified program normally reads commands interactively when run, you must cause it, when started running for such interactive use in the most ordinary way, to print or display an announcement including an appropriate copyright notice and a notice that there is no warranty (or else, saying that you provide a warranty) and that users may redistribute the program under these conditions, and telling the user how to view a copy of this License. (Exception: if the Program itself is interactive but does not normally print such an announcement, your work based on the Program is not required to print an announcement.)

These requirements apply to the modified work as a whole. If identifiable sections of that work are not derived from the Program, and can be reasonably considered independent and separate works in themselves, then this License, and its terms, do not apply to those sections when you distribute them as separate works. But when you distribute the same sections as part of a whole which is a work based on the Program, the distribution of the whole must be on the terms of this License, whose permissions for other licensees extend to the entire whole, and thus to each and every part regardless of who wrote it.

Thus, it is not the intent of this section to claim rights or contest your rights to work written entirely by you; rather, the intent is to exercise the right to control the distribution of derivative or collective works based on the Program.

In addition, mere aggregation of another work not based on the Program with the Program (or with a work based on the Program) on a volume of a storage or distribution medium does not bring the other work under the scope of this License.

3. You may copy and distribute the Program (or a work based on it, under Section 2) in object code or executable form under the terms of Sections 1 and 2 above provided that you also do one of the following:
 - a) Accompany it with the complete corresponding machine-readable source code, which must be distributed under the terms of Sections 1 and 2 above on a medium customarily used for software interchange; or,
 - b) Accompany it with a written offer, valid for at least three years, to give any third party, for a charge no more than your cost of physically performing source distribution, a complete machine-readable copy of the corresponding source code, to be distributed under the terms of Sections 1 and 2 above on a medium customarily used for software interchange; or,
 - c) Accompany it with the information you received as to the offer to distribute corresponding source code. (This alternative is allowed only for noncommercial distribution and only if you received the program in object code or executable form with such an offer, in accord with Subsection b above.)

The source code for a work means the preferred form of the work for making modifications to it. For an executable work, complete source code means all the source code for all modules it contains, plus any associated interface definition files, plus the scripts used to control compilation and installation of the executable. However, as a special exception, the source code distributed need not include anything that is normally distributed (in either source or binary form) with the major components (compiler, kernel, and so on) of the operating system on which the executable runs, unless that component itself accompanies the executable.

If distribution of executable or object code is made by offering access to copy from a designated place, then offering equivalent access to copy the source code from the same place counts as distribution of the source code, even though third parties are not compelled to copy the source along with the object code.

4. You may not copy, modify, sublicense, or distribute the Program except as expressly provided under this License. Any attempt otherwise to copy, modify, sublicense or distribute the Program is void, and will automatically terminate your rights under this License. However, parties who have received copies, or rights, from you under this License will not have their licenses terminated so long as such parties remain in full compliance.
5. You are not required to accept this License, since you have not signed it. However, nothing else grants you permission to modify or distribute the Program or its derivative works. These actions are prohibited by law if you do not accept this License. Therefore, by modifying or distributing the Program (or any work based on the Program), you indicate your acceptance of this License to do so, and all its terms and conditions for copying, distributing or modifying the Program or works based on it.
6. Each time you redistribute the Program (or any work based on the Program), the recipient automatically receives a license from the original licensor to copy, distribute or modify the Program subject to these terms and conditions. You may not impose any further restrictions on the recipients' exercise of the rights granted herein. You are not responsible for enforcing compliance by third parties to this License.
7. If, as a consequence of a court judgment or allegation of patent infringement or for any other reason (not limited to patent issues), conditions are imposed on you (whether by court order, agreement or otherwise) that contradict the conditions of this License, they do not excuse you from the conditions of this License. If you cannot distribute so as to satisfy simultaneously your obligations under this License and any other pertinent obligations, then as a consequence you may not distribute the Program at all. For example, if a patent license would not permit royalty-free redistribution of the Program by all those who receive copies directly or indirectly through you, then the only way you could satisfy both it and this License would be to refrain entirely from distribution of the Program.

If any portion of this section is held invalid or unenforceable under any particular circumstance, the balance of the section is intended to apply and the section as a whole is intended to apply in other circumstances.

It is not the purpose of this section to induce you to infringe any patents or other property right claims or to contest validity of any such claims; this section has the sole purpose of protecting the integrity of the free software distribution system, which is implemented by public license practices. Many people have made generous contributions to the wide range of software distributed through that system in reliance on consistent application of that system; it is up to the

author/donor to decide if he or she is willing to distribute software through any other system and a licensee cannot impose that choice.

This section is intended to make thoroughly clear what is believed to be a consequence of the rest of this License.

8. If the distribution and/or use of the Program is restricted in certain countries either by patents or by copyrighted interfaces, the original copyright holder who places the Program under this License may add an explicit geographical distribution limitation excluding those countries, so that distribution is permitted only in or among countries not thus excluded. In such case, this License incorporates the limitation as if written in the body of this License.
9. The Free Software Foundation may publish revised and/or new versions of the General Public License from time to time. Such new versions will be similar in spirit to the present version, but may differ in detail to address new problems or concerns.

Each version is given a distinguishing version number. If the Program specifies a version number of this License which applies to it and “any later version”, you have the option of following the terms and conditions either of that version or of any later version published by the Free Software Foundation. If the Program does not specify a version number of this License, you may choose any version ever published by the Free Software Foundation.

10. If you wish to incorporate parts of the Program into other free programs whose distribution conditions are different, write to the author to ask for permission. For software which is copyrighted by the Free Software Foundation, write to the Free Software Foundation; we sometimes make exceptions for this. Our decision will be guided by the two goals of preserving the free status of all derivatives of our free software and of promoting the sharing and reuse of software generally.

NO WARRANTY

11. BECAUSE THE PROGRAM IS LICENSED FREE OF CHARGE, THERE IS NO WARRANTY FOR THE PROGRAM, TO THE EXTENT PERMITTED BY APPLICABLE LAW. EXCEPT WHEN OTHERWISE STATED IN WRITING THE COPYRIGHT HOLDERS AND/OR OTHER PARTIES PROVIDE THE PROGRAM “AS IS” WITHOUT WARRANTY OF ANY KIND, EITHER EXPRESSED OR IMPLIED, INCLUDING, BUT NOT LIMITED TO, THE IMPLIED WARRANTIES OF MERCHANTABILITY AND FITNESS FOR A PARTICULAR PURPOSE. THE ENTIRE RISK AS TO THE QUALITY AND PERFORMANCE OF THE PROGRAM IS WITH YOU. SHOULD THE PROGRAM PROVE DEFECTIVE, YOU ASSUME THE COST OF ALL NECESSARY SERVICING, REPAIR OR CORRECTION.
12. IN NO EVENT UNLESS REQUIRED BY APPLICABLE LAW OR AGREED TO IN WRITING WILL ANY COPYRIGHT HOLDER, OR ANY OTHER PARTY WHO MAY MODIFY AND/OR REDISTRIBUTE THE PROGRAM AS PERMITTED ABOVE, BE LIABLE TO YOU FOR DAMAGES, INCLUDING ANY GENERAL, SPECIAL, INCIDENTAL OR CONSEQUENTIAL DAMAGES ARISING OUT OF THE USE OR INABILITY TO USE THE PROGRAM (INCLUDING BUT NOT LIMITED TO LOSS OF DATA OR DATA BEING RENDERED INACCURATE OR LOSSES SUSTAINED BY YOU OR THIRD PARTIES OR A FAILURE OF THE PROGRAM TO OPERATE WITH ANY OTHER PROGRAMS), EVEN IF SUCH HOLDER OR OTHER PARTY HAS BEEN ADVISED OF THE POSSIBILITY OF SUCH DAMAGES.

END OF TERMS AND CONDITIONS

How to Apply These Terms to Your New Programs

If you develop a new program, and you want it to be of the greatest possible use to the public, the best way to achieve this is to make it free software which everyone can redistribute and change under these terms.

To do so, attach the following notices to the program. It is safest to attach them to the start of each source file to most effectively convey the exclusion of warranty; and each file should have at least the “copyright” line and a pointer to where the full notice is found.

One line to give the program’s name and a brief idea of what it does.
Copyright (C) <year> <name of author>

This program is free software; you can redistribute it and/or modify it under the terms of the GNU General Public License as published by the Free Software Foundation; either version 2 of the License, or (at your option) any later version.

This program is distributed in the hope that it will be useful, but WITHOUT ANY WARRANTY; without even the implied warranty of MERCHANTABILITY or FITNESS FOR A PARTICULAR PURPOSE. See the GNU General Public License for more details.

You should have received a copy of the GNU General Public License along with this program; if not, write to the Free Software Foundation, Inc., 59 Temple Place, Suite 330, Boston, MA 02111-1307 USA

Also add information on how to contact you by electronic and paper mail.

If the program is interactive, make it output a short notice like this when it starts in an interactive mode:

Gnomovision version 69, Copyright (C) year name of author Gnomovision comes with ABSOLUTELY NO WARRANTY; for details type 'show w'. This is free software, and you are welcome to redistribute it under certain conditions; type 'show c' for details.

The hypothetical commands 'show w' and 'show c' should show the appropriate parts of the General Public License. Of course, the commands you use may be called something other than 'show w' and 'show c'; they could even be mouse-clicks or menu items--whatever suits your program.

You should also get your employer (if you work as a programmer) or your school, if any, to sign a "copyright disclaimer" for the program, if necessary. Here is a sample; alter the names:

Yoyodyne, Inc., hereby disclaims all copyright interest in the program 'Gnomovision' (which makes passes at compilers) written by James Hacker.

signature of Ty Coon, 1 April 1989
Ty Coon, President of Vice

This General Public License does not permit incorporating your program into proprietary programs. If your program is a subroutine library, you may consider it more useful to permit linking proprietary applications with the library. If this is what you want to do, use the GNU Library General Public License instead of this License.

GNU Lesser General Public License

Version 2.1, February 1999

Copyright (C) 1991, 1999 Free Software Foundation, Inc.
59 Temple Place, Suite 330, Boston, MA 02111-1307 USA

Everyone is permitted to copy and distribute verbatim copies of this license document, but changing it is not allowed.

[This is the first released version of the Lesser GPL. It also counts as the successor of the GNU Library Public License, version 2, hence the version number 2.1.]

Preamble

The licenses for most software are designed to take away your freedom to share and change it. By contrast, the GNU General Public Licenses are intended to guarantee your freedom to share and change free software--to make sure the software is free for all its users.

This license, the Lesser General Public License, applies to some specially designated software packages--typically libraries--of the Free Software Foundation and other authors who decide to use it. You can use it too, but we suggest you first think carefully about whether this license or the ordinary General Public License is the better strategy to use in any particular case, based on the explanations below.

When we speak of free software, we are referring to freedom of use, not price. Our General Public Licenses are designed to make sure that you have the freedom to distribute copies of free software (and charge for this service if you wish); that you receive source code or can get it if you want it; that you can change the software and use pieces of it in new free programs; and that you are informed that you can do these things.

To protect your rights, we need to make restrictions that forbid distributors to deny you these rights or to ask you to surrender these rights. These restrictions translate to certain responsibilities for you if you distribute copies of the library or if you modify it.

For example, if you distribute copies of the library, whether gratis or for a fee, you must give the recipients all the rights that we gave you. You must make sure that they, too, receive or can get the source code. If you link other code with the library, you must provide complete object files to the recipients, so that they can relink them with the library after making changes to the library and recompiling it. And you must show them these terms so they know their rights.

We protect your rights with a two-step method: (1) we copyright the library, and (2) we offer you this license, which gives you legal permission to copy, distribute and/or modify the library.

To protect each distributor, we want to make it very clear that there is no warranty for the free library. Also, if the library is modified by someone else and passed on, the recipients should know that what they have is not the original version, so that the original author's reputation will not be affected by problems that might be introduced by others.

Finally, software patents pose a constant threat to the existence of any free program. We wish to make sure that a company cannot effectively restrict the users of a free program by obtaining a restrictive license from a patent holder. Therefore, we insist that any patent license obtained for a version of the library must be consistent with the full freedom of use specified in this license.

Most GNU software, including some libraries, is covered by the ordinary GNU General Public License. This license, the GNU Lesser General Public License, applies to certain designated libraries, and is quite different from the ordinary General Public License. We use this license for certain libraries in order to permit linking those libraries into non-free programs.

When a program is linked with a library, whether statically or using a shared library, the combination of the two is legally speaking a combined work, a derivative of the original library. The ordinary General Public License therefore permits such linking only if the entire combination fits its criteria of freedom. The Lesser General Public License permits more lax criteria for linking other code with the library.

We call this license the “Lesser” General Public License because it does Less to protect the user's freedom than the ordinary General Public License. It also provides other free software developers Less of an advantage over competing non-free programs. These disadvantages are the reason we use the ordinary General Public License for many libraries. However, the Lesser license provides advantages in certain special circumstances.

For example, on rare occasions, there may be a special need to encourage the widest possible use of a certain library, so that it becomes a defacto standard. To achieve this, non-free programs must be allowed to use the library. A more frequent case is that a free library does the same job as widely used non-free libraries. In this case, there is little to gain by limiting the free library to free software only, so we use the Lesser General Public License.

In other cases, permission to use a particular library in non-free programs enables a greater number of people to use a large body of free software. For example, permission to use the GNU C Library in non-free programs enables many more people to use the whole GNU operating system, as well as its variant, the GNU/Linux operating system.

Although the Lesser General Public License is Less protective of the users' freedom, it does ensure that the user of a program that is linked with the Library has the freedom and the wherewithal to run that program using a modified version of the Library.

The precise terms and conditions for copying, distribution and modification follow. Pay close attention to the difference between a “work based on the library” and a “work that uses the library”. The former contains code derived from the library, whereas the latter must be combined with the library in order to run.

TERMS AND CONDITIONS FOR COPYING, DISTRIBUTION AND MODIFICATION

0. This License Agreement applies to any software library or other program which contains a notice placed by the copyright holder or other authorized party saying it may be distributed under the terms of this Lesser General Public License (also called “this License”). Each licensee is addressed as “you”.

A “library” means a collection of software functions and/or data prepared so as to be conveniently linked with application programs (which use some of those functions and data) to form executables.

The “Library”, below, refers to any such software library or work which has been distributed under these terms. A “work based on the Library” means either the Library or any derivative work under copyright law: that is to say, a work containing the Library or a portion of it, either verbatim or with modifications and/or translated straightforwardly into another language. (Hereinafter, translation is included without limitation in the term “modification”.)

“Source code” for a work means the preferred form of the work for making modifications to it. For a library, complete source code means all the source code for all modules it contains, plus any associated interface definition files, plus the scripts used to control compilation and installation of the library.

Activities other than copying, distribution and modification are not covered by this License; they are outside its scope. The act of running a program using the Library is not restricted, and output from such a program is covered only if its contents constitute a work based on the Library (independent of the use of the Library in a tool for writing it). Whether that is true depends on what the Library does and what the program that uses the Library does.

1. You may copy and distribute verbatim copies of the Library’s complete source code as you receive it, in any medium, provided that you conspicuously and appropriately publish on each copy an appropriate copyright notice and disclaimer of warranty; keep intact all the notices that refer to this License and to the absence of any warranty; and distribute a copy of this License along with the Library.

You may charge a fee for the physical act of transferring a copy, and you may at your option offer warranty protection in exchange for a fee.

2. You may modify your copy or copies of the Library or any portion of it, thus forming a work based on the Library, and copy and distribute such modifications or work under the terms of Section 1 above, provided that you also meet all of these conditions:
 - a) The modified work must itself be a software library.
 - b) You must cause the files modified to carry prominent notices stating that you changed the files and the date of any change.
 - c) You must cause the whole of the work to be licensed at no charge to all third parties under the terms of this License.
 - d) If a facility in the modified Library refers to a function or a table of data to be supplied by an application program that uses the facility, other than as an argument passed when the facility is invoked, then you must make a good faith effort to ensure that, in the event an application does not supply such function or table, the facility still operates, and performs whatever part of its purpose remains meaningful.

(For example, a function in a library to compute square roots has a purpose that is entirely well-defined independent of the application. Therefore, Subsection 2d requires that any application-supplied function or table used by this function must be optional: if the application does not supply it, the square root function must still compute square roots.)

These requirements apply to the modified work as a whole. If identifiable sections of that work are not derived from the Library, and can be reasonably considered independent and separate works in themselves, then this License, and its terms, do not apply to those sections when you distribute them as separate works. But when you distribute the same sections as part of a whole which is a work based on the Library, the distribution of the whole must be on the terms of this License, whose permissions for other licensees extend to the entire whole, and thus to each and every part regardless of who wrote it.

Thus, it is not the intent of this section to claim rights or contest your rights to work written entirely by you; rather, the intent is to exercise the right to control the distribution of derivative or collective works based on the Library.

In addition, mere aggregation of another work not based on the Library with the Library (or with a work based on the Library) on a volume of a storage or distribution medium does not bring the other work under the scope of this License.

3. You may opt to apply the terms of the ordinary GNU General Public License instead of this License to a given copy of the Library. To do this, you must alter all the notices that refer to this License, so that they refer to the ordinary GNU General Public License, version 2, instead of to this License. (If a newer version than version 2 of the ordinary GNU General Public License has appeared, then you can specify that version instead if you wish.) Do not make any other change in these notices.

Once this change is made in a given copy, it is irreversible for that copy, so the ordinary GNU General Public License applies to all subsequent copies and derivative works made from that copy.

This option is useful when you wish to copy part of the code of the Library into a program that is not a library.

4. You may copy and distribute the Library (or a portion or derivative of it, under Section 2) in object code or executable form under the terms of Sections 1 and 2 above provided that you accompany it with the complete corresponding machine-readable source code, which must be distributed under the terms of Sections 1 and 2 above on a medium customarily used for software interchange.

If distribution of object code is made by offering access to copy from a designated place, then offering equivalent access to copy the source code from the same place satisfies the requirement to distribute the source code, even though third parties are not compelled to copy the source along with the object code.

5. A program that contains no derivative of any portion of the Library, but is designed to work with the Library by being compiled or linked with it, is called a “work that uses the Library”. Such a work, in isolation, is not a derivative work of the Library, and therefore falls outside the scope of this License.

However, linking a “work that uses the Library” with the Library creates an executable that is a derivative of the Library (because it contains portions of the Library), rather than a “work that uses the library”. The executable is therefore covered by this License. Section 6 states terms for distribution of such executables.

When a “work that uses the Library” uses material from a header file that is part of the Library, the object code for the work may be a derivative work of the Library even though the source code is not. Whether this is true is especially significant if the work can be linked without the Library, or if the work is itself a library. The threshold for this to be true is not precisely defined by law.

If such an object file uses only numerical parameters, data structure layouts and accessors, and small macros and small inline functions (ten lines or less in length), then the use of the object file is unrestricted, regardless of whether it is legally a derivative work. (Executables containing this object code plus portions of the Library will still fall under Section 6.)

Otherwise, if the work is a derivative of the Library, you may distribute the object code for the work under the terms of Section 6. Any executables containing that work also fall under Section 6, whether or not they are linked directly with the Library itself.

6. As an exception to the Sections above, you may also combine or link a “work that uses the Library” with the Library to produce a work containing portions of the Library, and distribute that work under terms of your choice, provided that the terms permit modification of the work for the customer’s own use and reverse engineering for debugging such modifications.

You must give prominent notice with each copy of the work that the Library is used in it and that the Library and its use are covered by this License. You must supply a copy of this License. If the work during execution displays copyright notices, you must include the copyright notice for the Library among them, as well as a reference directing the user to the copy of this License. Also, you must do one of these things:

- a) Accompany the work with the complete corresponding machine-readable source code for the Library including whatever changes were used in the work (which must be distributed under Sections 1 and 2 above); and, if the work is an executable linked with the Library, with the complete machine-readable “work that uses the Library”, as object code and/or source code, so that the user can modify the Library and then relink to produce a modified executable containing the modified Library. (It is understood that the user who changes the contents of definitions files in the Library will not necessarily be able to recompile the application to use the modified definitions.)
- b) Use a suitable shared library mechanism for linking with the Library. A suitable mechanism is one that (1) uses at run time a copy of the library already present on the user’s computer system, rather than copying library functions into the executable, and (2) will operate properly with a modified version of the library, if the user installs one, as long as the modified version is interface-compatible with the version that the work was made with.
- c) Accompany the work with a written offer, valid for at least three years, to give the same user the materials specified in Subsection 6a, above, for a charge no more than the cost of performing this distribution.
- d) If distribution of the work is made by offering access to copy from a designated place, offer equivalent access to copy the above specified materials from the same place.
- e) Verify that the user has already received a copy of these materials or that you have already sent this user a copy.

For an executable, the required form of the “work that uses the Library” must include any data and utility programs needed for reproducing the executable from it. However, as a special exception, the materials to be distributed need not include anything that is normally distributed (in either source or binary form) with the major components (compiler, kernel, and so on) of the operating system on which the executable runs, unless that component itself accompanies the executable.

It may happen that this requirement contradicts the license restrictions of other proprietary libraries that do not normally accompany the operating system. Such a contradiction means you cannot use both them and the Library together in an executable that you distribute.

- 7. You may place library facilities that are a work based on the Library side-by-side in a single library together with other library facilities not covered by this License, and distribute such a combined library, provided that the separate distribution of the work based on the Library and of the other library facilities is otherwise permitted, and provided that you do these two things:
 - a) Accompany the combined library with a copy of the same work based on the Library, uncombined with any other library facilities. This must be distributed under the terms of the Sections above.
 - b) Give prominent notice with the combined library of the fact that part of it is a work based on the Library, and explaining where to find the accompanying uncombined form of the same work.
- 8. You may not copy, modify, sublicense, link with, or distribute the Library except as expressly provided under this License. Any attempt otherwise to copy, modify, sublicense, link with, or distribute the Library is void, and will automatically terminate your rights under this License. However, parties who have received copies, or rights, from you under this License will not have their licenses terminated so long as such parties remain in full compliance.
- 9. You are not required to accept this License, since you have not signed it. However, nothing else grants you permission to modify or distribute the Library or its derivative works. These actions are prohibited by law if you do not accept this License. Therefore, by modifying or distributing the Library (or any work based on the Library), you indicate your acceptance of this License to do so, and all its terms and conditions for copying, distributing or modifying the Library or works based on it.
- 10. Each time you redistribute the Library (or any work based on the Library), the recipient automatically receives a license from the original licensor to copy, distribute, link with or modify the Library subject to these terms and conditions. You may not impose any further restrictions on the recipients’ exercise of the rights granted herein. You are not responsible for enforcing compliance by third parties with this License.

11. If, as a consequence of a court judgment or allegation of patent infringement or for any other reason (not limited to patent issues), conditions are imposed on you (whether by court order, agreement or otherwise) that contradict the conditions of this License, they do not excuse you from the conditions of this License. If you cannot distribute so as to satisfy simultaneously your obligations under this License and any other pertinent obligations, then as a consequence you may not distribute the Library at all. For example, if a patent license would not permit royalty-free redistribution of the Library by all those who receive copies directly or indirectly through you, then the only way you could satisfy both it and this License would be to refrain entirely from distribution of the Library.

If any portion of this section is held invalid or unenforceable under any particular circumstance, the balance of the section is intended to apply, and the section as a whole is intended to apply in other circumstances.

It is not the purpose of this section to induce you to infringe any patents or other property right claims or to contest validity of any such claims; this section has the sole purpose of protecting the integrity of the free software distribution system which is implemented by public license practices. Many people have made generous contributions to the wide range of software distributed through that system in reliance on consistent application of that system; it is up to the author/donor to decide if he or she is willing to distribute software through any other system and a licensee cannot impose that choice.

This section is intended to make thoroughly clear what is believed to be a consequence of the rest of this License.

12. If the distribution and/or use of the Library is restricted in certain countries either by patents or by copyrighted interfaces, the original copyright holder who places the Library under this License may add an explicit geographical distribution limitation excluding those countries, so that distribution is permitted only in or among countries not thus excluded. In such case, this License incorporates the limitation as if written in the body of this License.
13. The Free Software Foundation may publish revised and/or new versions of the Lesser General Public License from time to time. Such new versions will be similar in spirit to the present version, but may differ in detail to address new problems or concerns.

Each version is given a distinguishing version number. If the Library specifies a version number of this License which applies to it and “any later version”, you have the option of following the terms and conditions either of that version or of any later version published by the Free Software Foundation. If the Library does not specify a license version number, you may choose any version ever published by the Free Software Foundation.

14. If you wish to incorporate parts of the Library into other free programs whose distribution conditions are incompatible with these, write to the author to ask for permission. For software which is copyrighted by the Free Software Foundation, write to the Free Software Foundation; we sometimes make exceptions for this. Our decision will be guided by the two goals of preserving the free status of all derivatives of our free software and of promoting the sharing and reuse of software generally.

NO WARRANTY

15. BECAUSE THE LIBRARY IS LICENSED FREE OF CHARGE, THERE IS NO WARRANTY FOR THE LIBRARY, TO THE EXTENT PERMITTED BY APPLICABLE LAW. EXCEPT WHEN OTHERWISE STATED IN WRITING THE COPYRIGHT HOLDERS AND/OR OTHER PARTIES PROVIDE THE LIBRARY “AS IS” WITHOUT WARRANTY OF ANY KIND, EITHER EXPRESSED OR IMPLIED, INCLUDING, BUT NOT LIMITED TO, THE IMPLIED WARRANTIES OF MERCHANTABILITY AND FITNESS FOR A PARTICULAR PURPOSE. THE ENTIRE RISK AS TO THE QUALITY AND PERFORMANCE OF THE LIBRARY IS WITH YOU. SHOULD THE LIBRARY PROVE DEFECTIVE, YOU ASSUME THE COST OF ALL NECESSARY SERVICING, REPAIR OR CORRECTION.
16. IN NO EVENT UNLESS REQUIRED BY APPLICABLE LAW OR AGREED TO IN WRITING WILL ANY COPYRIGHT HOLDER, OR ANY OTHER PARTY WHO MAY MODIFY AND/OR REDISTRIBUTE THE LIBRARY AS PERMITTED ABOVE, BE LIABLE TO YOU FOR DAMAGES, INCLUDING ANY GENERAL, SPECIAL, INCIDENTAL OR CONSEQUENTIAL DAMAGES ARISING OUT OF THE USE OR INABILITY TO USE THE LIBRARY (INCLUDING BUT NOT LIMITED TO LOSS OF DATA OR DATA BEING RENDERED INACCURATE OR LOSSES SUSTAINED BY YOU OR THIRD PARTIES OR A FAILURE OF THE LIBRARY TO

OPERATE WITH ANY OTHER SOFTWARE), EVEN IF SUCH HOLDER OR OTHER PARTY HAS BEEN ADVISED OF THE POSSIBILITY OF SUCH DAMAGES.

END OF TERMS AND CONDITIONS

How to Apply These Terms to Your New Libraries

If you develop a new library, and you want it to be of the greatest possible use to the public, we recommend making it free software that everyone can redistribute and change. You can do so by permitting redistribution under these terms (or, alternatively, under the terms of the ordinary General Public License).

To apply these terms, attach the following notices to the library. It is safest to attach them to the start of each source file to most effectively convey the exclusion of warranty; and each file should have at least the “copyright” line and a pointer to where the full notice is found.

<one line to give the library’s name and an idea of what it does.>

Copyright (C) <year> <name of author>

This library is free software; you can redistribute it and/or modify it under the terms of the GNU Lesser General Public License as published by the Free Software Foundation; either version 2.1 of the License, or (at your option) any later version.

This library is distributed in the hope that it will be useful, but WITHOUT ANY WARRANTY; without even the implied warranty of MERCHANTABILITY or FITNESS FOR A PARTICULAR PURPOSE. See the GNU Lesser General Public License for more details.

You should have received a copy of the GNU Lesser General Public License along with this library; if not, write to the Free Software Foundation, Inc., 59 Temple Place, Suite 330, Boston, MA 02111-1307 USA

Also add information on how to contact you by electronic and paper mail.

You should also get your employer (if you work as a programmer) or your school, if any, to sign a “copyright disclaimer” for the library, if necessary. Here is a sample; alter the names:

Yoyodyne, Inc., hereby disclaims all copyright interest in the library `Frob' (a library for tweaking knobs) written by James Random Hacker.

signature of Ty Coon, 1 April 1990

Ty Coon, President of Vice

That’s all there is to it!

This product includes software portmap to which the license below applies.

Please note that we cannot respond to inquiries regarding the content of the source code.

Copyright (c) 1990 The Regents of the University of California.

All rights reserved.

Redistribution and use in source and binary forms, with or without modification, are permitted provided that the following conditions are met:

1. Redistributions of source code must retain the above copyright notice, this list of conditions and the following disclaimer.
2. Redistributions in binary form must reproduce the above copyright notice, this list of conditions and the following disclaimer in the documentation and/or other materials provided with the distribution.

3. All advertising materials mentioning features or use of this software must display the following acknowledgement:
This product includes software developed by the University of California, Berkeley and its contributors.
4. Neither the name of the University nor the names of its contributors may be used to endorse or promote products derived from this software without specific prior written permission.

THIS SOFTWARE IS PROVIDED BY THE REGENTS AND CONTRIBUTORS “AS IS” AND ANY EXPRESS OR IMPLIED WARRANTIES, INCLUDING, BUT NOT LIMITED TO, THE IMPLIED WARRANTIES OF MERCHANTABILITY AND FITNESS FOR A PARTICULAR PURPOSE ARE DISCLAIMED. IN NO EVENT SHALL THE REGENTS OR CONTRIBUTORS BE LIABLE FOR ANY DIRECT, INDIRECT, INCIDENTAL, SPECIAL, EXEMPLARY, OR CONSEQUENTIAL DAMAGES (INCLUDING, BUT NOT LIMITED TO, PROCUREMENT OF SUBSTITUTE GOODS OR SERVICES; LOSS OF USE, DATA, OR PROFITS; OR BUSINESS INTERRUPTION) HOWEVER CAUSED AND ON ANY THEORY OF LIABILITY, WHETHER IN CONTRACT, STRICT LIABILITY, OR TORT (INCLUDING NEGLIGENCE OR OTHERWISE) ARISING IN ANY WAY OUT OF THE USE OF THIS SOFTWARE, EVEN IF ADVISED OF THE POSSIBILITY OF SUCH DAMAGE.

This product includes software trace to which the license below applies.
Please note that we cannot respond to inquiries regarding the content of the source code.

Copyright (c) 1991, 1992 Paul Kranenburg <pk@cs.few.eur.nl>
Copyright (c) 1993 Branko Lankester <branko@hacktic.nl>
Copyright (c) 1993 Ulrich Pegelow <pegelow@moorea.uni-muenster.de>
Copyright (c) 1995, 1996 Michael Elizabeth Chastain <mec@duracef.shout.net>
Copyright (c) 1993, 1994, 1995, 1996 Rick Sladkey <jrs@world.std.com>
Copyright (C) 1998-2001 Wichert Akkerman <wakkerma@deephackmode.org>
All rights reserved.

Redistribution and use in source and binary forms, with or without modification, are permitted provided that the following conditions are met:

1. Redistributions of source code must retain the above copyright notice, this list of conditions and the following disclaimer.
2. Redistributions in binary form must reproduce the above copyright notice, this list of conditions and the following disclaimer in the documentation and/or other materials provided with the distribution.
3. The name of the author may not be used to endorse or promote products derived from this software without specific prior written permission.

THIS SOFTWARE IS PROVIDED BY THE AUTHOR “AS IS” AND ANY EXPRESS OR IMPLIED WARRANTIES, INCLUDING, BUT NOT LIMITED TO, THE IMPLIED WARRANTIES OF MERCHANTABILITY AND FITNESS FOR A PARTICULAR PURPOSE ARE DISCLAIMED. IN NO EVENT SHALL THE AUTHOR BE LIABLE FOR ANY DIRECT, INDIRECT, INCIDENTAL, SPECIAL, EXEMPLARY, OR CONSEQUENTIAL DAMAGES (INCLUDING, BUT NOT LIMITED TO, PROCUREMENT OF SUBSTITUTE GOODS OR SERVICES; LOSS OF USE, DATA, OR PROFITS; OR BUSINESS INTERRUPTION) HOWEVER CAUSED AND ON ANY THEORY OF LIABILITY, WHETHER IN CONTRACT, STRICT LIABILITY, OR TORT (INCLUDING NEGLIGENCE OR OTHERWISE) ARISING IN ANY WAY OUT OF THE USE OF THIS SOFTWARE, EVEN IF ADVISED OF THE POSSIBILITY OF SUCH DAMAGE.

This product includes software libxml2 to which the license below applies.
Please note that we cannot respond to inquiries regarding the content of the source code.

Copyright (C) 1998-2003 Daniel Veillard. All Rights Reserved.

Permission is hereby granted, free of charge, to any person obtaining a copy of this software and associated documentation files (the “Software”), to deal in the Software without restriction, including without limitation the rights to use, copy,

modify, merge, publish, distribute, sublicense, and/or sell copies of the Software, and to permit persons to whom the Software is furnished to do so, subject to the following conditions:

The above copyright notice and this permission notice shall be included in all copies or substantial portions of the Software.

THE SOFTWARE IS PROVIDED “AS IS”, WITHOUT WARRANTY OF ANY KIND, EXPRESS OR IMPLIED, INCLUDING BUT NOT LIMITED TO THE WARRANTIES OF MERCHANTABILITY, FITNESS FOR A PARTICULAR PURPOSE AND NONINFRINGEMENT. IN NO EVENT SHALL THE DANIEL VEILLARD BE LIABLE FOR ANY CLAIM, DAMAGES OR OTHER LIABILITY, WHETHER IN AN ACTION OF CONTRACT, TORT OR OTHERWISE, ARISING FROM, OUT OF OR IN CONNECTION WITH THE SOFTWARE OR THE USE OR OTHER DEALINGS IN THE SOFTWARE.

Except as contained in this notice, the name of Daniel Veillard shall not be used in advertising or otherwise to promote the sale, use or other dealings in this Software without prior written authorization from him.

This product includes software developed by the OpenSSL Project for use in the OpenSSL Toolkit.
(<http://www.openssl.org/>).

Please note that we cannot respond to inquiries regarding the content of the source code.

OpenSSL License

Copyright (c) 1998-2011 The OpenSSL Project. All rights reserved.

Redistribution and use in source and binary forms, with or without modification, are permitted provided that the following conditions are met:

1. Redistributions of source code must retain the above copyright notice, this list of conditions and the following disclaimer.
2. Redistributions in binary form must reproduce the above copyright notice, this list of conditions and the following disclaimer in the documentation and/or other materials provided with the distribution.
3. All advertising materials mentioning features or use of this software must display the following acknowledgment: “This product includes software developed by the OpenSSL Project for use in the OpenSSL Toolkit. (<http://www.openssl.org/>)”
4. The names “OpenSSL Toolkit” and “OpenSSL Project” must not be used to endorse or promote products derived from this software without prior written permission. For written permission, please contact openssl-core@openssl.org.
5. Products derived from this software may not be called “OpenSSL” nor may “OpenSSL” appear in their names without prior written permission of the OpenSSL Project.
6. Redistributions of any form whatsoever must retain the following acknowledgment: “This product includes software developed by the OpenSSL Project for use in the OpenSSL Toolkit (<http://www.openssl.org/>)”

THIS SOFTWARE IS PROVIDED BY THE OpenSSL PROJECT “AS IS” AND ANY EXPRESSED OR IMPLIED WARRANTIES, INCLUDING, BUT NOT LIMITED TO, THE IMPLIED WARRANTIES OF MERCHANTABILITY AND FITNESS FOR A PARTICULAR PURPOSE ARE DISCLAIMED. IN NO EVENT SHALL THE OpenSSL PROJECT OR ITS CONTRIBUTORS BE LIABLE FOR ANY DIRECT, INDIRECT, INCIDENTAL, SPECIAL, EXEMPLARY, OR CONSEQUENTIAL DAMAGES (INCLUDING, BUT NOT LIMITED TO, PROCUREMENT OF SUBSTITUTE GOODS OR SERVICES; LOSS OF USE, DATA, OR PROFITS; OR BUSINESS INTERRUPTION) HOWEVER CAUSED AND ON ANY THEORY OF LIABILITY, WHETHER IN CONTRACT, STRICT LIABILITY, OR TORT (INCLUDING NEGLIGENCE OR OTHERWISE) ARISING IN ANY WAY OUT OF THE USE OF THIS SOFTWARE, EVEN IF ADVISED OF THE POSSIBILITY OF SUCH DAMAGE.

This product includes cryptographic software written by Eric Young (ey@cryptsoft.com). This product includes software written by Tim Hudson (tjh@cryptsoft.com).

Original SSLeay License

Copyright (C) 1995-1998 Eric Young (eay@cryptsoft.com)

All rights reserved.

This package is an SSL implementation written by Eric Young (eay@cryptsoft.com).

The implementation was written so as to conform with Netscapes SSL.

This library is free for commercial and non-commercial use as long as the following conditions are aheared to. The following conditions apply to all code found in this distribution, be it the RC4, RSA, lhash, DES, etc., code; not just the SSL code. The SSL documentation included with this distribution is covered by the same copyright terms except that the holder is Tim Hudson (tjh@cryptsoft.com).

Copyright remains Eric Young's, and as such any Copyright notices in the code are not to be removed.

If this package is used in a product, Eric Young should be given attribution as the author of the parts of the library used. This can be in the form of a textual message at program startup or in documentation (online or textual) provided with the package.

Redistribution and use in source and binary forms, with or without modification, are permitted provided that the following conditions are met:

1. Redistributions of source code must retain the copyright notice, this list of conditions and the following disclaimer.
2. Redistributions in binary form must reproduce the above copyright notice, this list of conditions and the following disclaimer in the documentation and/or other materials provided with the distribution.
3. All advertising materials mentioning features or use of this software must display the following acknowledgement:
"This product includes cryptographic software written by Eric Young (eay@cryptsoft.com)"
The word 'cryptographic' can be left out if the rouines from the library being used are not cryptographic related :-).
4. If you include any Windows specific code (or a derivative thereof) from the apps directory (application code) you must include an acknowledgement:
"This product includes software written by Tim Hudson (tjh@cryptsoft.com)"

THIS SOFTWARE IS PROVIDED BY ERIC YOUNG "AS IS" AND ANY EXPRESS OR IMPLIED WARRANTIES, INCLUDING, BUT NOT LIMITED TO, THE IMPLIED WARRANTIES OF MERCHANTABILITY AND FITNESS FOR A PARTICULAR PURPOSE ARE DISCLAIMED. IN NO EVENT SHALL THE AUTHOR OR CONTRIBUTORS BE LIABLE FOR ANY DIRECT, INDIRECT, INCIDENTAL, SPECIAL, EXEMPLARY, OR CONSEQUENTIAL DAMAGES (INCLUDING, BUT NOT LIMITED TO, PROCUREMENT OF SUBSTITUTE GOODS OR SERVICES; LOSS OF USE, DATA, OR PROFITS; OR BUSINESS INTERRUPTION) HOWEVER CAUSED AND ON ANY THEORY OF LIABILITY, WHETHER IN CONTRACT, STRICT LIABILITY, OR TORT (INCLUDING NEGLIGENCE OR OTHERWISE) ARISING IN ANY WAY OUT OF THE USE OF THIS SOFTWARE, EVEN IF ADVISED OF THE POSSIBILITY OF SUCH DAMAGE.

The licence and distribution terms for any publically available version or derivative of this code cannot be changed. i.e. this code cannot simply be copied and put under another distribution licence [including the GNU Public Licence.]

This product includes software dhcpcclient to which the license below applies.

Please note that we cannot respond to inquiries regarding the content of the source code.

Copyright © 2004-2011 by Internet Systems Consortium, Inc. ("ISC")

Copyright © 1995-2003 by Internet Software Consortium

Permission to use, copy, modify, and/or distribute this software for any purpose with or without fee is hereby granted, provided that the above copyright notice and this permission notice appear in all copies.

THE SOFTWARE IS PROVIDED “AS IS” AND ISC DISCLAIMS ALL WARRANTIES WITH REGARD TO THIS SOFTWARE INCLUDING ALL IMPLIED WARRANTIES OF MERCHANTABILITY AND FITNESS. IN NO EVENT SHALL ISC BE LIABLE FOR ANY SPECIAL, DIRECT, INDIRECT, OR CONSEQUENTIAL DAMAGES OR ANY DAMAGES WHATSOEVER RESULTING FROM LOSS OF USE, DATA OR PROFITS, WHETHER IN AN ACTION OF CONTRACT, NEGLIGENCE OR OTHER TORTIOUS ACTION, ARISING OUT OF OR IN CONNECTION WITH THE USE OR PERFORMANCE OF THIS SOFTWARE.

This product includes software openssh to which the license below applies.
Please note that we cannot respond to inquiries regarding the content of the source code.

The licences which components of this software fall under are as follows. First, we will summarize and say that all components are under a BSD licence, or a licence more free than that.

OpenSSH contains no GPL code.

1)
Copyright (c) 1995 Tatu Ylonen <ylo@cs.hut.fi>, Espoo, Finland
All rights reserved

As far as I am concerned, the code I have written for this software can be used freely for any purpose. Any derived versions of this software must be clearly marked as such, and if the derived work is incompatible with the protocol description in the RFC file, it must be called by a name other than “ssh” or “Secure Shell” .

[Tatu continues]

However, I am not implying to give any licenses to any patents or copyrights held by third parties, and the software includes parts that are not under my direct control. As far as I know, all included source code is used in accordance with the relevant license agreements and can be used freely for any purpose (the GNU license being the most restrictive); see below for details.

[However, none of that term is relevant at this point in time. All of these restrictively licenced software components which he talks about have been removed from OpenSSH, i.e.,

- RSA is no longer included, found in the OpenSSL library
- IDEA is no longer included, its use is deprecated
- DES is now external, in the OpenSSL library
- GMP is no longer used, and instead we call BN code from OpenSSL
- Zlib is now external, in a library
- The make-ssh-known-hosts script is no longer included
- TSS has been removed
- MD5 is now external, in the OpenSSL library
- RC4 support has been replaced with ARC4 support from OpenSSL
- Blowfish is now external, in the OpenSSL library

[The licence continues]

Note that any information and cryptographic algorithms used in this software are publicly available on the Internet and at any major bookstore, scientific library, and patent office worldwide. More information can be found e.g. at “<http://www.cs.hut.fi/crypto>”.

The legal status of this program is some combination of all these permissions and restrictions. Use only at your own responsibility.

You will be responsible for any legal consequences yourself; I am not making any claims whether possessing or using this is legal or not in your country, and I am not taking any responsibility on your behalf.

NO WARRANTY

BECAUSE THE PROGRAM IS LICENSED FREE OF CHARGE, THERE IS NO WARRANTY FOR THE PROGRAM, TO THE EXTENT PERMITTED BY APPLICABLE LAW. EXCEPT WHEN OTHERWISE STATED IN WRITING THE COPYRIGHT HOLDERS AND/OR OTHER PARTIES PROVIDE THE PROGRAM "AS IS" WITHOUT WARRANTY OF ANY KIND, EITHER EXPRESSED OR IMPLIED, INCLUDING, BUT NOT LIMITED TO, THE IMPLIED WARRANTIES OF MERCHANTABILITY AND FITNESS FOR A PARTICULAR PURPOSE. THE ENTIRE RISK AS TO THE QUALITY AND PERFORMANCE OF THE PROGRAM IS WITH YOU. SHOULD THE PROGRAM PROVE DEFECTIVE, YOU ASSUME THE COST OF ALL NECESSARY SERVICING, REPAIR OR CORRECTION.

IN NO EVENT UNLESS REQUIRED BY APPLICABLE LAW OR AGREED TO IN WRITING WILL ANY COPYRIGHT HOLDER, OR ANY OTHER PARTY WHO MAY MODIFY AND/OR REDISTRIBUTE THE PROGRAM AS PERMITTED ABOVE, BE LIABLE TO YOU FOR DAMAGES, INCLUDING ANY GENERAL, SPECIAL, INCIDENTAL OR CONSEQUENTIAL DAMAGES ARISING OUT OF THE USE OR INABILITY TO USE THE PROGRAM (INCLUDING BUT NOT LIMITED TO LOSS OF DATA OR DATA BEING RENDERED INACCURATE OR LOSSES SUSTAINED BY YOU OR THIRD PARTIES OR A FAILURE OF THE PROGRAM TO OPERATE WITH ANY OTHER PROGRAMS), EVEN IF SUCH HOLDER OR OTHER PARTY HAS BEEN ADVISED OF THE POSSIBILITY OF SUCH DAMAGES.

- 2) The 32-bit CRC compensation attack detector in deattack.c was contributed by CORE SDI S.A. under a BSD-style license.

Cryptographic attack detector for ssh - source code

Copyright (c) 1998 CORE SDI S.A., Buenos Aires, Argentina.

All rights reserved. Redistribution and use in source and binary forms, with or without modification, are permitted provided that this copyright notice is retained.

THIS SOFTWARE IS PROVIDED "AS IS" AND ANY EXPRESS OR IMPLIED WARRANTIES ARE DISCLAIMED. IN NO EVENT SHALL CORE SDI S.A. BE LIABLE FOR ANY DIRECT, INDIRECT, INCIDENTAL, SPECIAL, EXEMPLARY OR CONSEQUENTIAL DAMAGES RESULTING FROM THE USE OR MISUSE OF THIS SOFTWARE.

Ariel Futoransky <futo@core-sdi.com>
<<http://www.core-sdi.com>>

- 3) ssh-keyscan was contributed by David Mazieres under a BSD-style license.

Copyright 1995, 1996 by David Mazieres <dm@lcs.mit.edu>.

Modification and redistribution in source and binary forms is permitted provided that due credit is given to the author and the OpenBSD project by leaving this copyright notice intact.

- 4) The Rijndael implementation by Vincent Rijmen, Antoon Bosselaers and Paulo Barreto is in the public domain and distributed with the following license:

@version 3.0 (December 2000)

Optimised ANSI C code for the Rijndael cipher (now AES)

@author Vincent Rijmen <vincent.rijmen@esat.kuleuven.ac.be>
@author Antoon Bosselaers <antoon.bosselaers@esat.kuleuven.ac.be>
@author Paulo Barreto <paulo.barreto@terra.com.br>

This code is hereby placed in the public domain.

THIS SOFTWARE IS PROVIDED BY THE AUTHORS “AS IS” AND ANY EXPRESS OR IMPLIED WARRANTIES, INCLUDING, BUT NOT LIMITED TO, THE IMPLIED WARRANTIES OF MERCHANTABILITY AND FITNESS FOR A PARTICULAR PURPOSE ARE DISCLAIMED. IN NO EVENT SHALL THE AUTHORS OR CONTRIBUTORS BE LIABLE FOR ANY DIRECT, INDIRECT, INCIDENTAL, SPECIAL, EXEMPLARY, OR CONSEQUENTIAL DAMAGES (INCLUDING, BUT NOT LIMITED TO, PROCUREMENT OF SUBSTITUTE GOODS OR SERVICES; LOSS OF USE, DATA, OR PROFITS; OR BUSINESS INTERRUPTION) HOWEVER CAUSED AND ON ANY THEORY OF LIABILITY, WHETHER IN CONTRACT, STRICT LIABILITY, OR TORT (INCLUDING NEGLIGENCE OR OTHERWISE) ARISING IN ANY WAY OUT OF THE USE OF THIS SOFTWARE, EVEN IF ADVISED OF THE POSSIBILITY OF SUCH DAMAGE.

- 5) One component of the ssh source code is under a 3-clause BSD license, held by the University of California, since we pulled these parts from original Berkeley code.

Copyright (c) 1983, 1990, 1992, 1993, 1995
The Regents of the University of California. All rights reserved.

Redistribution and use in source and binary forms, with or without modification, are permitted provided that the following conditions are met:

1. Redistributions of source code must retain the above copyright notice, this list of conditions and the following disclaimer.
2. Redistributions in binary form must reproduce the above copyright notice, this list of conditions and the following disclaimer in the documentation and/or other materials provided with the distribution.
3. Neither the name of the University nor the names of its contributors may be used to endorse or promote products derived from this software without specific prior written permission.

THIS SOFTWARE IS PROVIDED BY THE REGENTS AND CONTRIBUTORS “AS IS” AND ANY EXPRESS OR IMPLIED WARRANTIES, INCLUDING, BUT NOT LIMITED TO, THE IMPLIED WARRANTIES OF MERCHANTABILITY AND FITNESS FOR A PARTICULAR PURPOSE ARE DISCLAIMED. IN NO EVENT SHALL THE REGENTS OR CONTRIBUTORS BE LIABLE FOR ANY DIRECT, INDIRECT, INCIDENTAL, SPECIAL, EXEMPLARY, OR CONSEQUENTIAL DAMAGES (INCLUDING, BUT NOT LIMITED TO, PROCUREMENT OF SUBSTITUTE GOODS OR SERVICES; LOSS OF USE, DATA, OR PROFITS; OR BUSINESS INTERRUPTION) HOWEVER CAUSED AND ON ANY THEORY OF LIABILITY, WHETHER IN CONTRACT, STRICT LIABILITY, OR TORT (INCLUDING NEGLIGENCE OR OTHERWISE) ARISING IN ANY WAY OUT OF THE USE OF THIS SOFTWARE, EVEN IF ADVISED OF THE POSSIBILITY OF SUCH DAMAGE.

- 6) Remaining components of the software are provided under a standard 2-term BSD licence with the following names as copyright holders:

Markus Friedl
Theo de Raadt
Niels Provos
Dug Song
Aaron Campbell
Damien Miller
Kevin Steves
Daniel Kouril
Wesley Griffin
Per Allansson
Nils Nordman
Simon Wilkinson

Portable OpenSSH additionally includes code from the following copyright holders, also under the 2-term BSD license:

Ben Lindstrom
Tim Rice
Andre Lucas
Chris Adams
Corinna Vinschen
Cray Inc.
Denis Parker
Gert Doering
Jakob Schlyter
Jason Downs
Juha Yrjölä
Michael Stone
Networks Associates Technology, Inc.
Solar Designer
Todd C. Miller
Wayne Schroeder
William Jones
Darren Tucker
Sun Microsystems
The SCO Group
Daniel Walsh

Redistribution and use in source and binary forms, with or without modification, are permitted provided that the following conditions are met:

1. Redistributions of source code must retain the above copyright notice, this list of conditions and the following disclaimer.
2. Redistributions in binary form must reproduce the above copyright notice, this list of conditions and the following disclaimer in the documentation and/or other materials provided with the distribution.

THIS SOFTWARE IS PROVIDED BY THE AUTHOR "AS IS" AND ANY EXPRESS OR IMPLIED WARRANTIES, INCLUDING, BUT NOT LIMITED TO, THE IMPLIED WARRANTIES OF MERCHANTABILITY AND FITNESS FOR A PARTICULAR PURPOSE ARE DISCLAIMED. IN NO EVENT SHALL THE AUTHOR BE LIABLE FOR ANY DIRECT, INDIRECT, INCIDENTAL, SPECIAL, EXEMPLARY, OR CONSEQUENTIAL DAMAGES (INCLUDING, BUT NOT LIMITED TO, PROCUREMENT OF SUBSTITUTE GOODS OR SERVICES; LOSS OF USE, DATA, OR PROFITS; OR BUSINESS INTERRUPTION) HOWEVER CAUSED AND ON ANY THEORY OF LIABILITY, WHETHER IN CONTRACT, STRICT LIABILITY, OR TORT (INCLUDING NEGLIGENCE OR OTHERWISE) ARISING IN ANY WAY OUT OF THE USE OF THIS SOFTWARE, EVEN IF ADVISED OF THE POSSIBILITY OF SUCH DAMAGE.

8) Portable OpenSSH contains the following additional licenses:

a) md5crypt.c, md5crypt.h

“THE BEER-WARE LICENSE” (Revision 42):

<phk@login.dknet.dk> wrote this file. As long as you retain this notice you can do whatever you want with this stuff. If we meet some day, and you think this stuff is worth it, you can buy me a beer in return. Poul-Henning Kamp

b) snprintf replacement

Copyright Patrick Powell 1995

This code is based on code written by Patrick Powell (papowell@astart.com) It may be used for any purpose as long as this notice remains intact on all source code distributions

c) Compatibility code (openbsd-compat)

Apart from the previously mentioned licenses, various pieces of code in the openbsd-compat/ subdirectory are licensed as follows:

Some code is licensed under a 3-term BSD license, to the following copyright holders:

Todd C. Miller
Theo de Raadt
Damien Miller
Eric P. Allman
The Regents of the University of California
Constantin S. Svintsoff

Redistribution and use in source and binary forms, with or without modification, are permitted provided that the following conditions are met:

- 1.Redistributions of source code must retain the above copyright notice, this list of conditions and the following disclaimer.
- 2.Redistributions in binary form must reproduce the above copyright notice, this list of conditions and the following disclaimer in the documentation and/or other materials provided with the distribution.
- 3.Neither the name of the University nor the names of its contributors may be used to endorse or promote products derived from this software without specific prior written permission.

THIS SOFTWARE IS PROVIDED BY THE REGENTS AND CONTRIBUTORS “AS IS” AND ANY EXPRESS OR IMPLIED WARRANTIES, INCLUDING, BUT NOT LIMITED TO, THE IMPLIED WARRANTIES OF MERCHANTABILITY AND FITNESS FOR A PARTICULAR PURPOSE ARE DISCLAIMED. IN NO EVENT SHALL THE REGENTS OR CONTRIBUTORS BE LIABLE FOR ANY DIRECT, INDIRECT, INCIDENTAL, SPECIAL, EXEMPLARY, OR CONSEQUENTIAL DAMAGES (INCLUDING, BUT NOT LIMITED TO, PROCUREMENT OF SUBSTITUTE GOODS OR SERVICES; LOSS OF USE, DATA, OR PROFITS; OR BUSINESS INTERRUPTION) HOWEVER CAUSED AND ON ANY THEORY OF LIABILITY, WHETHER IN CONTRACT, STRICT LIABILITY, OR TORT (INCLUDING NEGLIGENCE OR OTHERWISE) ARISING IN ANY WAY OUT OF THE USE OF THIS SOFTWARE, EVEN IF ADVISED OF THE POSSIBILITY OF SUCH DAMAGE.

Some code is licensed under an ISC-style license, to the following copyright holders:

Internet Software Consortium.
Todd C. Miller
Reyk Floeter
Chad Mynhier

Permission to use, copy, modify, and distribute this software for any purpose with or without fee is hereby granted, provided that the above copyright notice and this permission notice appear in all copies.

THE SOFTWARE IS PROVIDED “AS IS” AND TODD C. MILLER DISCLAIMS ALL WARRANTIES WITH REGARD TO THIS SOFTWARE INCLUDING ALL IMPLIED WARRANTIES OF MERCHANTABILITY AND FITNESS. IN NO EVENT SHALL TODD C. MILLER BE LIABLE FOR ANY SPECIAL, DIRECT, INDIRECT, OR CONSEQUENTIAL DAMAGES OR ANY DAMAGES WHATSOEVER RESULTING FROM LOSS OF USE, DATA OR PROFITS, WHETHER IN AN ACTION OF CONTRACT, NEGLIGENCE OR OTHER TORTIOUS ACTION, ARISING OUT OF OR IN CONNECTION WITH THE USE OR PERFORMANCE OF THIS SOFTWARE.

Some code is licensed under a MIT-style license to the following copyright holders:

Free Software Foundation, Inc.

Permission is hereby granted, free of charge, to any person obtaining a copy of this software and associated documentation files (the “Software”), to deal in the Software without restriction, including without limitation the rights to use, copy, modify, merge, publish, distribute, distribute with modifications, sublicense, and/or sell copies of the Software, and to permit persons to whom the Software is furnished to do so, subject to the following conditions:

The above copyright notice and this permission notice shall be included in all copies or substantial portions of the Software.

THE SOFTWARE IS PROVIDED “AS IS”, WITHOUT WARRANTY OF ANY KIND, EXPRESS OR IMPLIED, INCLUDING BUT NOT LIMITED TO THE WARRANTIES OF MERCHANTABILITY, FITNESS FOR A PARTICULAR PURPOSE AND NONINFRINGEMENT. IN NO EVENT SHALL THE ABOVE COPYRIGHT HOLDERS BE LIABLE FOR ANY CLAIM, DAMAGES OR OTHER LIABILITY, WHETHER IN AN ACTION OF CONTRACT, TORT OR OTHERWISE, ARISING FROM, OUT OF OR IN CONNECTION WITH THE SOFTWARE OR THE USE OR OTHER DEALINGS IN THE SOFTWARE.

Except as contained in this notice, the name(s) of the above copyright holders shall not be used in advertising or otherwise to promote the sale, use or other dealings in this Software without prior written authorization.

This product includes software libpng to which the license below applies.
Please note that we cannot respond to inquiries regarding the content of the source code.

libpng versions 1.2.6, August 15, 2004, through 1.5.2, March 31, 2011, are Copyright (c) 2004, 2006-2011 Glenn Randers-Pehrson, and are distributed according to the same disclaimer and license as libpng-1.2.5 with the following individual added to the list of Contributing Authors

Cosmin Truta

libpng versions 1.0.7, July 1, 2000, through 1.2.5 - October 3, 2002, are Copyright (c) 2000-2002 Glenn Randers-Pehrson, and are distributed according to the same disclaimer and license as libpng-1.0.6 with the following individuals added to the list of Contributing Authors

Simon-Pierre Cadieux
Eric S. Raymond
Gilles Vollant

and with the following additions to the disclaimer:

There is no warranty against interference with your enjoyment of the library or against infringement. There is no warranty that our efforts or the library will fulfill any of your particular purposes or needs. This library is provided with all faults, and the entire risk of satisfactory quality, performance, accuracy, and effort is with the user.

libpng versions 0.97, January 1998, through 1.0.6, March 20, 2000, are Copyright (c) 1998, 1999 Glenn Randers-Pehrson, and are distributed according to the same disclaimer and license as libpng-0.96, with the following individuals added to the list of Contributing Authors:

Tom Lane
Glenn Randers-Pehrson
Willem van Schaik

libpng versions 0.89, June 1996, through 0.96, May 1997, are Copyright (c) 1996, 1997 Andreas Dilger Distributed according to the same disclaimer and license as libpng-0.88, with the following individuals added to the list of Contributing Authors:

John Bowler
Kevin Bracey
Sam Bushell
Magnus Holmgren
Greg Roelofs
Tom Tanner

libpng versions 0.5, May 1995, through 0.88, January 1996, are Copyright (c) 1995, 1996 Guy Eric Schalnat, Group 42, Inc.

For the purposes of this copyright and license, “Contributing Authors” is defined as the following set of individuals:

Andreas Dilger
Dave Martindale
Guy Eric Schalnat
Paul Schmidt
Tim Wegner

The PNG Reference Library is supplied “AS IS”. The Contributing Authors and Group 42, Inc. disclaim all warranties, expressed or implied, including, without limitation, the warranties of merchantability and of fitness for any purpose. The Contributing Authors and Group 42, Inc. assume no liability for direct, indirect, incidental, special, exemplary, or consequential damages, which may result from the use of the PNG Reference Library, even if advised of the possibility of such damage.

Permission is hereby granted to use, copy, modify, and distribute this source code, or portions hereof, for any purpose, without fee, subject to the following restrictions:

1. The origin of this source code must not be misrepresented.
2. Altered versions must be plainly marked as such and must not be misrepresented as being the original source.
3. This Copyright notice may not be removed or altered from any source or altered source distribution.

The Contributing Authors and Group 42, Inc. specifically permit, without fee, and encourage the use of this source code as a component to supporting the PNG file format in commercial products. If you use this source code in a product, acknowledgment is not required but would be appreciated.

A “png_get_copyright” function is available, for convenient use in “about” boxes and the like:

```
printf("%s",png_get_copyright(NULL));
```

Also, the PNG logo (in PNG format, of course) is supplied in the files “pngbar.png” and “pngbar.jpg” (88x31) and “pngnow.png” (98x31).

Libpng is OSI Certified Open Source Software. OSI Certified Open Source is a certification mark of the Open Source Initiative.

Glenn Randers-Pehrson
glennrp at users.sourceforge.net

This product includes software libcurl to which the license below applies.
Please note that we cannot respond to inquiries regarding the content of the source code.

Copyright (c) 1996 - 2010, Daniel Stenberg, <daniel@haxx.se>.

All rights reserved.

Permission to use, copy, modify, and distribute this software for any purpose with or without fee is hereby granted, provided that the above copyright notice and this permission notice appear in all copies.

THE SOFTWARE IS PROVIDED “AS IS”, WITHOUT WARRANTY OF ANY KIND, EXPRESS OR IMPLIED, INCLUDING BUT NOT LIMITED TO THE WARRANTIES OF MERCHANTABILITY, FITNESS FOR A PARTICULAR PURPOSE AND NON-INFRINGEMENT OF THIRD PARTY RIGHTS. IN NO EVENT SHALL THE AUTHORS OR COPYRIGHT HOLDERS BE LIABLE FOR ANY CLAIM, DAMAGES OR OTHER LIABILITY, WHETHER IN AN ACTION OF CONTRACT, TORT OR OTHERWISE, ARISING FROM, OUT OF OR IN CONNECTION WITH THE SOFTWARE OR THE USE OR OTHER DEALINGS IN THE SOFTWARE.

Except as contained in this notice, the name of a copyright holder shall not be used in advertising or otherwise to promote the sale, use or other dealings in this Software without prior written authorization of the copyright holder

This product includes software libexpat to which the license below applies.
Please note that we cannot respond to inquiries regarding the content of the source code.

Copyright (c) 1998, 1999, 2000 Thai Open Source Software Center Ltd and Clark Cooper
Copyright (c) 2001, 2002, 2003, 2004, 2005, 2006 Expat maintainers.

Permission is hereby granted, free of charge, to any person obtaining a copy of this software and associated documentation files (the Software), to deal in the Software without restriction, including without limitation the rights to use, copy, modify, merge, publish, distribute, sublicense, and/or sell copies of the Software, and to permit persons to whom the Software is furnished to do so, subject to the following conditions:

The above copyright notice and this permission notice shall be included in all copies or substantial portions of the Software.

THE SOFTWARE IS PROVIDED “AS IS”, WITHOUT WARRANTY OF ANY KIND, EXPRESS OR IMPLIED, INCLUDING BUT NOT LIMITED TO THE WARRANTIES OF MERCHANTABILITY, FITNESS FOR A PARTICULAR PURPOSE AND NON-INFRINGEMENT.
IN NO EVENT SHALL THE AUTHORS OR COPYRIGHT HOLDERS BE LIABLE FOR ANY CLAIM, DAMAGES OR OTHER LIABILITY, WHETHER IN AN ACTION OF CONTRACT, TORT OR OTHERWISE, ARISING FROM, OUT OF OR IN CONNECTION WITH THE SOFTWARE OR THE USE OR OTHER DEALINGS IN THE SOFTWARE.

This product includes software zlib to which the license below applies.
Please note that we cannot respond to inquiries regarding the content of the source code.

(C) 1995-2004 Jean-loup Gailly and Mark Adler

This software is provided ‘as-is’, without any express or implied warranty. In no event will the authors be held liable for any damages arising from the use of this software.

Permission is granted to anyone to use this software for any purpose, including commercial applications, and to alter it and redistribute it freely, subject to the following restrictions:

1. The origin of this software must not be misrepresented; you must not claim that you wrote the original software. If you use this software in a product, an acknowledgment in the product documentation would be appreciated but is not required.
2. Altered source versions must be plainly marked as such, and must not be misrepresented as being the original software.
3. This notice may not be removed or altered from any source distribution.

Jean-loup Gailly
jloup@gzip.org

Mark Adler
madler@alumni.caltech.edu

This product includes software lighttpd to which the license below applies.
Please note that we cannot respond to inquiries regarding the content of the source code.

Copyright (c) 2004, Jan Kneschke, incremental
All rights reserved.

Redistribution and use in source and binary forms, with or without modification, are permitted provided that the following conditions are met:

- Redistributions of source code must retain the above copyright notice, this list of conditions and the following disclaimer.
- Redistributions in binary form must reproduce the above copyright notice, this list of conditions and the following disclaimer in the documentation and/or other materials provided with the distribution.
- Neither the name of the 'incremental' nor the names of its contributors may be used to endorse or promote products derived from this software without specific prior written permission.

THIS SOFTWARE IS PROVIDED BY THE COPYRIGHT HOLDERS AND CONTRIBUTORS "AS IS" AND ANY EXPRESS OR IMPLIED WARRANTIES, INCLUDING, BUT NOT LIMITED TO, THE IMPLIED WARRANTIES OF MERCHANTABILITY AND FITNESS FOR A PARTICULAR PURPOSE ARE DISCLAIMED. IN NO EVENT SHALL THE COPYRIGHT OWNER OR CONTRIBUTORS BE LIABLE FOR ANY DIRECT, INDIRECT, INCIDENTAL, SPECIAL, EXEMPLARY, OR CONSEQUENTIAL DAMAGES (INCLUDING, BUT NOT LIMITED TO, PROCUREMENT OF SUBSTITUTE GOODS OR SERVICES; LOSS OF USE, DATA, OR PROFITS; OR BUSINESS INTERRUPTION) HOWEVER CAUSED AND ON ANY THEORY OF LIABILITY, WHETHER IN CONTRACT, STRICT LIABILITY, OR TORT (INCLUDING NEGLIGENCE OR OTHERWISE) ARISING IN ANY WAY OUT OF THE USE OF THIS SOFTWARE, EVEN IF ADVISED OF THE POSSIBILITY OF SUCH DAMAGE.

This product includes software file to which the license below applies.
Please note that we cannot respond to inquiries regarding the content of the source code.

Copyright (c) Ian F. Darwin 1986, 1987, 1989, 1990, 1991, 1992, 1994, 1995.
Software written by Ian F. Darwin and others;
maintained 1994- Christos Zoulas.

This software is not subject to any export provision of the United States Department of Commerce, and may be exported to any country or planet.

Redistribution and use in source and binary forms, with or without modification, are permitted provided that the following conditions are met:

1. Redistributions of source code must retain the above copyright notice immediately at the beginning of the file, without modification, this list of conditions, and the following disclaimer.
2. Redistributions in binary form must reproduce the above copyright notice, this list of conditions and the following disclaimer in the documentation and/or other materials provided with the distribution.

THIS SOFTWARE IS PROVIDED BY THE AUTHOR AND CONTRIBUTORS "AS IS" AND ANY EXPRESS OR IMPLIED WARRANTIES, INCLUDING, BUT NOT LIMITED TO, THE IMPLIED WARRANTIES OF MERCHANTABILITY AND FITNESS FOR A PARTICULAR PURPOSE ARE DISCLAIMED. IN NO EVENT SHALL THE AUTHOR OR CONTRIBUTORS BE LIABLE FOR ANY DIRECT, INDIRECT, INCIDENTAL, SPECIAL, EXEMPLARY, OR CONSEQUENTIAL DAMAGES (INCLUDING, BUT NOT LIMITED TO, PROCUREMENT OF SUBSTITUTE GOODS OR SERVICES; LOSS OF USE, DATA, OR PROFITS; OR BUSINESS INTERRUPTION) HOWEVER CAUSED AND ON ANY THEORY OF LIABILITY, WHETHER IN CONTRACT, STRICT LIABILITY, OR TORT (INCLUDING NEGLIGENCE OR OTHERWISE) ARISING IN ANY WAY OUT OF THE USE OF THIS SOFTWARE, EVEN IF ADVISED OF THE POSSIBILITY OF SUCH DAMAGE.

This product includes software freetype to which the license below applies.
Please note that we cannot respond to inquiries regarding the content of the source code.

The FreeType Project LICENSE

2006-Jan-27

Copyright 1996-2002, 2006 by
David Turner, Robert Wilhelm, and Werner Lemberg

Introduction

The FreeType Project is distributed in several archive packages; some of them may contain, in addition to the FreeType font engine, various tools and contributions which rely on, or relate to, the FreeType Project.

This license applies to all files found in such packages, and which do not fall under their own explicit license. The license affects thus the FreeType font engine, the test programs, documentation and makefiles, at the very least.

This license was inspired by the BSD, Artistic, and IJG (Independent JPEG Group) licenses, which all encourage inclusion and use of free software in commercial and freeware products alike. As a consequence, its main points are that:

- We don't promise that this software works. However, we will be interested in any kind of bug reports. ('as is' distribution)
- You can use this software for whatever you want, in parts or full form, without having to pay us. ('royalty-free' usage)
- You may not pretend that you wrote this software. If you use it, or only parts of it, in a program, you must acknowledge somewhere in your documentation that you have used the FreeType code. ('credits')

We specifically permit and encourage the inclusion of this software, with or without modifications, in commercial products.

We disclaim all warranties covering The FreeType Project and assume no liability related to The FreeType Project.

Finally, many people asked us for a preferred form for a credit/disclaimer to use in compliance with this license. We thus encourage you to use the following text:

Portions of this software are copyright (C) <year> The FreeType Project (www.freetype.org). All rights reserved.

Please replace <year> with the value from the FreeType version you actually use.

Legal Terms

0. Definitions

Throughout this license, the terms 'package', 'FreeType Project', and 'FreeType archive' refer to the set of files originally distributed by the authors (David Turner, Robert Wilhelm, and Werner Lemberg) as the 'FreeType Project', be they named as alpha, beta or final release.

'You' refers to the licensee, or person using the project, where 'using' is a generic term including compiling the project's source code as well as linking it to form a 'program' or 'executable'.
This program is referred to as 'a program using the FreeType engine'.

This license applies to all files distributed in the original FreeType Project, including all source code, binaries and documentation, unless otherwise stated in the file in its original, unmodified form as distributed in the original archive. If you are unsure whether or not a particular file is covered by this license, you must contact us to verify this.

The FreeType Project is copyright (C) 1996-2000 by David Turner, Robert Wilhelm, and Werner Lemberg. All rights reserved except as specified below.

1. No Warranty

THE FREETYPE PROJECT IS PROVIDED 'AS IS' WITHOUT WARRANTY OF ANY KIND, EITHER EXPRESS OR IMPLIED, INCLUDING, BUT NOT LIMITED TO, WARRANTIES OF MERCHANTABILITY AND FITNESS FOR A PARTICULAR PURPOSE. IN NO EVENT WILL ANY OF THE AUTHORS OR COPYRIGHT HOLDERS BE LIABLE FOR ANY DAMAGES CAUSED BY THE USE OR THE INABILITY TO USE, OF THE FREETYPE PROJECT.

2. Redistribution

This license grants a worldwide, royalty-free, perpetual and irrevocable right and license to use, execute, perform, compile, display, copy, create derivative works of, distribute and sublicense the FreeType Project (in both source and object code forms) and derivative works thereof for any purpose; and to authorize others to exercise some or all of the rights granted herein, subject to the following conditions:

- Redistribution of source code must retain this license file ('FTL.TXT') unaltered; any additions, deletions or changes to the original files must be clearly indicated in accompanying documentation. The copyright notices of the unaltered, original files must be preserved in all copies of source files.
- Redistribution in binary form must provide a disclaimer that states that the software is based in part of the work of the FreeType Team, in the distribution documentation. We also encourage you to put an URL to the FreeType web page in your documentation, though this isn't mandatory.

These conditions apply to any software derived from or based on the FreeType Project, not just the unmodified files. If you use our work, you must acknowledge us. However, no fee need be paid to us.

3. Advertising

Neither the FreeType authors and contributors nor you shall use the name of the other for commercial, advertising, or promotional purposes without specific prior written permission.

We suggest, but do not require, that you use one or more of the following phrases to refer to this software in your documentation or advertising materials: 'FreeType Project', 'FreeType Engine', 'FreeType library', or 'FreeType Distribution'.

As you have not signed this license, you are not required to accept it. However, as the FreeType Project is copyrighted material, only this license, or another one contracted with the authors, grants you the right to use, distribute, and modify it.

Therefore, by using, distributing, or modifying the FreeType Project, you indicate that you understand and accept all the terms of this license.

4. Contacts

There are two mailing lists related to FreeType:

- freetype@nongnu.org

Discusses general use and applications of FreeType, as well as future and wanted additions to the library and distribution.

If you are looking for support, start in this list if you haven't found anything to help you in the documentation.

- freetype-devel@nongnu.org

Discusses bugs, as well as engine internals, design issues, specific licenses, porting, etc.

Our home page can be found at

<http://www.freetype.org>

This product includes software usagi-tool to which the license below applies.
Please note that we cannot respond to inquiries regarding the content of the source code.

Copyright (C) 2007 USAGI/WIDE Project.
All rights reserved.

Redistribution and use in source and binary forms, with or without modification, are permitted provided that the following conditions are met:

1. Redistributions of source code must retain the above copyright notice, this list of conditions and the following disclaimer.
2. Redistributions in binary form must reproduce the above copyright notice, this list of conditions and the following disclaimer in the documentation and/or other materials provided with the distribution.
3. Neither the name of the project nor the names of its contributors may be used to endorse or promote products derived from this software without specific prior written permission.

THIS SOFTWARE IS PROVIDED BY THE PROJECT AND CONTRIBUTORS “AS IS” AND ANY EXPRESS OR IMPLIED WARRANTIES, INCLUDING, BUT NOT LIMITED TO, THE IMPLIED WARRANTIES OF MERCHANTABILITY AND FITNESS FOR A PARTICULAR PURPOSE ARE DISCLAIMED. IN NO EVENT SHALL THE PROJECT OR CONTRIBUTORS BE LIABLE FOR ANY DIRECT, INDIRECT, INCIDENTAL, SPECIAL, EXEMPLARY, OR CONSEQUENTIAL DAMAGES (INCLUDING, BUT NOT LIMITED TO, PROCUREMENT OF SUBSTITUTE GOODS OR SERVICES; LOSS OF USE, DATA, OR PROFITS; OR BUSINESS INTERRUPTION) HOWEVER CAUSED AND ON ANY THEORY OF LIABILITY, WHETHER IN CONTRACT, STRICT LIABILITY, OR TORT (INCLUDING NEGLIGENCE OR OTHERWISE) ARISING IN ANY WAY OUT OF THE USE OF THIS SOFTWARE, EVEN IF ADVISED OF THE POSSIBILITY OF SUCH DAMAGE.

This product includes software Net BSD to which the license below applies.
Please note that we cannot respond to inquiries regarding the content of the source code.

Copyright (c) 1994-2004 The NetBSD Foundation, Inc. All rights reserved.

Redistribution and use in source and binary forms, with or without modification, are permitted provided that the following conditions are met:

1. Redistributions of source code must retain the above copyright notice, this list of conditions and the following disclaimer.
2. Redistributions in binary form must reproduce the above copyright notice, this list of conditions and the following disclaimer in the documentation and/or other materials provided with the distribution.
3. All advertising materials mentioning features or use of this software must display the following acknowledgement:
This product includes software developed by the NetBSD Foundation, Inc. and its contributors.
4. Neither the name of The NetBSD Foundation nor the names of its contributors may be used to endorse or promote products derived from this software without specific prior written permission.

THIS SOFTWARE IS PROVIDED BY THE REGENTS AND CONTRIBUTORS “AS IS” AND ANY EXPRESS OR IMPLIED WARRANTIES, INCLUDING, BUT NOT LIMITED TO, THE IMPLIED WARRANTIES OF MERCHANTABILITY AND FITNESS FOR A PARTICULAR PURPOSE ARE DISCLAIMED. IN NO EVENT SHALL THE REGENTS OR CONTRIBUTORS BE LIABLE FOR ANY DIRECT, INDIRECT, INCIDENTAL, SPECIAL, EXEMPLARY, OR CONSEQUENTIAL DAMAGES (INCLUDING, BUT NOT LIMITED TO, PROCUREMENT OF SUBSTITUTE GOODS OR SERVICES; LOSS OF USE, DATA, OR PROFITS; OR BUSINESS INTERRUPTION) HOWEVER CAUSED AND ON ANY THEORY OF LIABILITY, WHETHER IN CONTRACT, STRICT LIABILITY, OR TORT (INCLUDING NEGLIGENCE OR OTHERWISE) ARISING IN ANY WAY OUT OF THE USE OF THIS SOFTWARE, EVEN IF ADVISED OF THE POSSIBILITY OF SUCH DAMAGE.

The following notices are required to satisfy the license terms of the software that we have mentioned in this document:

- This product includes software developed by Adam Glass.
- This product includes software developed by Bill Paul.
- This product includes software developed by Brini.
- This product includes software developed by Causality Limited.
- This product includes software developed by Charles M. Hannum.
- This product includes software developed by Christian E. Hopps.
- This product includes software developed by Christopher G. Demetriou.
- This product includes software developed by Christopher G. Demetriou for the NetBSD Project.
- This product includes software developed by Christos Zoulas.
- This product includes software developed by Gardner Buchanan.
- This product includes software developed by Gordon W. Ross.
- This product includes software developed by Manuel Bouyer.
- This product includes software developed by Mark Brinicombe.
- This product includes software developed by Rolf Grossmann.
- This product includes software developed by TooLs GmbH.
- This product includes software developed by the NetBSD Foundation, Inc. and its contributors.
- This product includes software developed by the RiscBSD team.
- This product includes software developed by the University of California, Berkeley and its contributors.
- This product includes software developed by the University of California, Lawrence Berkeley Laboratory and its contributors.
- This product includes software developed by the University of California, Lawrence Berkeley Laboratory.
- This product includes software developed for the NetBSD Project by Wasabi Systems, Inc.
- This product includes software developed for the NetBSD Project by Matthias Drochner.

This product includes software to which the license below applies.
Please note that we cannot respond to inquiries regarding the content of the source code.

Copyright (c) 1998-2004, 2006 Free Software Foundation, Inc.

Permission is hereby granted, free of charge, to any person obtaining a copy of this software and associated documentation files (the “Software”), to deal in the Software without restriction, including without limitation the rights to use, copy, modify, merge, publish, distribute, distribute with modifications, sublicense, and/or sell copies of the Software, and to permit persons to whom the Software is furnished to do so, subject to the following conditions:

The above copyright notice and this permission notice shall be included in all copies or substantial portions of the Software.

THE SOFTWARE IS PROVIDED “AS IS”, WITHOUT WARRANTY OF ANY KIND, EXPRESS OR IMPLIED, INCLUDING BUT NOT LIMITED TO THE WARRANTIES OF MERCHANTABILITY, FITNESS FOR A PARTICULAR PURPOSE AND NONINFRINGEMENT.
IN NO EVENT SHALL THE ABOVE COPYRIGHT HOLDERS BE LIABLE FOR ANY CLAIM, DAMAGES OR OTHER LIABILITY, WHETHER IN AN ACTION OF CONTRACT, TORT OR OTHERWISE, ARISING FROM, OUT OF OR IN CONNECTION WITH THE SOFTWARE OR THE USE OR OTHER DEALINGS IN THE SOFTWARE.

Except as contained in this notice, the name(s) of the above copyright holders shall not be used in advertising or otherwise to promote the sale, use or other dealings in this Software without prior written authorization.

This product includes software libjpeg to which the license below applies.
Please note that we cannot respond to inquiries regarding the content of the source code.

This software is based in part on the work of the Independent JPEG Group.

This product includes software PHP5.3.5 to which the license below applies.
Please note that we cannot respond to inquiries regarding the content of the source code.

The PHP License, version 3.01
Copyright (c) 1999 - 2012 The PHP Group. All rights reserved.

Redistribution and use in source and binary forms, with or without modification, is permitted provided that the following conditions are met:

1. Redistributions of source code must retain the above copyright notice, this list of conditions and the following disclaimer.
2. Redistributions in binary form must reproduce the above copyright notice, this list of conditions and the following disclaimer in the documentation and/or other materials provided with the distribution.
3. The name “PHP” must not be used to endorse or promote products derived from this software without prior written permission. For written permission, please contact group@php.net.
4. Products derived from this software may not be called “PHP”, nor may “PHP” appear in their name, without prior written permission from group@php.net. You may indicate that your software works in conjunction with PHP by saying “Foo for PHP” instead of calling it “PHP Foo” or “phpfoo”
5. The PHP Group may publish revised and/or new versions of the license from time to time. Each version will be given a distinguishing version number.
Once covered code has been published under a particular version of the license, you may always continue to use it under the terms of that version. You may also choose to use such covered code under the terms of any subsequent version of the license published by the PHP Group. No one other than the PHP Group has the right to modify the terms applicable to covered code created under this License.
6. Redistributions of any form whatsoever must retain the following acknowledgment:
“This product includes PHP software, freely available from
<<http://www.php.net/software/>>”.

THIS SOFTWARE IS PROVIDED BY THE PHP DEVELOPMENT TEAM “AS IS” AND ANY EXPRESSED OR IMPLIED WARRANTIES, INCLUDING, BUT NOT LIMITED TO, THE IMPLIED WARRANTIES OF MERCHANTABILITY AND FITNESS FOR A PARTICULAR PURPOSE ARE DISCLAIMED. IN NO EVENT SHALL THE PHP DEVELOPMENT TEAM OR ITS CONTRIBUTORS BE LIABLE FOR ANY DIRECT, INDIRECT, INCIDENTAL, SPECIAL, EXEMPLARY, OR CONSEQUENTIAL DAMAGES (INCLUDING, BUT NOT LIMITED TO, PROCUREMENT OF SUBSTITUTE GOODS OR SERVICES; LOSS OF USE, DATA, OR PROFITS; OR BUSINESS INTERRUPTION) HOWEVER CAUSED AND ON ANY THEORY OF LIABILITY, WHETHER IN CONTRACT, STRICT LIABILITY, OR TORT (INCLUDING NEGLIGENCE OR OTHERWISE) ARISING IN ANY WAY OUT OF THE USE OF THIS SOFTWARE, EVEN IF ADVISED OF THE POSSIBILITY OF SUCH DAMAGE.

This software consists of voluntary contributions made by many individuals on behalf of the PHP Group.

The PHP Group can be contacted via Email at group@php.net.

For more information on the PHP Group and the PHP project, please see <<http://www.php.net>>.

PHP includes the Zend Engine, freely available at <<http://www.zend.com>>.

The material contained in this manual consists of information that is the property of Sony Corporation and is intended solely for use by the purchasers of the equipment described in this manual.

Sony Corporation expressly prohibits the duplication of any portion of this manual or the use thereof for any purpose other than the operation or maintenance of the equipment described in this manual without the express written permission of Sony Corporation.

Sony Corporation